

THK



NEW

Wide Type Roller Guide with Caged Technology

Ultra-High Rigidity, Heavy Load

Low Friction

Long Service Life, Long-Term

Maintenance-Free Operation

SRW

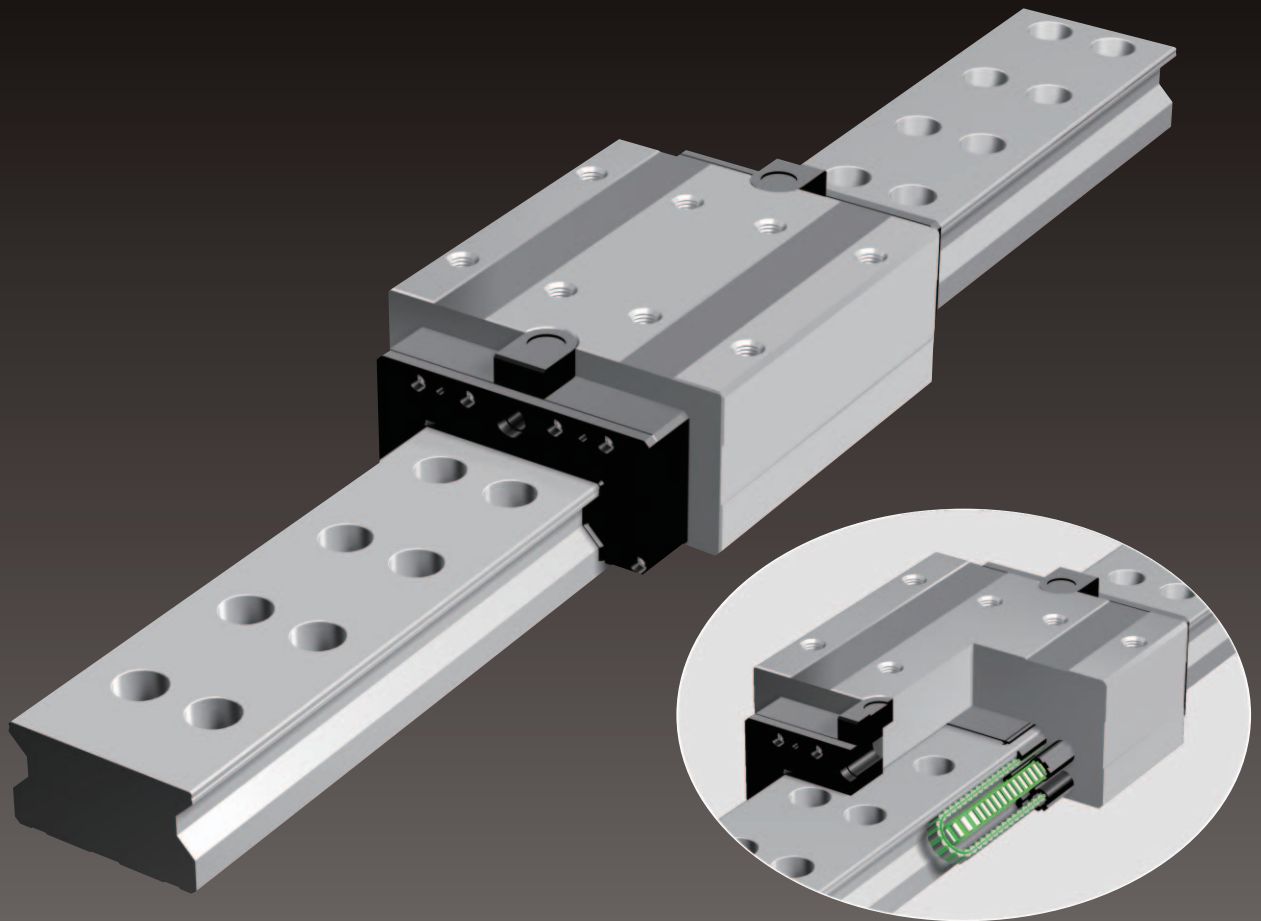

THK CO., LTD.

TOKYO, JAPAN

This catalog uses recycled paper.

CATALOG No.312-1EW

Roller Guide with Caged Technology Model SRW **SRW**

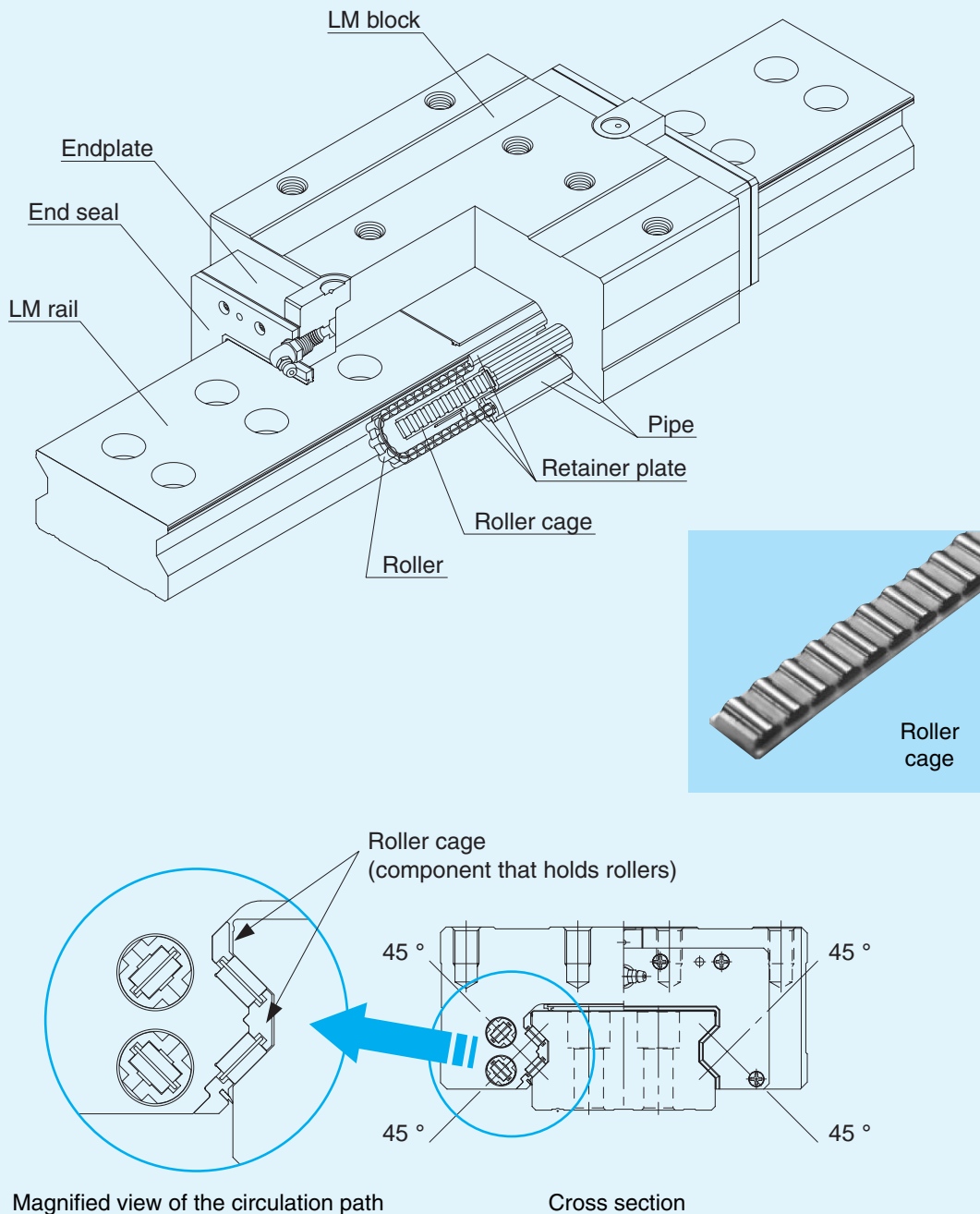

Fig. 1 Structure of Model SRW

Based on Roller Guide with Caged Technology model SRG, this model has a wider rail and two rows of LM rail mounting holes to achieve high mounting strength and mounting stability. Use of the roller cage allows low friction and smooth motion. Thus, model SRW is an ultra-high rigidity Roller Guide that achieves long-term maintenance-free operation.

Features of Model SRW

● Super-ultra-high Rigidity

Since it has a wide rail and can be secured on the table using the two rows of mounting bolts, the mounting strength is significantly increased. In addition, since the crosswise raceway distance is large (wide), model SRW is structurally strong against a moment load (MC moment) in the rolling direction.

Model SRW uses rollers that show little elastic deformation as its rolling elements, and the overall length of each roller is 1.5 times greater than the diameter, thus to increase the rigidity.

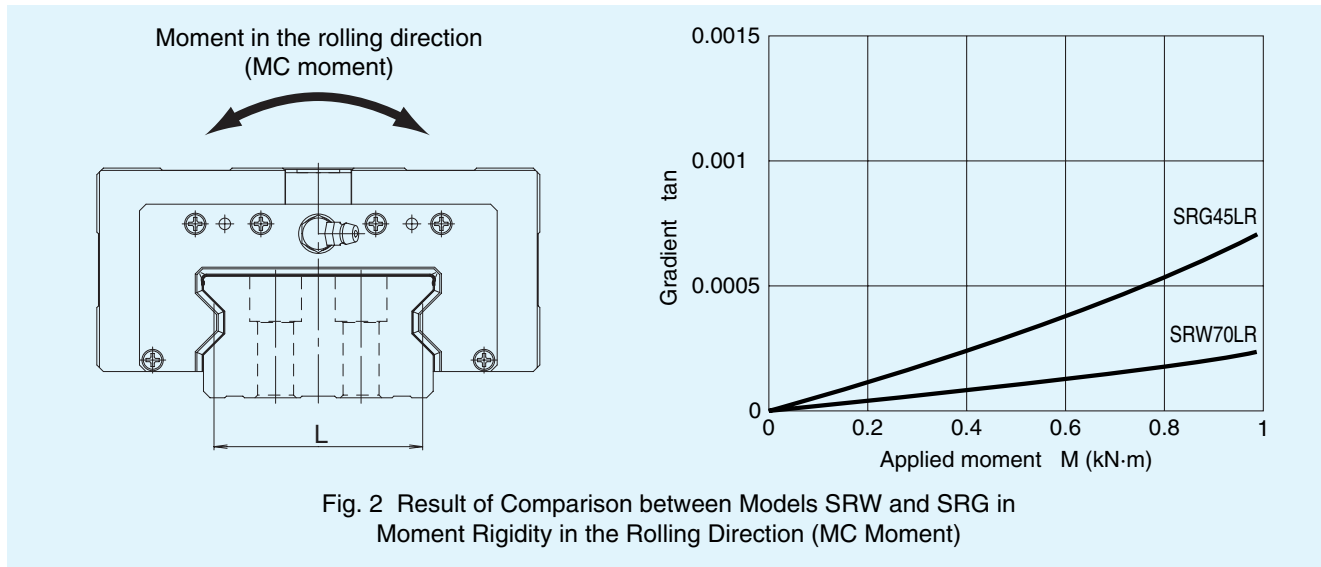

Fig. 2 Result of Comparison between Models SRW and SRG in Moment Rigidity in the Rolling Direction (MC Moment)

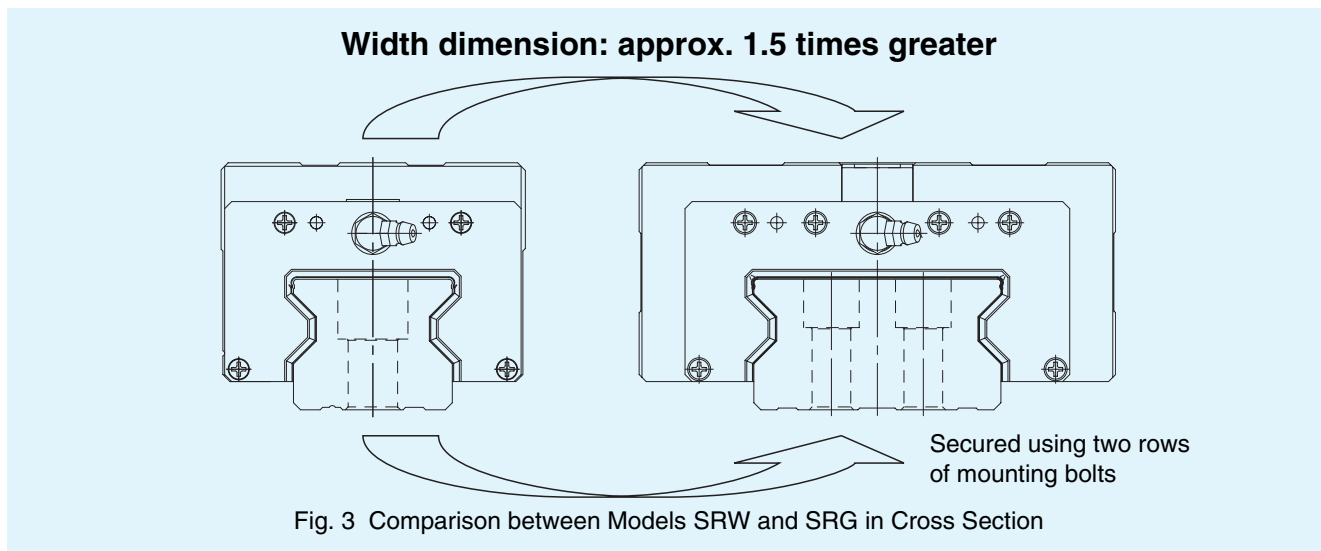

Fig. 3 Comparison between Models SRW and SRG in Cross Section

● Smoothness Achieved through Skewing Prevention

The roller cage allows rollers to form an evenly spaced line while circulating, thus preventing the rollers from skewing as the block enters a loaded area. As a result, fluctuation of the rolling resistance is minimized, and stable, smooth motion is achieved.

● Long-term Maintenance-free Operation

Use of the roller cage eliminates friction between rollers and enables the lubricant to be retained in grease pockets formed between adjacent rollers. As the balls circulate, the grease pocket serves to provide the required amount of lubricant to the contact curvature of the spacer and the roller, thus to achieve long-term maintenance-free operation.

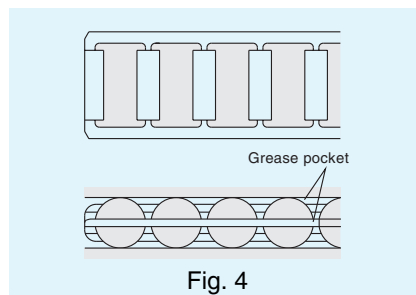

Fig. 4

Options

If foreign matter or dust enters model SRW, it may lead to abnormal wear of the product, damage of the raceway or rollers or damage of the circulation structure, which may shorten the service life.

Therefore, where entry of foreign matter or dust is predictable, it is necessary to take an effective dust-prevention measure that meets the service environment.

THK offers a wide range of options in order to respond to extensive service environments.

When desiring to use one of the options, indicate that the option is required when placing an order for the product.

Dust Prevention Accessories

Seals

End seal

Attached to both ends of the LM block, the end seal prevents foreign matter and water adhering to the top and side faces of the LM rail from entering the LM block. This accessory is available as standard as a means to prevent the lubricant inside the LM block from leaking.

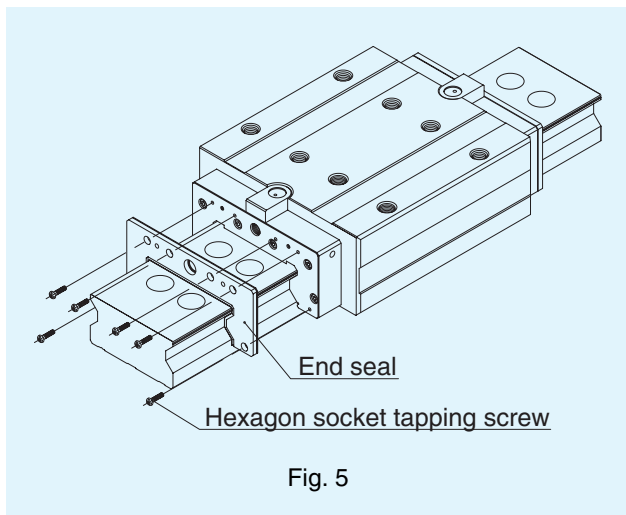

Side seal

The side seal blocks foreign matter and water from entering the LM block from its lower side face. It is also effective in preventing the lubricant from leaking from the bottom of the LM block.

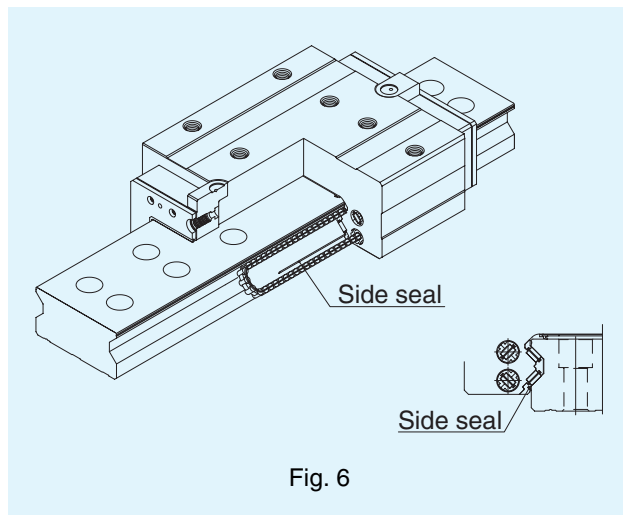

Double seals

The double-seal assembly is an option designed to achieve increased sealability. Even if the first end seal fails to trap part of foreign matter, the second seal traps it, thus to prevent it from entering the LM block.

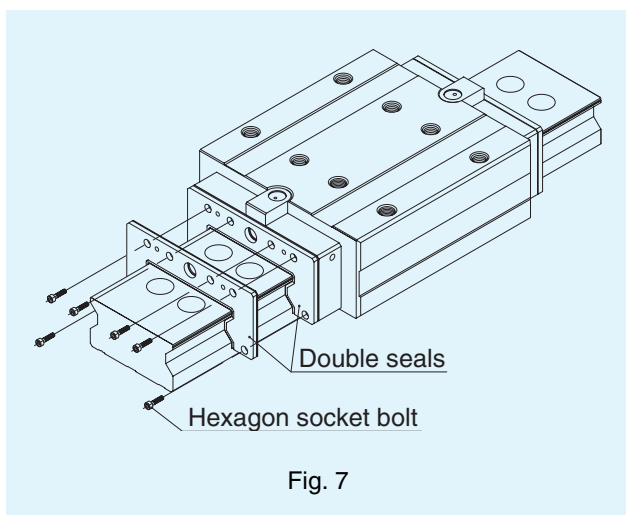

Inner seal

If a small quantity of foreign matter or dust scraping through the end seal enters the LM block, the inner seal prevents the foreign matter from reaching the roller raceway and retains the lubricant on the roller raceway.

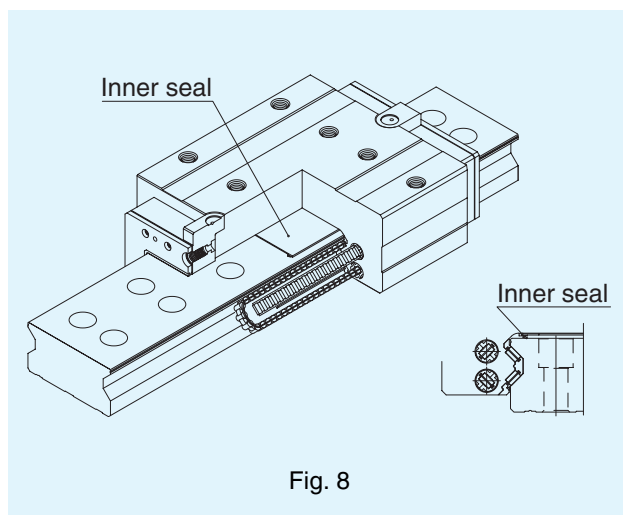

● Scrapers

■ Metal Scraper (Non-contact)

The metal scraper is used to remove relatively large foreign matter or solid foreign matter, such as cutting chips, spatter and sand dust, which adheres to the LM rail.

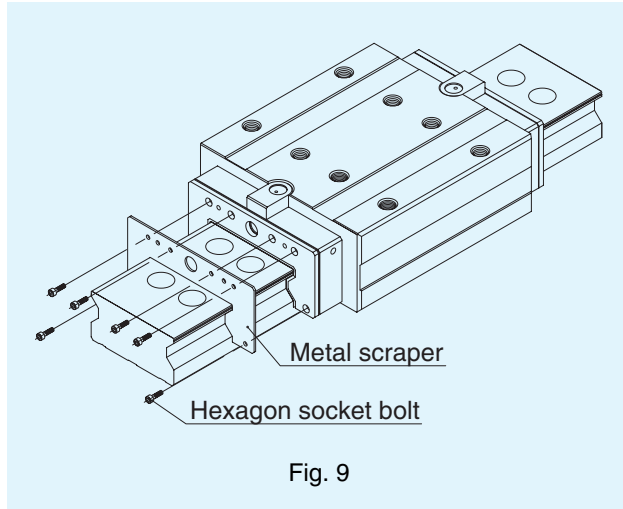

Fig. 9

■ LaCS (Laminated Contact Scraper)

Unlike the metal scraper, LaCS removes foreign matter through surface contact with the LM rail. As a result, it demonstrates a high dust-prevention effect against minute foreign matter, which was difficult to remove with the metal scraper.

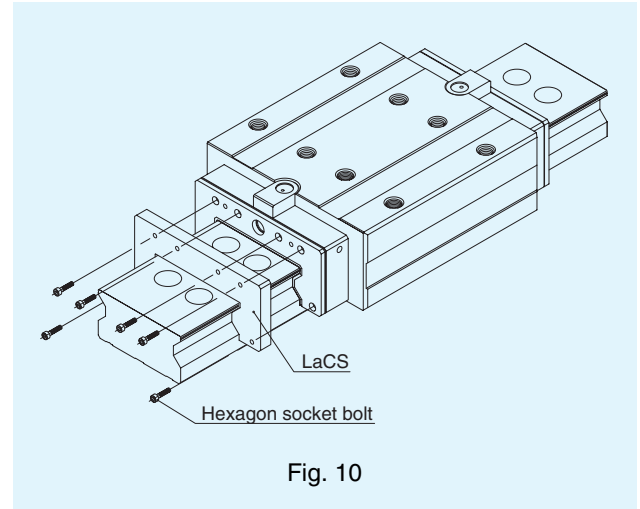

Fig. 10

● Symbols of Dust Prevention Accessories

If a dust prevention accessory is required, indicate the corresponding symbol shown in table 1. The overall LM block length increases according to the type of the dust prevention accessory. Refer to table 2 below.

Table 1 Symbols of Dust Prevention Accessories for Model SRW

Symbol	Dust prevention accessory
UU	With end seal (both ends)
SS	With end seal + side seal + inner seal (standard)
DD	With double seals + side seal + inner seal
ZZ	With end seal + side seal + inner seal + metal scraper
KK	With double seals + side seal + inner seal + metal scraper
SSHH	With end seal + side seal + inner seal + LaCS
DDHH	With double seals + side seal + inner seal + LaCS
ZZHH	With end seal + side seal + inner seal + metal scraper + LaCS
KKHH	With double seals + side seal + inner seal + metal scraper + LaCS

Table 2 Overall LM Block Length of Model SRW with a Dust Prevention Accessory Attached

Unit: mm

Model No.	No option attached	UU	SS	DD	ZZ	KK	SSHH	DDHH	ZZHH	KKHH
SRW 70	180.8	190	190	199.2	197.2	206.4	217	226.2	220.2	229.4
SRW 85	225.8	235	235	244.2	242.2	251.4	262	271.2	265.2	274.4
SRW 100	291.8	303	303	314.2	311.4	322.6	335.4	346.6	338.6	349.8

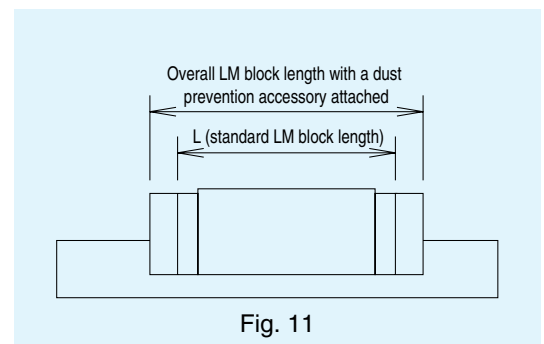

Fig. 11

● Seal Resistance

For the maximum seal resistance per LM block of model SRW attached with seals (symbol SS), see the corresponding value provided in table 3.

Table 3 Seal Resistance

Unit: N

Model No.	Resistance
SRW 70	32
SRW 85	37
SRW 100	43

Note: The values in the table each indicate the maximum the seal resistance value per LM block containing grease.

●Dedicated Cap C for LM Rail Mounting Holes

If any of the LM rail mounting holes of an LM Guide is filled with cutting chips or foreign matter, they may enter the LM block structure. Entrance of such foreign matter can be prevented by covering each LM rail mounting hole with the dedicated cap so that the top of the mounting holes are on the same level as the LM rail top face.

Since the dedicated cap C for LM rail mounting holes uses a special synthetic resin with high oil resistance and high wear resistance, it is highly durable. Those types of the dedicated cap C for hexagon socket bolts M10 to M14 are standard-stock items; when placing an order for any of these types, specify the corresponding cap number indicated in the dimensional table.

To attach the dedicated cap to the mounting hole, place a flat metal piece like the one shown in Fig. 13 on the cap and gradually hammer in the cap until it is on the same level as the top face of the LM rail.

Table 4 Major Dimensions of the Dedicated Cap C

Supported model No.	Cap C model No.	Bolt used	Major dimensions (mm)	
			D	H
SRW 70	C10	M10	18.0	3.7
SRW 85	C12	M12	20.5	4.7
SRW 100	C14	M14	23.5	5.7

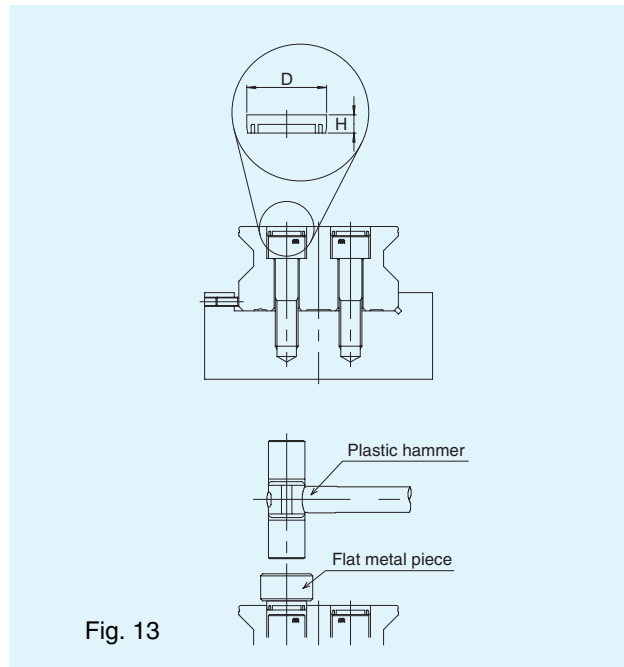

●Dedicated Bellows JSRW for Model SRW

The table below shows the dimensions of dedicated bellows JSRW for model SRW. Specify the corresponding model number of the desired bellows from the table.

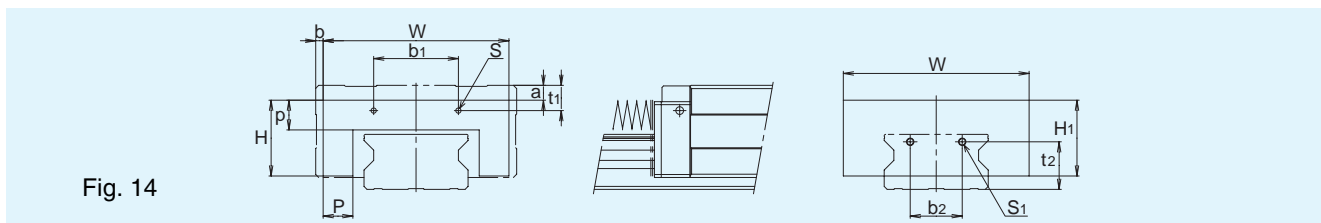

Table 5 Dimensions of the Bellows

Bellows model No.	Major dimensions (mm)										Screw size S	Mounting bolt S ₁	a	b	A ($\frac{L_{max}}{L_{min}}$)	Supported model No.
	W	H	H ₁	P	p	b ₁	t ₁	b ₂	t ₂							
JSRW 70	125	51	51	20	20	57	17	35	32	M3	M5 x 4L	10	5	7	SRW 70	
JSRW 85	138	57	57	20	20	68	20	42	36	M3	M5 x 4L	13	13.5	7	SRW 85	
JSRW 100	169	75.5	75.5	28.5	25	83	19	50	46	M4	M6 x 5L	13	15.5	9	SRW 100	

Note 1: For lubrication when using the dedicated bellows, contact THK.

Note 2: When desiring to use the dedicated bellows other than in horizontal mount (i.e., vertical, wall and inverted mount), or when desiring a heat-resistant type of bellows, contact THK.

Model number coding

JSRW70-60/420

1

2

1 Model number

2 Bellows dimensions (length when compressed / length when extended)

QZ™ Lubricator

QZ Lubricator is a lubrication system that feeds the right amount of lubricant to the right place by contacting a highly dense fiber net to the raceway.

■Allows a Significant Increase of the Maintenance Interval

With ordinary grease lubrication, a minimal amount of oil is lost as the system travels. QZ Lubricator supplements lost oil to drastically extend the maintenance interval.

■An Environmentally Friendly Lubrication System

An environmentally friendly lubrication system that does not contaminate the surrounding area since it feeds the right amount of lubricant to the ball raceway through a highly dense fiber net.

■Allows Oil Setting According to the Intended Use

QZ Lubricator allows the setting of oil according to the service conditions. Contact THK for details.

Table 6 Symbols of Dust Prevention Accessories including QZ Lubricator for Model SRW

Symbol	Dust prevention accessory with QZ Lubricator
QZUU	With end seal + QZ
QZSS	With end seal + side seal + inner seal + QZ
QZDD	With double seals + side seal + inner seal + QZ
QZZZ	With end seal + side seal + inner seal + metal scraper + QZ
QZKK	With double seals + side seal + inner seal + metal scraper + + QZ
QZSSHH	With end seal + side seal + inner seal + LaCS + QZ
QZDDHH	With double seals + side seal + inner seal + LaCS + QZ
QZZZHH	With end seal + side seal + inner seal + metal scraper + LaCS + QZ
QZKKHH	With double seals + side seal + inner seal + metal scraper + LaCS + QZ

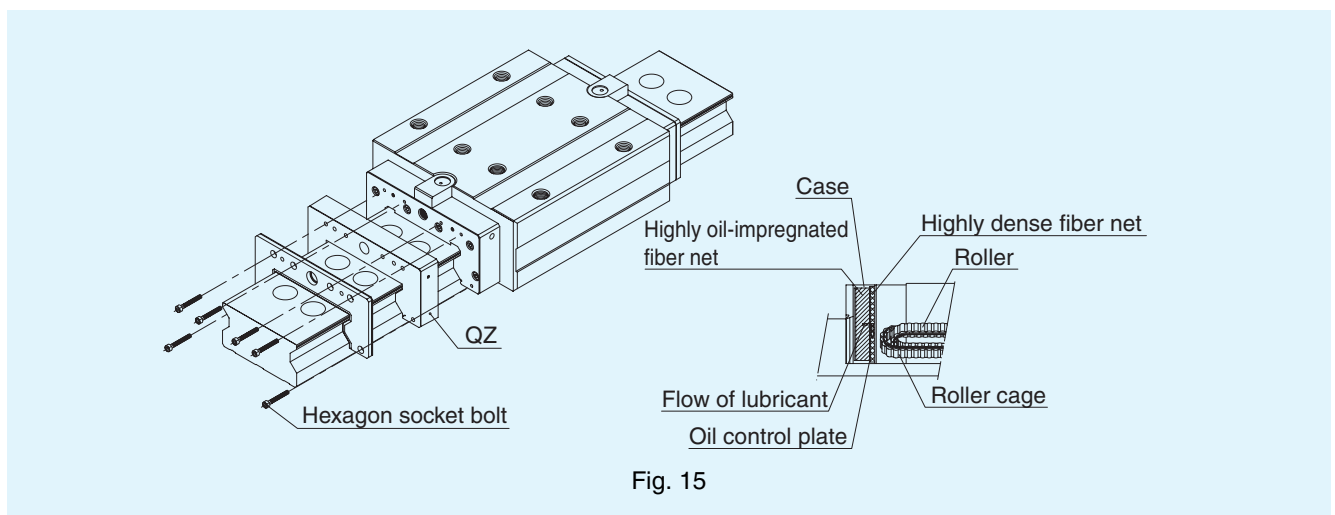

Table 7 Overall LM Block Length of Model SRW with QZ Lubricator Attached

Model No.	QZUU	QZSS	QZDD	QZZZ	QZKK	QZSSHH	QZDDHH	QZZZHH	QZKKHH
SRW 70	220	220	229.2	229.2	238.4	247	256.2	250.2	259.4
SRW 85	275	275	284.2	284.2	293.4	302	311.2	305.2	314.4
SRW 100	343	343	354.2	354.2	365.4	375.4	386.6	378.6	389.8

Unit: mm

Grease Port

Model SRW allows lubrication from both the side and top faces of the LM block. The grease port of standard types is not drilled through in order to prevent foreign matter from entering the LM block. When using the grease port, contact THK.

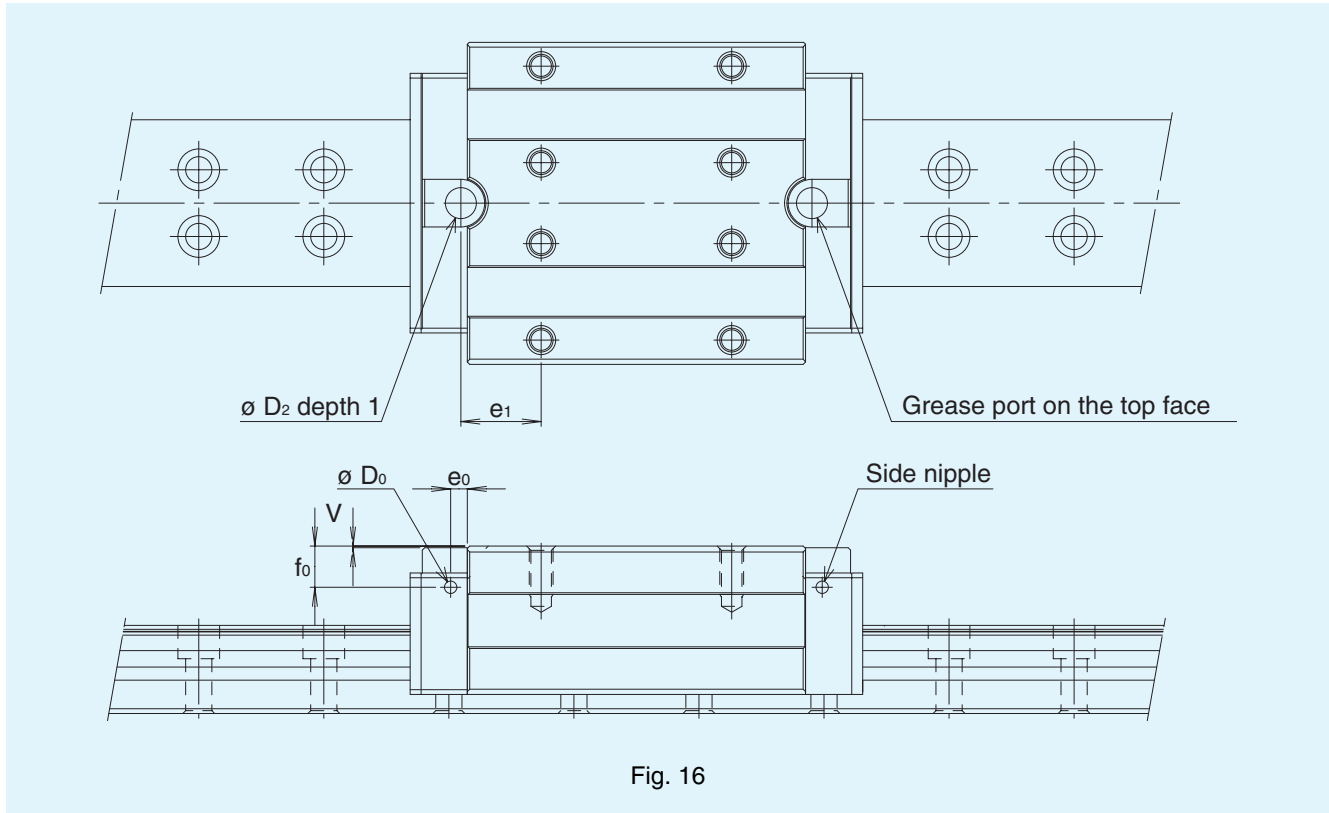

Table 8 Dimensions of the Grease Port

Unit: mm

Model No.	Pilot hole for side nipple			Applicable nipple	Grease port on the top face		
	e_0	f_0	D_0		D_2 (O ring)	V	e_1
SRW 70	7	17	5.2	M6F	13 (P ₁₀)	0.4	33.7
SRW 85	9	17.7	5.2	M6F	13 (P ₁₀)	0.4	42.75
SRW 100	9	22.4	5.2	M6F	13 (P ₁₀)	0.4	55

Rated Load and Service Life

Model SRW is capable of receiving all loads applied in the radial, reverse-radial and lateral directions. The basic load rating provided in the dimensional table indicates the rated load in the radial direction.

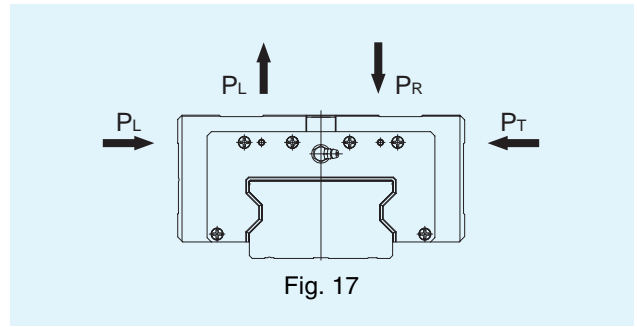

Service Life Calculation

The service life of model SRW is calculated from the equation below.

$$L = \left(\frac{f_T \cdot f_C}{f_W} \cdot \frac{C}{P_C} \right)^{\frac{10}{3}} \times 100$$

where

- L : Rated life
(The total travel distance that 90% of a group of units of the same LM Guide style can achieve without flaking after individually running under the same conditions)
- C : Basic dynamic load rating
- P_C : Calculated load
- f_T : Temperature factor (see the general catalog)
- f_C : Contact factor (see the general catalog)
- f_W : Load factor (see the general catalog)

$$L_h = \frac{L \times 10^3}{2 \times \ell_s \times n_1 \times 60}$$

where

- L_h : Service life time
- ℓ_s : Stroke length
- n_1 : Reciprocations per minute

Rated Load

Model SRW is capable of receiving all loads applied in the radial, reverse-radial and lateral directions. The basic load ratings are equal in all four directions (radial, reverse-radial and lateral directions), and their values are indicated in the dimensional table.

Equivalent Load

When the LM block of model SRW receives loads in all directions simultaneously, the equivalent load is obtained from the equation below.

$$P_E = P_R(P_L) + P_T$$

where

- P_E : Equivalent load
 - Radial direction
 - Reverse-radial direction
 - Lateral direction
- P_R : Radial load
- P_L : Reverse-radial load
- P_T : Lateral load

Moment Equivalent Factor

If a moment load is applied to a single LM block or a pair of two LM blocks in close contact with each other, convert the moment load into an equivalent load by multiplying the moment load by the moment equivalent factor indicated in table 9. For details, see the General Catalog - Technical Descriptions of the Products (catalog No. 400).

$$P = K \cdot M$$

where

- P : Equivalent load per LM Guide
- K : Moment equivalent factor
- M : Applied moment

Table 9 Moment Equivalent Factors

Model No.	Equivalent factor							
	K_{AR1}	K_{AL1}	K_{AR2}	K_{AL2}	K_{B1}	K_{B2}	K_{CR}	K_{CL}
SRW 70	4.18×10^{-2}		7.93×10^{-3}		4.18×10^{-2}	7.93×10^{-3}	2.52×10^{-2}	
SRW 85	3.37×10^{-2}		6.42×10^{-3}		3.37×10^{-2}	6.42×10^{-3}	2.09×10^{-2}	
SRW 100	2.63×10^{-2}		4.97×10^{-3}		2.63×10^{-2}	4.97×10^{-3}	1.77×10^{-2}	

- K_{AR1} : Equivalent factor in the MA radial direction when one LM block is used
- K_{AL1} : Equivalent factor in the MA reverse-radial direction when one LM block is used
- K_{AR2} : Equivalent factor in the MA radial direction when two LM blocks are used in close contact with each other
- K_{AL2} : Equivalent factor in the MA reverse-radial direction when two LM blocks are used in close contact with each other

- K_{B1} : MB Equivalent factor when one LM block is used
- K_{B2} : MB Equivalent factor when two LM blocks are used in close contact with each other
- K_{CR} : Equivalent factor in the MC radial direction
- K_{CL} : Equivalent factor in the MC reverse-radial direction

Precautions on Use

Height of the Mounting Surface and the Shape of the Corner

For the shoulder heights of the mounting surfaces for the LM rail and the LM block, we recommend selecting the corresponding values from table 10. The corner of the mounting surface must be recessed, or must be machined so that the corner radius is equal to or below the corner radius (of the LM block/LM rail) indicated in table 10, in order not to interfere with the chamfer of the LM block or the LM rail.

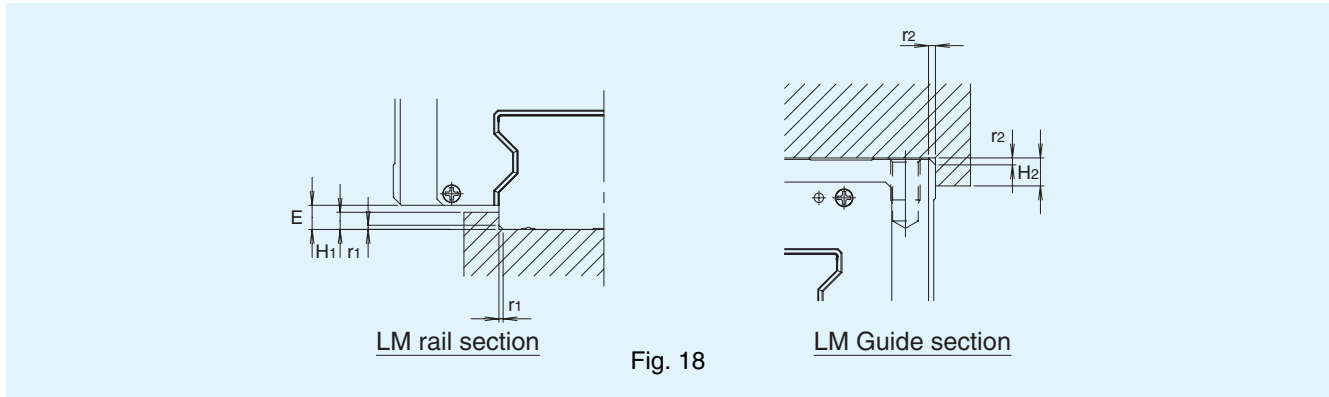

Table 10 Shoulder Height of the Mounting Surface and Corner Radius

Unit: mm

Model No.	Corner radius (LM rail section) r_1 (max)	Corner radius (LM block section) r_2 (max)	Shoulder height (LM rail section) H_1	Shoulder height (LM block section) H_2	E
SRW 70	1.5	1.5	6	8	8
SRW 85	1.5	1.5	8	10	10
SRW 100	1.5	2	9	10	11.5

Removing/mounting Jig

When assembling the guide, do not remove the LM block from the LM rail whenever possible. If it is inevitable to remove or mounting the LM block due to the assembly procedure, be sure to use the removing/mounting jig.

Mounting the LM block without using the removing/mounting jig may lead rolling elements to fall off from the LM block due to inclusion of foreign matter, damage to an internal part or a slight gradient. Also, be sure not to mount and use the LM block with some of the rolling elements missing, since doing so may result in early fracture of the LM system.

When using the removing/mounting jig, be careful not to tilt it and be sure to match the end face of the jig with that of the LM rail.

If any of the rolling elements has fallen off from the LM block, stop using the system and contact THK.

The removing/mounting jig is not provided as standard. When desiring to use it, contact THK.

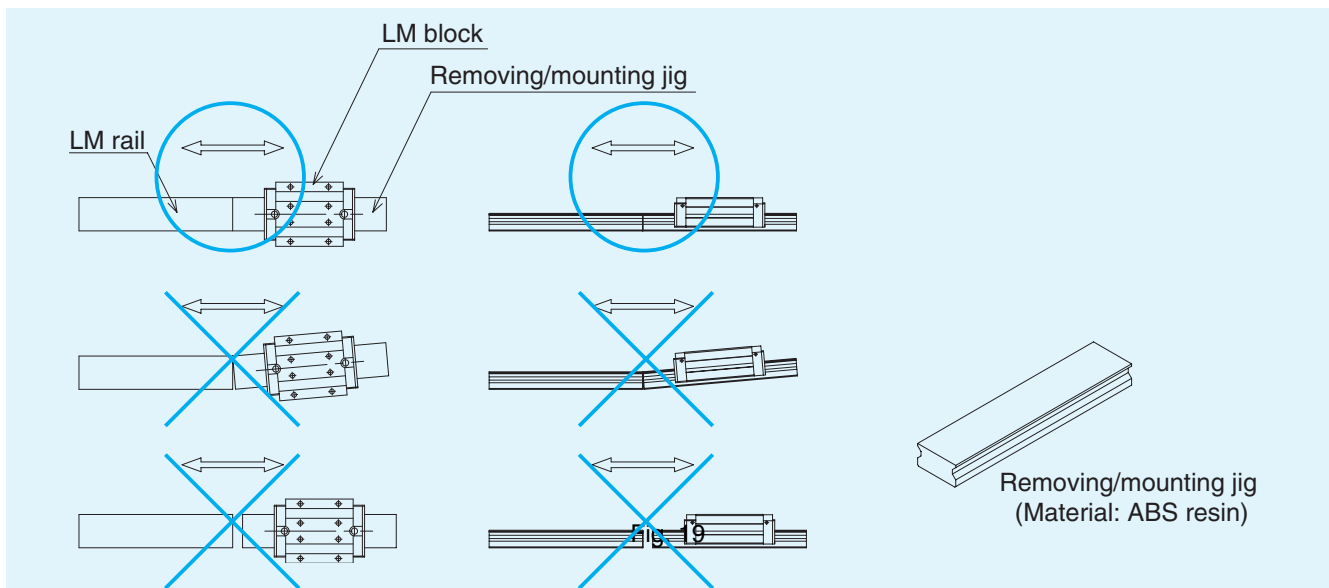

Accuracy of the Mounting Surface

Model SRW is highly rigid since it uses rollers as its rolling elements, and the roller cage prevents the rollers from skewing. However, the mounting surface needs to be finished with high accuracy.

The following tables show error allowances of the mounting surface that will not affect the rolling resistance or service life in normal operation.

Table 11 Error in Parallelism (P) between Two Rails

Unit: mm

Radial clearance Model No.	Normal	C ₁	C ₀
SRW 70	0.013	0.009	0.007
SRW 85	0.016	0.011	0.008
SRW 100	0.020	0.014	0.011

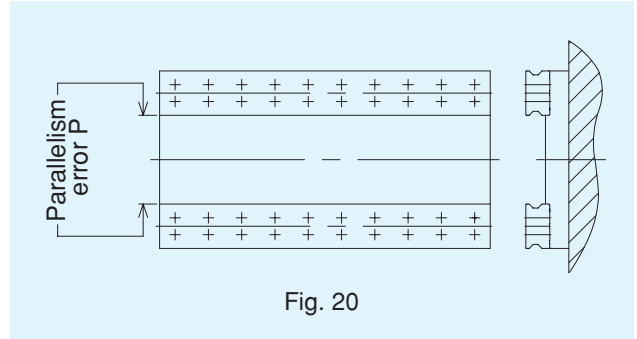

Fig. 20

Table 12 Error in Level (X) between the Rails

Unit: mm

Radial clearance	Normal	C ₁	C ₀
Error allowance (X) of the mounting surface	0.00020a	0.00014a	0.000072a

Table 13 Error in Level (Y) in the Axial Direction

Unit: mm

Accuracy of the mounting surface	0.000036 · b
----------------------------------	--------------

$X = X_1 + X_2$ X₁: Level difference on the rail mounting surface
X₂: Level difference on the block mounting surface

Example of calculation

Rail span
when a = 500 mm
Accuracy of the mounting surface
 $X = 0.0002 \times 500$
= 0.1

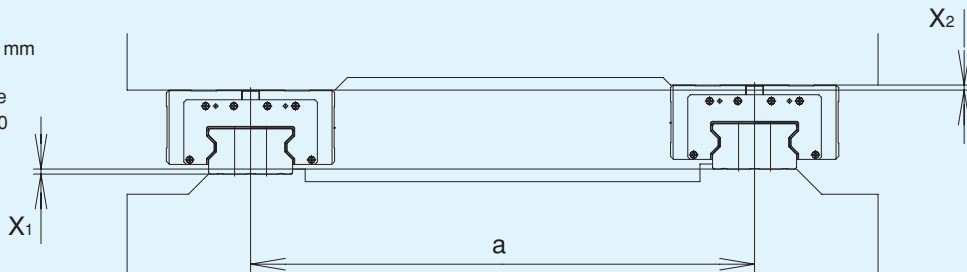

Fig. 21

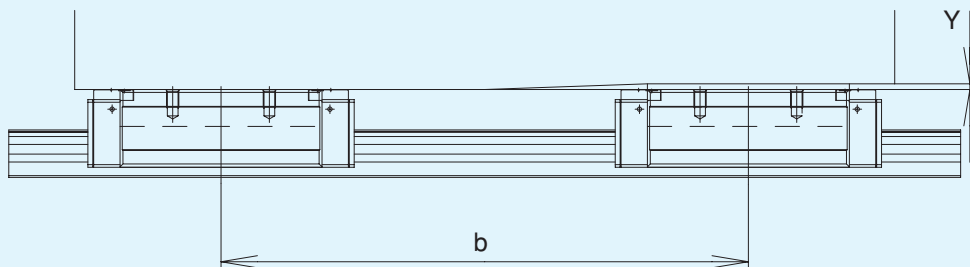

Fig. 22

Accuracy Standards

As shown in table 14, the accuracy of model SRW is specified in terms of running parallelism, dimensional tolerance for height and width, and height and width difference between a pair when 2 or more LM blocks are used on one rail or when 2 or more rails are mounted on the same plane.

Running parallelism

See the general catalog for details.

Difference in Height M

See the general catalog for details.

Difference in Width W2

See the general catalog for details.

Table 14 Accuracy Standards

Unit: mm

Mode No.	Accuracy standard	Precision grade	Super-precision grade	Ultra-super precision grade
	Item	P	SP	UP
SRW70 SRW85	Dimensional tolerance for height M	0 -0.05	0 -0.03	0 -0.02
	Difference in height M	0.007	0.005	0.003
	Dimensional tolerance for width W ₂	0 -0.05	0 -0.03	0 -0.02
	Difference in width W ₂	0.01	0.007	0.005
	Running parallelism of surface C against surface A	ΔD (as shown in Fig. 23 and 24)		
	Running parallelism of surface D against surface B	ΔD (as shown in Fig. 23 and 24)		
SRW100	Dimensional tolerance for height M	0 -0.07	0 -0.05	0 -0.03
	Difference in height M	0.01	0.007	0.005
	Dimensional tolerance for width W ₂	0 -0.07	0 -0.05	0 -0.03
	Difference in width W ₂	0.015	0.01	0.007
	Running parallelism of surface C against surface A	ΔC (as shown in Fig. 23 and 24)		
	Running parallelism of surface D against surface B	ΔD (as shown in Fig. 23 and 24)		

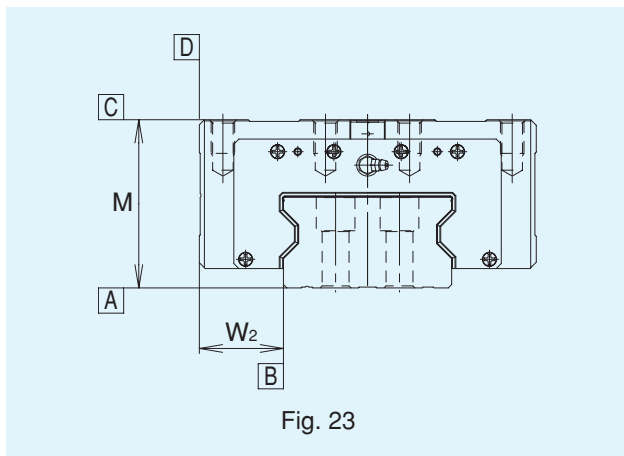

Fig. 23

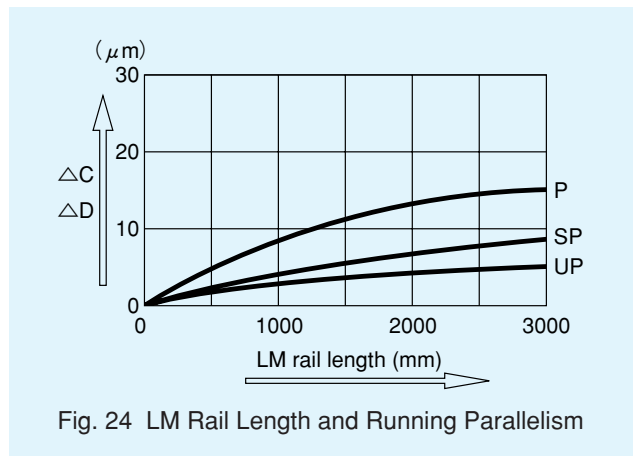

Fig. 24 LM Rail Length and Running Parallelism

Radial Clearance

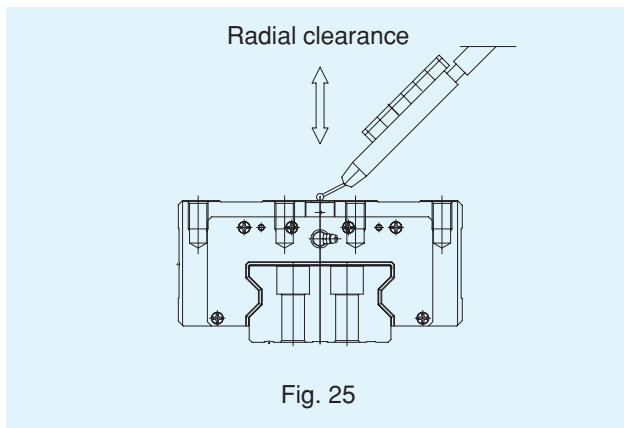

Fig. 25

Table 15 shows radial clearance of model SRW.

Table 15 Radial Clearance of Model SRW

Unit: μm

Model No.	Indication symbol	Normal	Light preload	Medium preload
	No symbol	C ₁	C ₀	
SRW 70	-2 ~ -1	-3 ~ -2	-5 ~ -3	
SRW 85	-2 ~ -1	-4 ~ -2	-6 ~ -4	
SRW 100	-3 ~ -1	-5 ~ -3	-8 ~ -5	

Note: Add no symbol for normal clearance; add C₀ or C₁ to the model number for clearance C₀ or clearance C₁, respectively. (See the model number coding.)

Standard Length and Maximum Length of the LM Rail

Table 16 shows the standard lengths and the maximum lengths of model SRW variations. If the maximum length of the desired LM rail exceeds them, two (or more) rails are connected when the Roller Guide is manufactured.

For the G dimension when a special length is required, we recommend selecting the corresponding G value from the table. The longer the G dimension is, the less stable the G area may become after installation, thus causing an adverse impact to accuracy.

If desiring a connected-rail type, be sure to indicate the overall length so that we can manufacture the Roller Guide without leaving a level difference in the joint.

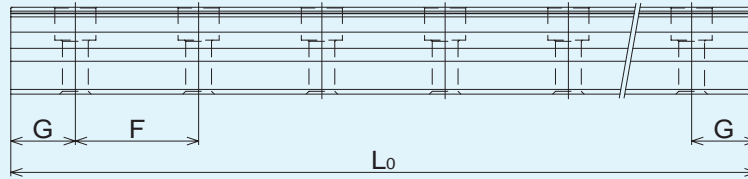

Fig. 26

Table 16 Standard Length and Maximum Length of the LM Rail of Model SRW

Unit: mm

	SRW70	SRW85	SRW100
Standard length (L_0)	570	780	1270
	675	900	1570
	780	1020	2020
	885	1140	2620
	990	1260	
	1095	1380	
	1200	1500	
	1305	1620	
	1410	1740	
	1515	1860	
	1620	1980	
	1725	2100	
	1830	2220	
	1935	2340	
	2040	2460	
	2145	2580	
	2250	2700	
	2355	2820	
	2460	2940	
	2565	3060	
2670			
2775			
2880			
2985			
Standard pitch F	52.5	60	75
G	22.5	30	35
Maximum length	3090	3060	3000

Note: • The maximum length varies with accuracy grades. Contact THK for details.

• If connected rails are not allowed and a greater length than the maximum values above is required, contact THK.

Dimensional Table for Model SRW ... LR

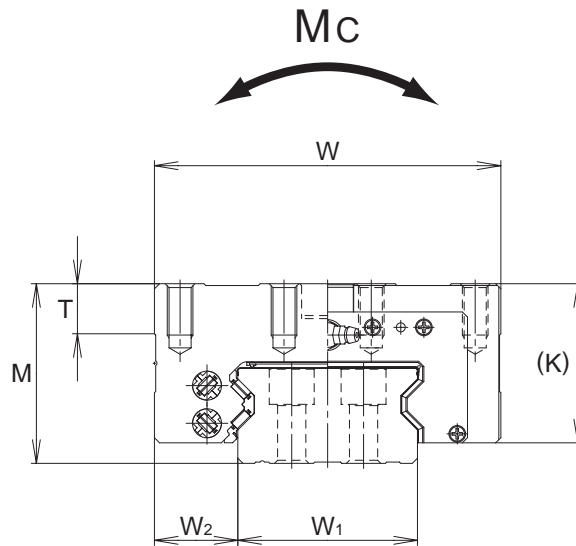

Model No.	Outer dimensions			LM block length											Grease nipple	
	Height M	Width W	Length L	B	B ₁	C	S × r	L ₁	T	K	N	E	e ₀	f ₀		D ₀
SRW70LR	70	135	190	115	34	80	M10 × 20	142	20	62	20	16	7	17	5.2	B-PT1/8
SRW85LR	80	165	235	140	40	95	M12 × 19	179.2	28	70	22	16	9	17.7	5.2	B-PT1/8
SRW100LR	100	200	303	172	50	110	M14 × 20	229.8	20	88.5	27	16	9	22.4	5.2	B-PT1/8

Model number coding

SRW70LR **2** **QZ** **KKHH** **CO** **+1200L** **P** **-II**

1
2
3
4
5
6
7
9

- 1** Model number
- 2** No. of LM blocks to be used on the same axis.
- 3** QZ Lubricator
- 4** Symbol for dust prevention accessory (note 1) (see page 4)
- 5** Radial clearance symbol (see page 11)
- 6** LM rail length (mm) (note 2)
- 7** Accuracy symbol (see page 11)
- 9** No. of shafts used on the same plane

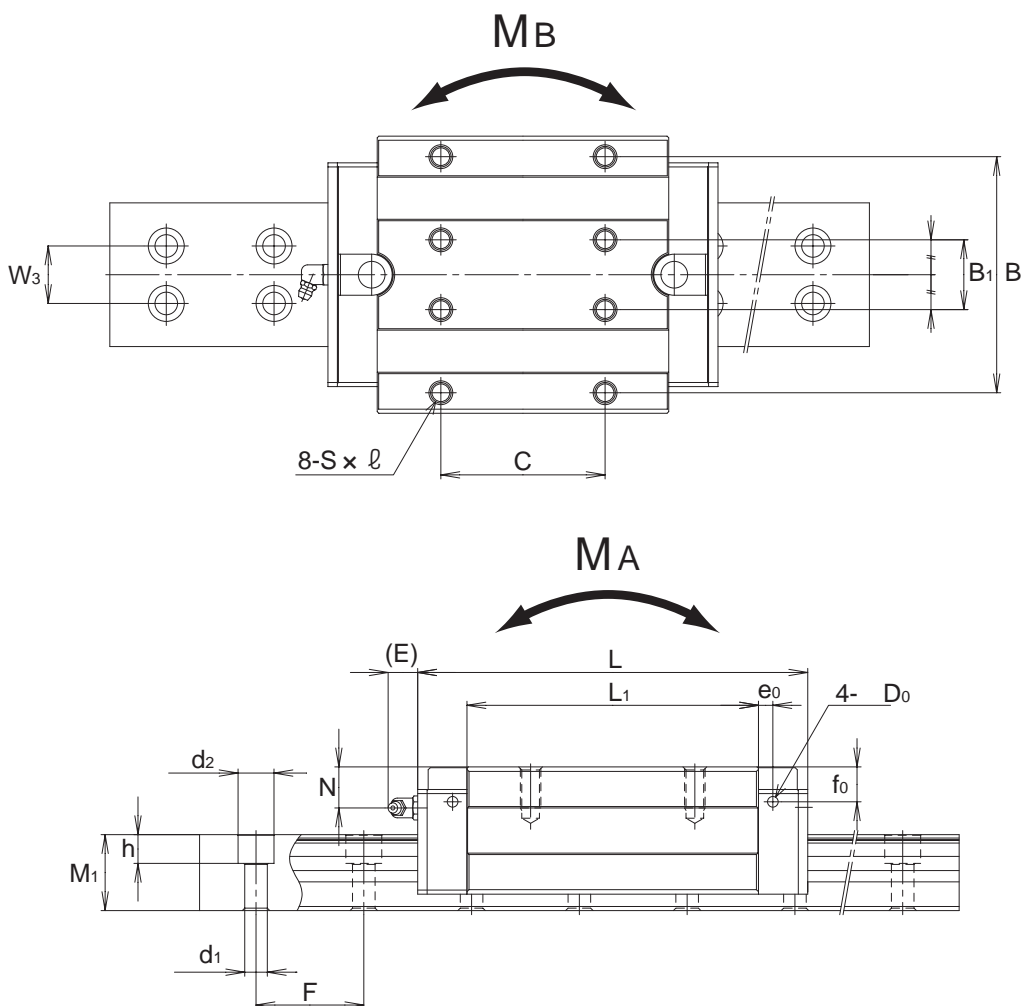

Unit: mm

LM rail dimensions						Basic load rating		Permissible static moment kN·m					Mass	
Width			Height	Pitch		C	C ₀	M _A		M _B		M _C	LM block	LM rail
W _{1-0.05}	W ₂	W ₃	M ₁	F	d ₁ × d ₂ × h	kN	kN	1 block	2 blocks in close contact	1 block	2 blocks in close contact	1 block	kg	kg/m
70	32.5	28	37	52.5	11 × 17.5 × 14	115	256	6.13	32.2	6.13	32.2	10.2	6.3	18.6
85	40	32	43	60	14 × 20 × 17	167	366	10.8	57	10.8	57	17.5	11.0	26.7
100	50	38	54	75	16 × 23 × 20	278	599	22.7	120	22.7	120	33.9	21.6	35.9



Note 1: Model SRW is attached with "SS" as standard.

Note 2: This model number indicates that a single-rail unit constitutes one set (i.e., required number of sets when 2 rails are used in parallel is 2 at a minimum).

Note 3: For the standard LM rail length, see table 15 on page 12.

Note 4: The greasing hole on the top face and the pilot hole of the side nipple* are not drilled through in order to prevent foreign matter from entering the block. See page 8 for details.

Note 5: The removing/mounting jig is not provided as standard. When desiring to use it, contact THK.