



Ball Spline Series

Optimal for mechanisms that perform linear motion while transmitting a torque
Capable of high-speed motion and high-speed rotation
A wide array of lineups



Contents

Ball Spline Series

- 1. Structure and Features P. 2
- 2. Classification P. 3
- 3. Conditions and Guidelines for
Selecting of a Preload P. 5
- 4. Accuracy P. 7
- 5. Dimensional Tables
 - Model LT P. 9
 - Model LF P. 11
 - Model LBS P. 13
 - Model LBST P. 15
 - Model LBF P. 16
 - Model LBR P. 17
 - Model LBH P. 18
 - Model LTR-A P. 19
 - Model LTR P. 21

Medium-torque Type

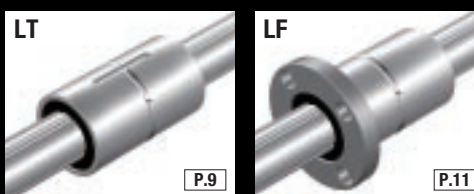

High-torque Type

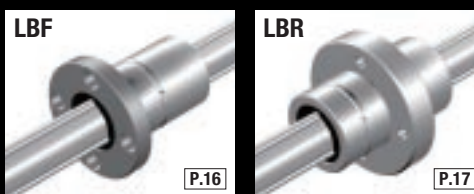

Rotary Type

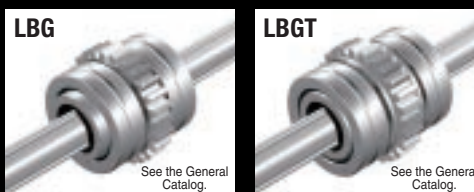
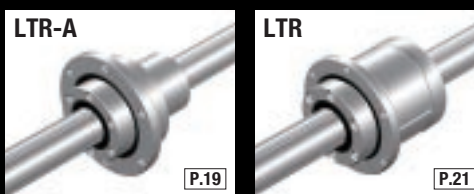

Ball Spline Series

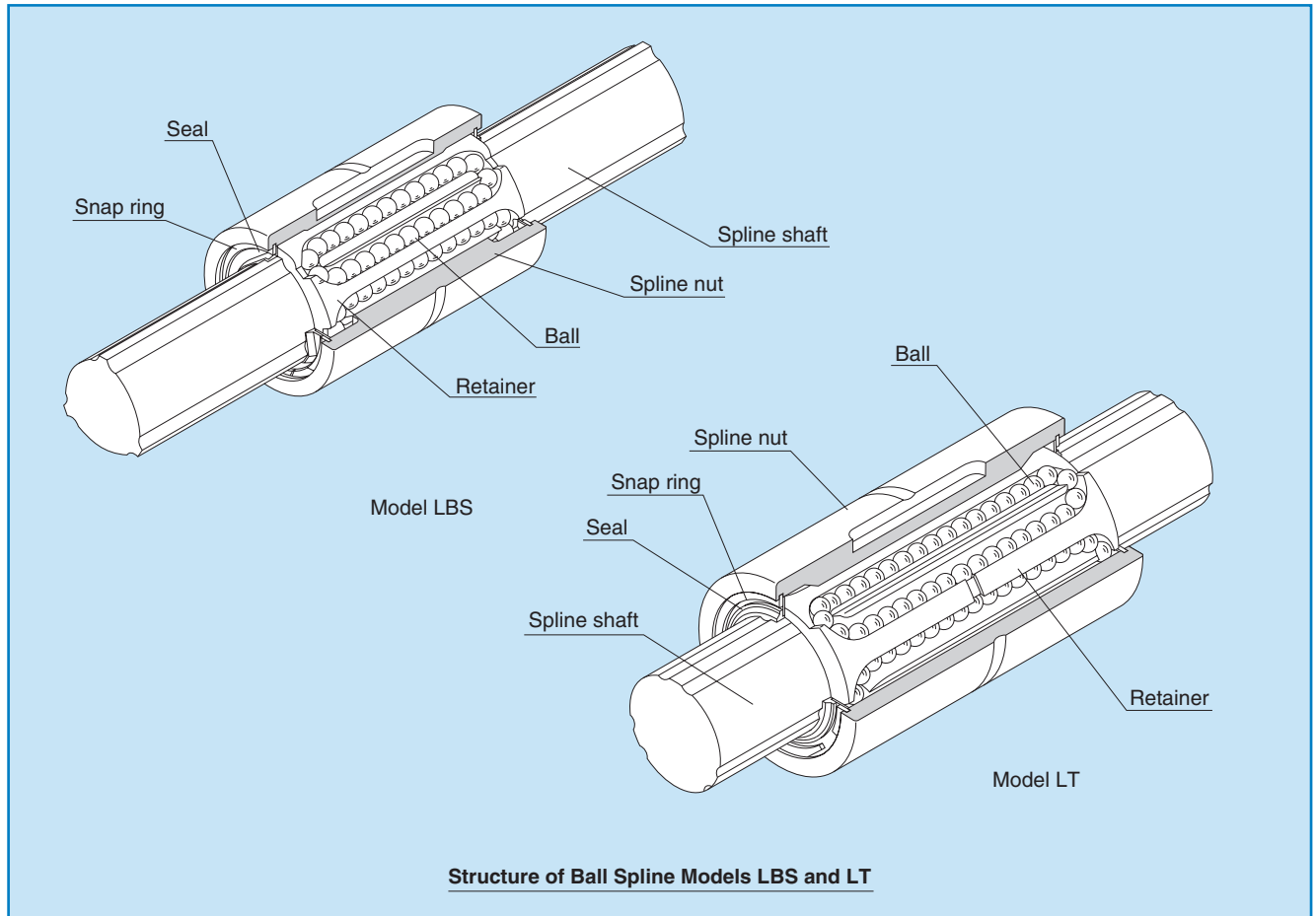

Structure and Features

The Ball Spline is an innovative linear motion system in which balls accommodated in the spline nut transmit torque while linearly moving on precision-ground raceways on the spline shaft.







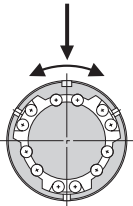

Unlike the conventional structure, a single spline nut can provide a preload with THK's Ball Spline. As a result, the Ball Spline demonstrates high performance in environments subject to vibrations and impact loads, locations where a high level of positioning accuracy is required or areas where high-speed kinetic performance is required.

In addition, even when used as an alternative to a linear bushing, the Ball Spline achieves a rated load more than 10 times greater than the linear bushing with the same shaft diameter, allowing it to compactly be designed and used in locations where an overhung load or a moment load is applied.

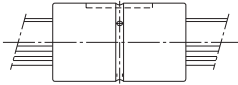
Thus, the Ball Spline provides a high degree of safety and long service life.

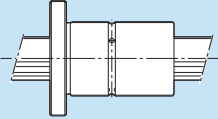
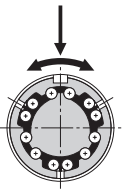
Classification of Ball Splines

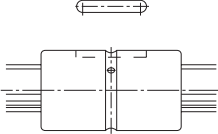
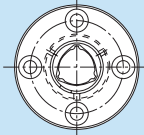
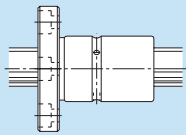
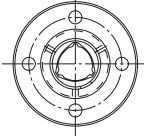
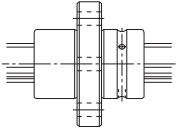
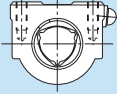
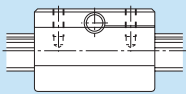
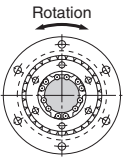
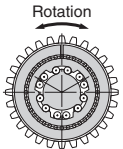
There are three types of the Ball Spline: medium-torque type, high-torque type and rotary type. You can choose a type according to the intended use. In addition, wide arrays of spline nut shapes are available for each type, enabling the user to choose a desired shape according to the mounting or service requirements.

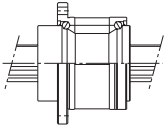
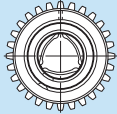
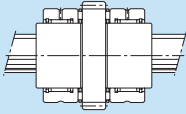
Classification		Type	Shape		Shaft diameter
Medium-torque type		Model LT			Nominal shaft diameter: 4 to 100 mm
		Model LF			Nominal shaft diameter: 6 to 50 mm
High-torque type		Model LBS Model LBST			Nominal shaft diameter: 6 to 150 mm
		Model LBF			Nominal shaft diameter: 15 to 100 mm
		Model LBR			Nominal shaft diameter: 15 to 100 mm
		Model LBH			Nominal shaft diameter: 15 to 50 mm
Rotary type	 	Model LTR-A Model LTR			Nominal shaft diameter: 8 to 60 mm
		Model LBG Model LBGT			Nominal shaft diameter: 20 to 85 mm

	Structure and features	Major applications
	<ul style="list-style-type: none"> ● The spline shaft has two to three crests. On both sides of each crest, two rows (four to six rows in total) of balls are arranged to hold the crest from both sides. This design allows an appropriate preload to be evenly applied. ● The contact angle of 20° and an appropriate preload level eliminate angular backlash, providing high-torque moment rigidity. 	<ul style="list-style-type: none"> ● Shaft for die setting and similar applications requiring linear motion under a heavy load. ● Loading system and similar applications requiring rotation to a given angle at a fixed position. ● Automatic gas-welding machine spindle and similar applications requiring a whirl-stop on one shaft. ● Column and arm of industrial robot ● Spot-welding machine ● Riveting machine ● Book-binding machine ● Automatic filler ● XY recorders ● Automatic spinner ● Optical measuring instrument
	<ul style="list-style-type: none"> ● The spline shaft has three crests equidistantly formed at angles of 120°. On both sides of each crest, two rows (six rows in total) of balls are arranged to hold the crest from both sides. The angular-contact design of the ball contact areas allows an appropriate preload to be evenly applied. ● Since the balls circulate inside the spline nut, the outer dimensions of the spline nut are compactly designed. ● Even under a large preload, smooth linear motion is achieved. ● Since the contact angle is large (45°) and the displacement is minimal, high rigidity is achieved. ● No angular backlash occurs. ● Capable of transmitting a large torque. 	<ul style="list-style-type: none"> ● Column and arm of industrial robot ● Automatic loader ● Transfer machine ● Automatic conveyance system ● Tire molding machine ● Spindle of spot-welding machine ● Guide shaft of high-speed automatic coating machine ● Riveting machine ● Wire winder ● Work head of electric discharge machine ● Spindle drive shaft of grinding machine ● Speed gears ● Precision indexing shaft
	<ul style="list-style-type: none"> ● A lightweight, compact type based on model LT, but has a spline nut circumference machined to have angular-contact type ball raceways to accommodate support bearings. 	<ul style="list-style-type: none"> ● Z axis of scalar robot ● Wire winder
	<ul style="list-style-type: none"> ● A unit type that has the same contact structure as model LBS. The flange circumference on the spline nut is machined to have gear teeth, and radial and thrust needle bearings are compactly combined on the circumference of the spline nut. 	<ul style="list-style-type: none"> ● Speed gears for high-torque transmission

Conditions and Guidelines for Selecting of a Preload

Table 1 provides guidelines for selecting a clearance in the rotational direction with given conditions of the Ball Spline.

The rotational clearance of the Ball Spline significantly affects the accuracy and rigidity of the spline nut. Therefore, it is essential to select a correct clearance according to the intended use. Generally, the Ball Spline is provided with a preload. When it is used in repeated circular motion or reciprocating straight motion, the Ball Spline is subject to a large vibration impact, and therefore, its service life and accuracy are significantly increased with a preload.

Table 1 Guidelines for Selecting a Clearance in the Rotational Direction for the Ball Spline

Clearance in rotational direction	Service conditions	Example of application
Medium preload (CM)	<ul style="list-style-type: none"> ● High rigidity is required and vibration impact is present. ● Receives a moment load with a single spline nut. 	Steering shaft of construction vehicle; shaft of spot-welding machine; indexing shaft of automatic lathe tool rest
Light preload (CL)	<ul style="list-style-type: none"> ● An overhung load or moment is present. ● High positioning accuracy is required. ● Alternating load is applied. 	Industrial robot arm; automatic loaders; guide shaft of automatic coating machine; main shaft of electric discharge machine; guide shaft for press die setting; main shaft of drilling machine
Normal grade (No symbol)	<ul style="list-style-type: none"> ● Smooth motion with a small force is desired. ● A torque is always applied in the same direction. 	Measuring instruments; automatic drafting machine; geometrical measuring equipment; dynamometer; wire winder; automatic welding machine; main shaft of honing machine; automatic packing machine

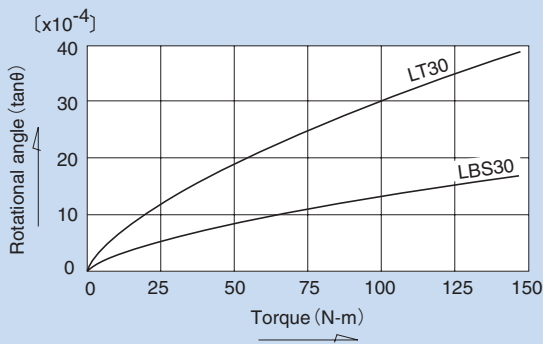

Fig. 1 Comparison between LBS and LT for Zero Clearance

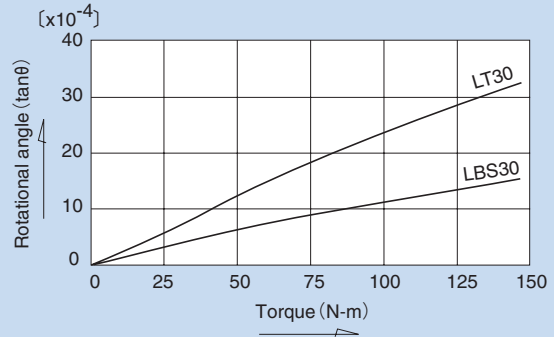

Fig. 2 Comparison between LBS and LT for Clearance CL

Table 2 Clearance in the Rotational Direction for Models LT and LF

Unit: μm

Nominal shaft diameter	Symbol	Normal	Light preload	Medium preload
		No symbol	CL	CM
4 5 6 8 10 13		- 2 to +1	- 6 to - 2	—
16 20		- 2 to +1	- 6 to - 2	- 9 to - 5
25 30		- 3 to +2	-10 to - 4	-14 to - 8
40 50		- 4 to +2	-16 to - 8	-22 to -14
60 80		- 5 to +2	-22 to -12	-30 to -20
100		- 6 to +3	-26 to -14	-36 to -24

Table 3 Clearance in the Rotational Direction for Models LBS, LBF, LBST, LBR and LBH

Unit: μm

Nominal shaft diameter	Symbol	Normal	Light preload	Medium preload
		No symbol	CL	CM
6 8		- 2 to +1	- 6 to - 2	—
10 15		- 3 to +2	- 9 to - 3	-15 to - 9
20 25 30		- 4 to +2	-12 to - 4	-20 to -12
40 50 60		- 6 to +3	-18 to - 6	-30 to -18
70 85		- 8 to +4	-24 to - 8	-40 to -24
100 120		-10 to +5	-30 to -10	-50 to -30
150		-15 to +7	-40 to -15	-70 to -40

Table 4 Clearance in the Rotational Direction for Model LTR

Unit: μm

Nominal shaft diameter	Symbol	Normal	Light preload	Medium preload
		No symbol	CL	CM
8 10		- 2 to +1	- 6 to - 2	—
16 20		- 2 to +1	- 6 to - 2	- 9 to - 5
25 32		- 3 to +2	-10 to - 4	-14 to - 8
40 50		- 4 to +2	-16 to - 8	-22 to -14
60		- 5 to +2	-22 to -12	-30 to -20

Accuracy Standards

The accuracy of the Ball Spline is classified into three grades: normal grade (no symbol), high grade (H) and precision grade (P), according to the run-out of spline nut circumference in relation to the support of the spline shaft. Fig. 3 shows the measurement items.

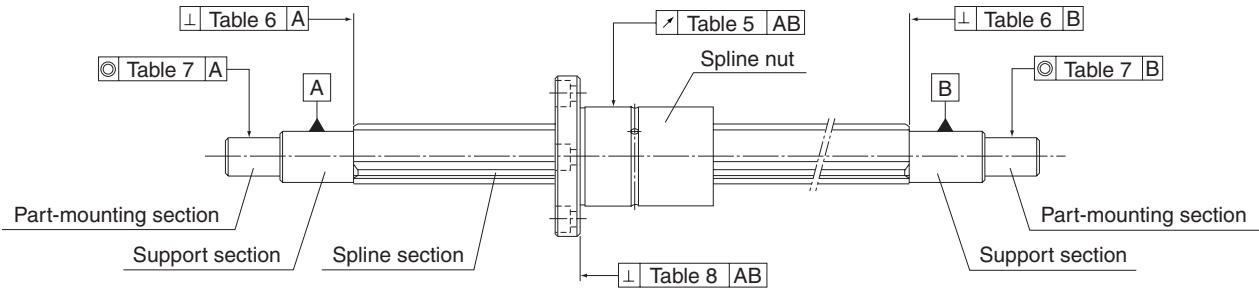

Fig.3 Accuracy Measurement Items for the Ball Spline

Table 5 Run-out of the Spline Nut Circumference in relation to the Support Section of the Spline Shaft

Unit: μm

Overall spline shaft length (mm)	Accuracy Nominal shaft diameter	Run-out (MAX)																							
		4 to 8 (See Note 1)			10			13 to 20			25 to 32			40、50			60 to 80			85 to 120			150		
Above	Or less	Normal	High	Precision	Normal	High	Precision	Normal	High	Precision	Normal	High	Precision	Normal	High	Precision	Normal	High	Precision	Normal	High	Precision	Normal	High	Precision
—	200	72	46	26	59	36	20	56	34	18	53	32	18	53	32	16	51	30	16	51	30	16	—	—	—
200	315	133	(89)	—	83	54	32	71	45	25	58	39	21	58	36	19	55	34	17	53	32	17	—	—	—
315	400	—	—	—	103	68	—	83	53	31	70	44	25	63	39	21	58	36	19	55	34	17	—	—	—
400	500	—	—	—	123	—	—	95	62	38	78	50	29	68	43	24	61	38	21	57	35	19	46	36	19
500	630	—	—	—	—	—	—	112	—	—	88	57	34	74	47	27	65	41	23	60	37	20	49	39	21
630	800	—	—	—	—	—	—	—	—	—	103	68	42	84	54	32	71	45	26	64	40	22	53	43	24
800	1000	—	—	—	—	—	—	—	—	—	124	83	—	97	63	38	79	51	30	69	43	24	58	48	27
1000	1250	—	—	—	—	—	—	—	—	—	—	—	—	114	76	47	90	59	35	76	48	28	63	55	32
1250	1600	—	—	—	—	—	—	—	—	—	—	—	—	139	93	—	106	70	43	86	55	33	80	65	40
1600	2000	—	—	—	—	—	—	—	—	—	—	—	—	—	—	—	128	86	54	99	65	40	100	80	50
2000	2500	—	—	—	—	—	—	—	—	—	—	—	—	—	—	—	156	—	—	117	78	49	125	100	68
2500	3000	—	—	—	—	—	—	—	—	—	—	—	—	—	—	—	—	—	—	143	96	61	150	129	84

Note 1: The dimension in parentheses does not apply to a nominal shaft diameter of 4.

Note 2: Applicable to models LBS, LBST, LBF, LBR, LT and LF.

Table 6 Perpendicularity of the Spline Section's End Face to the Support Section of the Spline Shaft

Unit: μm

Nominal shaft diameter	Accuracy	Perpendicularity (MAX)		
		Normal grade (No symbol)	High grade (H)	Precision grade (P)
4 5 6 8 10		22	9	6
13 15 16 20		27	11	8
25 30 32		33	13	9
40 50		39	16	11
60 70 80		46	19	13
85 100 120		54	22	15
150		63	25	18

Table 7 Concentricity of the Part-mounting Section in Relation to the Support Section of the Spline Shaft Unit: μm

Nominal shaft diameter \ Accuracy	Concentricity (MAX)		
	Normal grade (No symbol)	High grade (H)	Precision grade (P)
4 5 6 8	33	14	8
10	41	17	10
13 15 16 20	46	19	12
25 30 32	53	22	13
40 50	62	25	15
60 70 80	73	29	17
85 100 120	86	34	20
150	100	40	23

Table 8 Perpendicularity of the Spline Nut's Flange Mounting Surface to the Support Section of the Spline Shaft Unit: μm

Nominal shaft diameter \ Accuracy	Perpendicularity (MAX)		
	Normal grade (No symbol)	High grade (H)	Precision grade (P)
6 8	27	11	8
10 13	33	13	9
15 16 20 25 30	39	16	11
40 50	46	19	13
60 70 80 85	54	22	15
100	63	25	18

Note: Except models LBG, LBGT, LTR and LTR-A.

Maximum Manufacturing Length by Accuracy

Tables 9 and 10 show the maximum manufacturing lengths of the ball spline shafts by accuracy.

Table 9 Maximum Manufacturing Length of Models LBS, LBST, LBF, LBR and LBH by Accuracy

Unit: mm

Model No.	Accuracy		
	Normal grade (No Symbol)	High grade (H)	Precision grade (P)
6	200	150	100
8	600	200	150
10	600	400	300
15	1800	600	600
20	1800	700	700
25	3000	1400	1400
30	3000	1400	1400
40	3000	1400	1400
50	3000	1400	1400
60	3800	2500	2000
70	3800	2500	2000
85	3800	3000	3000
100	4000	3000	3000
120	3000	3000	3000
150	3000	3000	3000

Table 10 Maximum Manufacturing Length of Models LT, LF, LTR and LTR-A by Accuracy

Unit: mm

Model No.	Accuracy		
	Normal grade (No Symbol)	High grade (H)	Precision grade (P)
4	600	200	200
5	600	315	200
6	600	400	315
8	1000	500	400
10	1000	630	500
13	1000	800	630
16	2000	1000	1000
20	2000	1500	1000
25	3000	1500	1000
30	3000	1600	1250
40	3000	2000	1520
50	3000	2000	1500
60	4000	2000	2000
80	4000	2000	2000
100	4000	3000	3000

Note 1: The lengths in the table each represent the overall shaft length.

Note 2: For the standard hollow shaft type "K," the values in the table apply.

Note 3: For the standard hollow shaft type "N," the maximum lengths for the normal and high grades are limited to that of the precision grade (P).

Model LT

Dimensional Table for Model LT

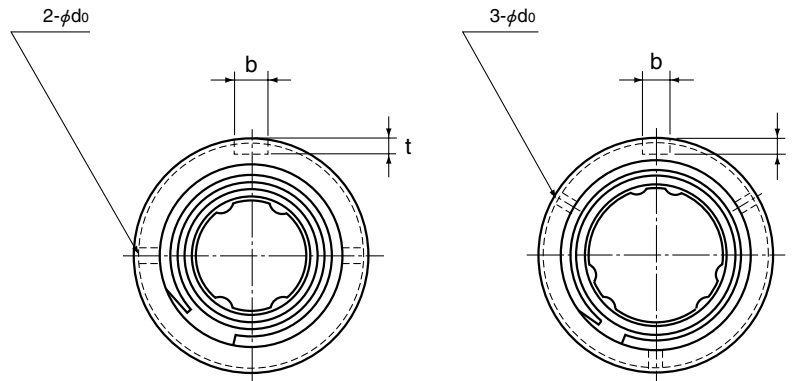

Model LT13 or smaller

Model LT16 or larger

Model No.	Spline nut dimensions								
	Outer diameter		Length		Keyway dimensions			r	Greasing hole d ₀
	D	Tolerance	L	Tolerance	b H8	t +0.05 0	ℓ ₀		
(See Note 1) LT 4	10	$\begin{smallmatrix} 0 \\ -0.009 \end{smallmatrix}$	16	0 -0.2	2	1.2	6	0.5	—
(See Note 1) LT 5	12	0 -0.011	20		2.5	1.2	8	0.5	—
LT 6	14		25		2.5	1.2	10.5	0.5	1
LT 8	16	25	2.5		1.2	10.5	0.5	1.5	
LT 10	21	0	33		3	1.5	13	0.5	1.5
LT 13	24	$\begin{smallmatrix} 0 \\ -0.013 \end{smallmatrix}$	36	3	1.5	15	0.5	1.5	
○ LT 16	31	0 -0.016	50	0 -0.3	3.5	2	17.5	0.5	2
○ LT 20	35		63		4	2.5	29	0.5	2
○ LT 25	42		71		4	2.5	36	0.5	3
○ LT 30	47		80		4	2.5	42	0.5	3
○ LT 40	64		0		100	6	3.5	52	0.5
○ LT 50	80	$\begin{smallmatrix} 0 \\ -0.019 \end{smallmatrix}$	125	0 -0.4	8	4	58	1	4
○ LT 60	90	0	140		12	5	67	1	5
○ LT 80	120	$\begin{smallmatrix} 0 \\ -0.022 \end{smallmatrix}$	160		16	6	76	2	5
○ LT 100	150	$\begin{smallmatrix} 0 \\ -0.025 \end{smallmatrix}$	185		20	7	110	2.5	5
					20	7	110	2.5	5

Note 1: Models LT4 and 5 do not use a retainer. Do not remove the shaft from the spline nut (doing so will cause balls to fall off).

Note 2: ○: For those models, high-temperature types (metal retainer, service temperature: up to 100°C) are available.

(Example) LT20 $\overset{\text{A}}{\text{CL}}$ +500L H

Symbol for high-temperature type

Example of model number coding

2 LT30 UU CL +500L H K

Model number	Symbol for clearance in the rotational direction (see page 6)	Accuracy symbol (see page 7)	Symbol for standard hollow spline shaft (no symbol: solid spline shaft)
Number of spline nuts on one shaft (no symbol for one spline nut)	Overall spline shaft length (in mm)	Dust prevention accessory symbol	No symbol: without seal
	UU: rubber seal attached on both ends of spline nut	U: rubber seal attached on either end of spline nut	

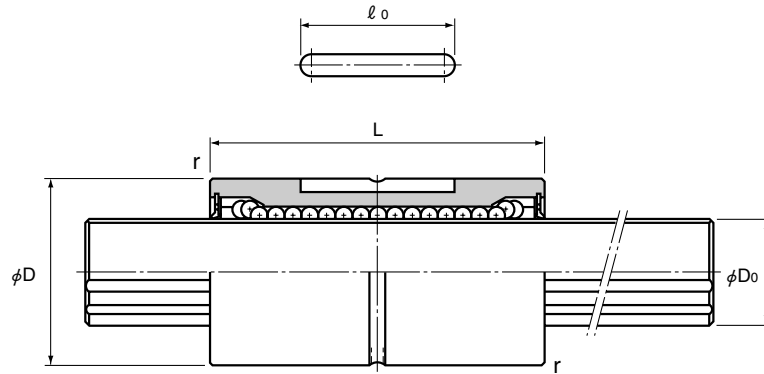

Unit: mm

Spline shaft diameter	No. of rows of balls	Basic torque rating		Basic load rating		Static permissible moment		Mass	
		C_T [N-m]	C_{OT} [N-m]	C [kN]	C_0 [kN]	M_{A1} (See Note 3) [N-m]	M_{A2} (See Note 3) [N-m]	Spline nut [g]	Spline shaft [kg/m]
D_0 h7									
4	4	0.59	0.78	0.44	0.61	0.88	6.4	5.2	0.1
5	4	0.88	1.37	0.66	0.88	1.5	11.6	9.1	0.15
6	4	0.98	1.96	1.18	2.16	4.9	36.3	17	0.23
8	4	1.96	2.94	1.47	2.55	5.9	44.1	18	0.4
10	4	3.92	7.84	2.84	4.9	15.7	98	50	0.62
13	4	5.88	10.8	3.53	5.78	19.6	138	55	1.1
16	6	31.4	34.3	7.06	12.6	67.6	393	165	1.6
20	6	56.9	55.9	10.2	17.8	118	700	225	2.5
25	6	105	103	15.2	25.8	210	1140	335	3.9
30	6	171	148	20.5	34	290	1710	375	5.6
40	6	419	377	37.8	60.5	687	3760	1000	9.9
50	6	842	769	60.9	94.5	1340	7350	1950	15.5
60	6	1220	1040	73.5	111.7	1600	9990	2500	22.3
80	6	2310	1920	104.9	154.8	2510	16000	4680	39.6
100	6	3730	3010	136.2	195	3400	24000	9550	61.8

Note 3: M_{A1} indicates the permissible moment value in the axial direction when one spline nut is used.

M_{A2} indicates the permissible moment value in the axial direction when two spline nuts are used.

(Using a single LT unit is not stable in accuracy. We recommend using two units in close contact with each other.)

Note 4: For details on the maximum lengths of ball spline shafts by accuracy, please see page 8.

Model LF

Dimensional Table for Model LF

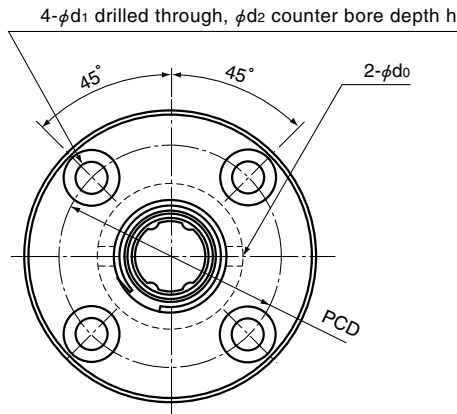

Model LF13 or smaller

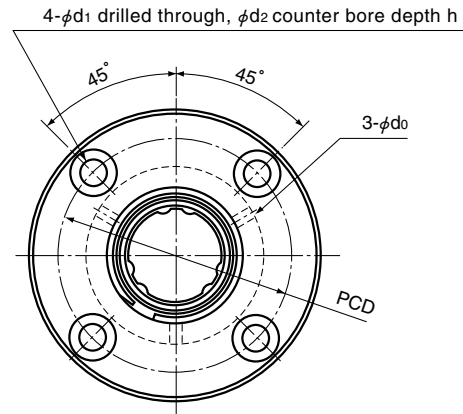

Model LF16 or larger

Model No.	Spline nut dimensions												
	Outer diameter		Length		Flange diameter		H	F	C	r	Greasing hole		Mounting hole $d_1 \times d_2 \times h$
	D	Tolerance	L	Tolerance	D_1	Tolerance					d_o	PCD	
LF 6	14	0	25	-0.2	30	-0.2	5	7.5	0.5	0.5	1.5	22	3.4×6.5×3.3
LF 8	16	-0.011	25		32		5	7.5	0.5	0.5	1.5	24	3.4×6.5×3.3
LF 10	21	0	33		42		6	10.5	0.5	0.5	1.5	32	4.5×8×4.4
LF 13	24	-0.013	36		44		7	11	0.5	0.5	1.5	33	4.5×8×4.4
○ LF 16	31	-0.016	50	-0.3	51	-0.2	7	18	0.5	0.5	2	40	4.5×8×4.4
○ LF 20	35		63		58		9	22.5	0.5	0.5	2	45	5.5×9.5×5.4
○ LF 25	42		71		65		9	26.5	0.5	0.5	3	52	5.5×9.5×5.4
○ LF 30	47		80		75		10	30	0.5	0.5	3	60	6.6×11×6.5
○ LF 40	64	0	100	-0.3	100	-0.2	14	36	1	0.5	4	82	9×14×8.6
○ LF 50	80	-0.019	125		124		16	46.5	1	1	4	102	11×17.5×11

Note 1: ○: For those models, high-temperature types (metal retainer, service temperature: up to 100°C) are available.

(Example) LF30 A CL+700L H

Symbol for high-temperature type

Example of model number coding

2 LF20 UU CM +400L P N

Model number Number of spline nuts on one shaft (no symbol for one spline nut)	Symbol for clearance in the rotational direction (see page 6)	Accuracy symbol (see page 7)	Symbol for standard hollow spline shaft (no symbol: solid spline shaft)
	Overall spline shaft length (in mm)		
	Dust prevention accessory symbol UU: rubber seal attached on both ends of spline nut	No symbol: without seal	U: rubber seal attached on either end of spline nut

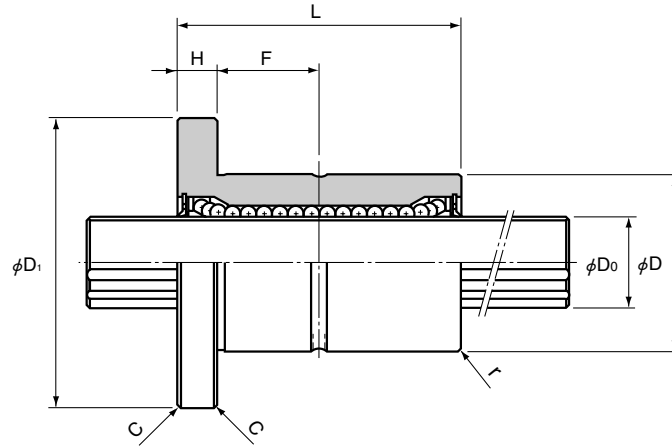

Unit: mm

Spline shaft diameter	No. of rows of balls	Basic torque rating		Basic load rating		Static permissible moment		Mass	
		C_T [N-m]	C_{OT} [N-m]	C [kN]	C_0 [kN]	M_{A1} (See Note 2) [N-m]	M_{A2} (See Note 2) [N-m]	Spline nut [g]	Spline shaft [kg/m]
6	4	0.98	1.96	1.18	2.16	4.9	36.3	35	0.23
8	4	1.96	2.94	1.47	2.55	5.9	44.1	37	0.4
10	4	3.92	7.84	2.84	4.9	15.7	98	90	0.62
13	4	5.88	10.8	3.53	5.78	19.6	138	110	1.1
16	6	31.4	34.3	7.06	12.6	67.6	393	230	1.6
20	6	56.9	55.9	10.2	17.8	118	700	330	2.5
25	6	105	103	15.2	25.8	210	1140	455	3.9
30	6	171	148	20.5	34	290	1710	565	5.6
40	6	419	377	37.8	60.5	687	3760	1460	9.9
50	6	842	769	60.9	94.5	1340	7350	2760	15.5

Note 2: M_{A1} indicates the permissible moment value in the axial direction when one spline nut is used.

M_{A2} indicates the permissible moment value in the axial direction when two spline nuts are used.

(Using a single LF unit is not stable in accuracy. We recommend using two units in close contact with each other.)

Note 3: For details on the maximum lengths of ball spline shafts by accuracy, please see page 8.

Model LBS

Dimensional Table for Model LBS - Medium Load Type

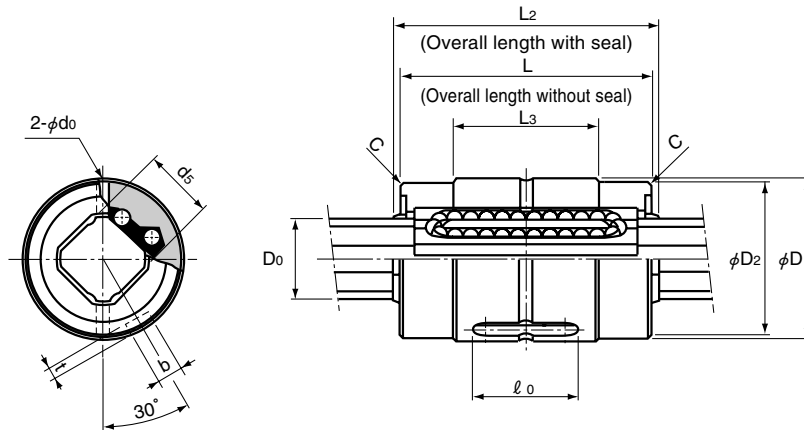

Models LBS6 and 8

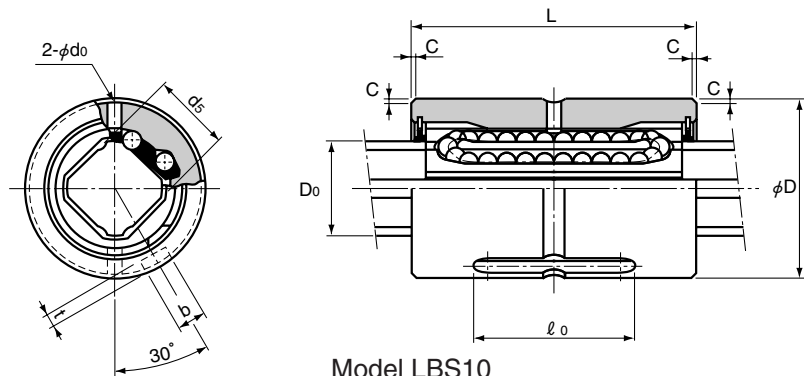

Model LBS10

Model No.	Spline nut dimensions											
	Outer diameter		Length		L ₂	L ₃	D ₂	Keyway dimensions			r	C
	D	Tolerance	L	Tolerance				b _{H8}	t _{+0.05/0}	l ₀		
(See Note 1) LBS 6	12	0	20	-0.2	20.8	11	11.5	2	0.8	10	—	0.3
(See Note 1) LBS 8	16	-0.011	25		26.4	14.5	15.5	2.5	1.2	12.5	—	0.3
LBS 10	19	0	30		—	—	—	3	1.5	17	—	0.3
LBS 15	23	-0.013	40	0	—	—	—	3.5	2	20	0.5	—
○ ● LBS 20	30	0	50		—	—	—	4	2.5	26	0.5	—
○ ● LBS 25	37		60		—	—	—	5	3	33	0.5	—
○ ● LBS 30	45		-0.016	70	—	—	—	7	4	41	1	—
○ ● LBS 40	60	0	90	-0.3	—	—	—	10	4.5	55	1	—
○ ● LBS 50	75	-0.019	100		—	—	—	15	5	60	1.5	—
○ ● LBS 70	100	0	110		—	—	—	18	6	68	2	—
○ ● LBS 85	120	-0.022	140	0	—	—	—	20	7	80	2.5	—
○ ● LBS100	140	-0.025	160		-0.4	—	—	—	28	9	93	3

Note 1: Models LBS6 and 8 are end cap types.

With models LBS6 and 8, do not give a shock to the end cap.

Note 2: A high-temperature type is not available for miniature Ball Splines.

○: For those models, high-temperature types (metal retainer, service temperature: up to 100°C) are available.

(Example) LBS20 A CL+500L H

Symbol for high-temperature type

●: Those models can be attached with a felt seal.

Ball Splines using metal retainers cannot be attached with a felt seal.

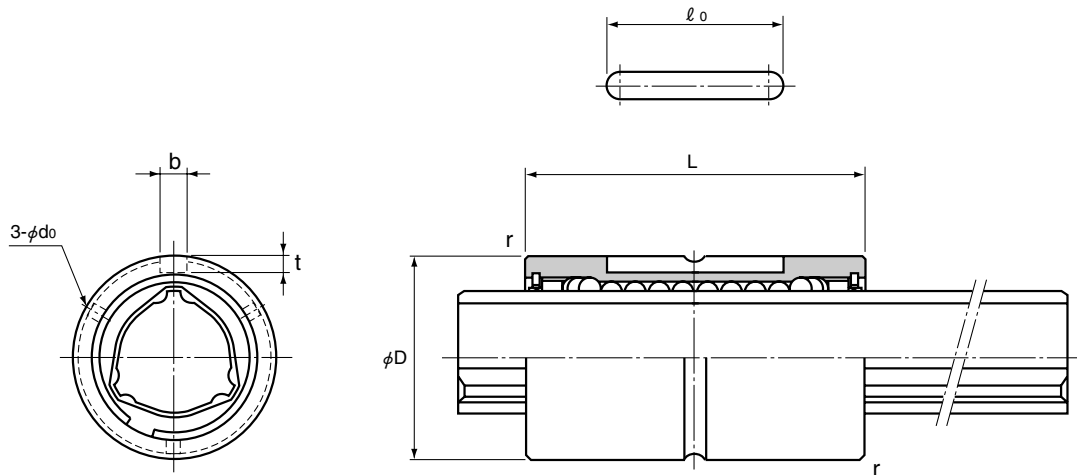

Model LBS15 or larger

Unit: mm

Greasing hole	Spline shaft outer diameter			Basic torque rating		Basic load rating (radial)		Static permissible moment		Mass	
	d_0	D_0	d_5	C_T [N-m]	C_{OT} [N-m]	C [kN]	C_0 [kN]	M_{A1} [N-m]	M_{A2} [N-m]	Spline nut [kg]	Spline shaft [kg/m]
1.2	6	5.3	1.53	2.41	0.637	0.785	2.2	19.4	0.0066	0.22	
1.2	8	7.3	4.07	6.16	1.18	1.42	5.1	39.6	0.0154	0.42	
1.5	10	8.3	7.02	10.4	1.62	1.96	8.1	67.6	0.0367	0.55	
2	—	—	30.4	74.5	4.4	8.4	25.4	185	0.06	1	
2	—	—	74.5	160	7.8	14.9	60.2	408	0.14	1.8	
2	—	—	154	307	13	23.5	118	760	0.25	2.7	
3	—	—	273	538	19.3	33.8	203	1270	0.44	3.8	
3	—	—	599	1140	31.9	53.4	387	2640	1	6.8	
4	—	—	1100	1940	46.6	73	594	4050	1.7	10.6	
4	—	—	2190	3800	66.4	102	895	6530	3.1	21.3	
5	—	—	3620	6360	90.5	141	2000	12600	5.5	32	
5	—	—	5190	12600	126	237	3460	20600	9.5	45	

Note 3: M_{A1} indicates the permissible moment value in the axial direction when one spline nut is used.

M_{A2} indicates the permissible moment value in the axial direction when two spline nuts are used.

(Using a single LBS unit is not stable in accuracy. We recommend using a single LBST unit or two units of model LBS in close contact with each other.)

Note 4: For details on the maximum lengths of ball spline shafts by accuracy, please see page 8.

Example of model number coding

2 LBS40 UU CL +1000L P K

Model number	Symbol for clearance in the rotational direction (see page 6)	Accuracy symbol (see page 7)	Symbol for standard hollow spline shaft (no symbol: solid spline shaft)
Number of spline nuts on one shaft (no symbol for one spline nut)	Overall spline shaft length (in mm)		
	Dust prevention accessory symbol No symbol: without seal UU: rubber seal attached on both ends of spline nut U: rubber seal attached on either end of spline nut DD: felt seal attached on both ends of spline nut D: felt seal attached on either end of spline nut		

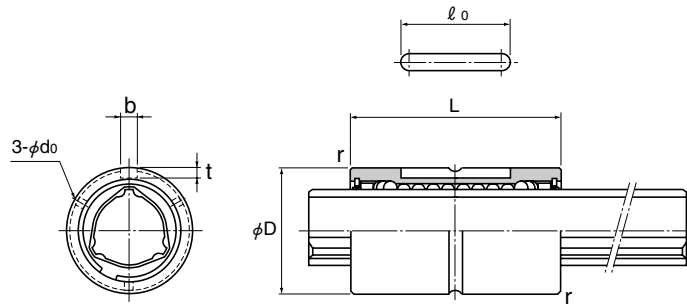

Model LBST

Dimensional Table for Model LBST – Heavy Load Type



Unit: mm

Model No.	Spline nut dimensions								Greasing hole d ₀
	Outer diameter		Length		Keyway dimensions			r	
	D	Tolerance	L	Tolerance	b H8	t +0.05 0	ℓ ₀		
○ ● LBST 20	30	0 -0.016	60	0 -0.2	4	2.5	26	0.5	2
○ ● LBST 25	37		70		5	3	33	0.5	2
○ ● LBST 30	45	0 -0.019	80	0 -0.3	7	4	41	1	3
○ ● LBST 40	60		100		10	4.5	55	1	3
○ ● LBST 50	75	0 -0.022	112	0 -0.4	15	5	60	1.5	4
○ LBST 60	90		127		18	6	68	1.5	4
○ ● LBST 70	100	0 -0.025	135	0 -0.5	18	6	68	2	4
○ ● LBST 85	120		155		20	7	80	2.5	5
○ ● LBST 100	140	0 -0.029	175	0 -0.5	28	9	93	3	5
○ LBST 120	160		200		28	9	123	3.5	6
○ LBST 150	205		250		32	10	157	3.5	6

Model No.	Basic torque rating		Basic load rating (radial)		Static permissible moment		Mass	
	C _T [N-m]	C _{OT} [N-m]	C [kN]	C ₀ [kN]	 M _{A1} (See Note 2) [N-m]	 M _{A2} (See Note 2) [N-m]	Spline nut [kg]	Spline shaft [kg/m]
○ ● LBST 20	90.2	213	9.4	20.1	103	632	0.17	1.8
○ ● LBST 25	176	381	14.9	28.7	171	1060	0.29	2.7
○ ● LBST 30	312	657	22.5	41.4	295	1740	0.5	3.8
○ ● LBST 40	696	1420	37.1	66.9	586	3540	1.1	6.8
○ ● LBST 50	1290	2500	55.1	94.1	941	5610	1.9	10.6
○ LBST 60	1870	3830	66.2	121	1300	8280	3.3	15.6
○ ● LBST 70	3000	6090	90.8	164	2080	11800	3.8	21.3
○ ● LBST 85	4740	9550	119	213	3180	17300	6.1	32
○ ● LBST 100	6460	14400	137	271	4410	25400	10.4	45
○ LBST 120	8380	19400	148	306	5490	32400	12.9	69.5
○ LBST 150	13900	32200	196	405	8060	55400	28	116.6

Note 1: ○: For those models, high-temperature types (metal retainer, service temperature: up to 100°C) are available.
(Example) LBST25 A CM+400L H

- : Symbol for high-temperature type
- : Those models can be attached with a felt seal.
Ball Splines using metal retainers cannot be attached with a felt seal.

Note 2: M_{A1} indicates the permissible moment value in the axial direction when one spline nut is used.

M_{A2} indicates the permissible moment value in the axial direction when two spline nuts are used.

Note 3: For details on the maximum lengths of ball spline shafts by accuracy, please see page 8.

Example of model number coding

2 LBST50 UU CM +800L H K

Model number
Number of spline nuts on one shaft (no symbol for one spline nut)

Symbol for clearance in the rotational direction (see page 6)

Accuracy symbol (see page 7)

Overall spline shaft length (in mm)

Symbol for standard hollow spline shaft (no symbol: solid spline shaft)

Dust prevention accessory symbol No symbol: without seal UU: rubber seal attached on both ends of spline nut

U: rubber seal attached on either end of spline nut DD: felt seal attached on both ends of spline nut

D: felt seal attached on either end of spline nut

Model LBF

Dimensional Table for Model LBF – Medium Load Type

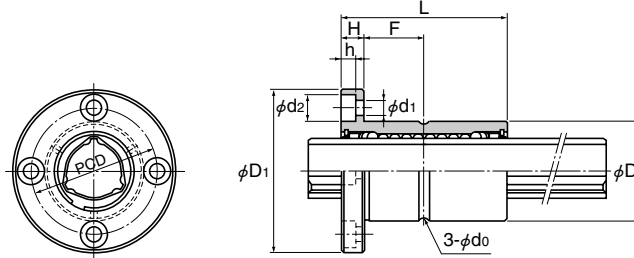

Unit: mm

Model No.	Spline nut dimensions									
	Outer diameter		Length		Flange diameter		H	F	Greasing hole d ₀	PCD
	D	Tolerance	L	Tolerance	D ₁	Tolerance				
LBF 15	23	$0_{-0.013}$	40	0	43	0 -0.2	7	13	2	32
○ ● LBF 20	30	-0.016	50	-0.2	49		7	18	2	38
○ ● LBF 25	37		60		60		9	21	2	47
○ ● LBF 30	45	0 -0.019	70	0 -0.3	70	10	25	3	54	
○ ● LBF 40	57		90		90	14	31	3	70	
○ ● LBF 50	70		100		108	16	34	4	86	
○ ● LBF 60	85	0 -0.022	127	-0.3	124	0	18	45.5	4	102
○ ● LBF 70	95		110		142	20	35	4	117	
○ ● LBF 85	115		140		168	22	48	5	138	
○ ● LBF 100	135	$0_{-0.025}$	160	-0.4	195	$0_{-0.4}$	25	55	5	162

Model No.	Spline nut dimensions	Basic torque rating		Basic load rating (radial)		Static permissible moment		Mass	
	Mounting hole d ₁ ×d ₂ ×h	C _T [N-m]	C _{OT} [N-m]	C [kN]	C ₀ [kN]	M _{A1} [N-m]	M _{A2} [N-m]	Spline nut [kg]	Spline shaft [kg/m]
	LBF 15	4.5×8×4.4	30.4	74.5	4.4	8.4	25.4	185	0.11
○ ● LBF 20	4.5×8×4.4	74.5	160	7.8	14.9	60.2	408	0.2	1.8
○ ● LBF 25	5.5×9.5×5.4	154	307	13	23.5	118	760	0.36	2.7
○ ● LBF 30	6.6×11×6.5	273	538	19.3	33.8	203	1270	0.6	3.8
○ ● LBF 40	9×14×8.6	599	1140	31.9	53.4	387	2640	1.2	6.8
○ ● LBF 50	11×17.5×11	1100	1940	46.6	73	594	4050	1.9	10.6
○ ● LBF 60	11×17.5×11	1870	3830	66.2	121	1300	8280	3.5	15.6
○ ● LBF 70	14×20×13	2190	3800	66.4	102	895	6530	3.6	21.3
○ ● LBF 85	16×23×15.2	3620	6360	90.5	141	2000	12600	6.2	32
○ ● LBF 100	18×26×17.5	5910	12600	126	237	3460	20600	11	45

Note 1: ○: For those models, high-temperature types (metal retainer, service temperature: up to 100°C) are available.
(Example) LBF20 A CL+500L H

- : Those models can be attached with a felt seal.
Ball Splines using metal retainers cannot be attached with a felt seal.

Note 2: M_{A1} indicates the permissible moment value in the axial direction when one spline nut is used.

M_{A2} indicates the permissible moment value in the axial direction when two spline nuts are used.

(Using a single spline nut is not stable in accuracy. We recommend using two spline nuts in close contact with each other.)

Note 3: For details on the maximum lengths of ball spline shafts by accuracy, please see page 8.

Example of model number coding

2 LBF20 DD CL +900L P K

Model number	Symbol for clearance in the rotational direction (see page 6)	Accuracy symbol (see page 7)	Symbol for standard hollow spline shaft (no symbol: solid spline shaft)
Number of spline nuts on one shaft (no symbol for one spline nut)	Overall spline shaft length (in mm)	Dust prevention accessory symbol No symbol: without seal UU: rubber seal attached on both ends of spline nut U: rubber seal attached on either end of spline nut DD: felt seal attached on both ends of spline nut D: felt seal attached on either end of spline nut	

Model LBR

Dimensional Table for Model LBR

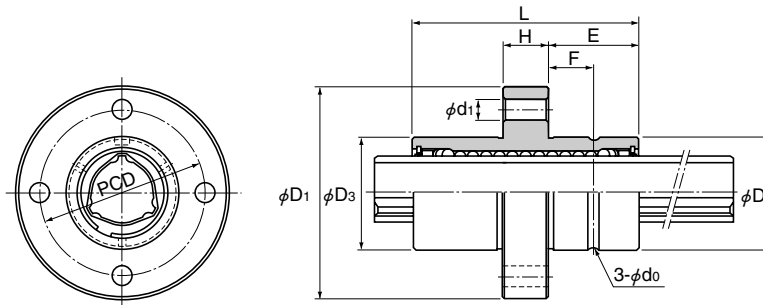

Unit: mm

Model No.	Spline nut dimensions								
	Outer diameter		Outer diameter	Length		Flange diameter	H	E	PCD
	D	Tolerance	D ₃	L	Tolerance	D ₁			
LBR 15	25	$0_{-0.013}$	25.35	40	0	45.4	9	15.5	34
○ ● LBR 20	30	0	30.35	60	-0.2	56.4	12	24	44
○ ● LBR 25	40		40.35	70		70.4	14	28	54
○ ● LBR 30	45		45.4	80		75.4	16	32	61
○ ● LBR 40	60	0	60.4	100	0	96.4	18	41	78
○ ● LBR 50	75	-0.019	75.4	112		112.4	20	46	94
○ LBR 60	90	0	90.5	127		134.5	22	52.5	112
○ ● LBR 70	95		95.6	135	140.6	24	55.5	117	
○ ● LBR 85	120		-0.022	120.6	155	170.6	26	64.5	146
○ ● LBR 100	140	$0_{-0.025}$	140.6	175	-0.4	198.6	34	70.5	170

Model No.	Spline nut dimensions			Basic torque rating		Basic load rating (radial)		Static permissible moment		Mass	
	Mounting hole	F	Greasing hole	C _T [N-m]	C _{OT} [N-m]	C [kN]	C ₀ [kN]	M _{A1} (See Note 2) [N-m]	M _{A2} (See Note 2) [N-m]	Spline nut [kg]	Spline shaft [kg/m]
	d ₁		d ₀								
LBR 15	4.5	7.5	2	30.4	74.5	4.4	8.4	25.4	185	0.14	1
○ ● LBR 20	5.5	12	2	90.2	213	9.4	20.1	103	632	0.33	1.8
○ ● LBR 25	5.5	14	2	176	381	14.9	28.7	171	1060	0.54	2.7
○ ● LBR 30	6.6	16	3	312	657	22.5	41.4	295	1740	0.9	3.8
○ ● LBR 40	9	20.5	3	696	1420	37.1	66.9	586	3540	1.7	6.8
○ ● LBR 50	11	23	4	1290	2500	55.1	94.1	941	5610	2.7	10.6
○ LBR 60	11	26	4	1870	3830	66.2	121	1300	8280	3.7	15.6
○ ● LBR 70	14	27	4	3000	6090	90.8	164	2080	11800	6	21.3
○ ● LBR 85	16	32	5	4740	9550	119	213	3180	17300	8.3	32
○ ● LBR 100	18	35	5	6460	14400	137	271	4410	25400	14.2	45

Note 1: ○: For those models, high-temperature types (metal retainer, service temperature: up to 100°C) are available.

(Example) LBR40 A CM+600L H

Symbol for high-temperature type

●: Those models can be attached with a felt seal.

Ball Splines using metal retainers cannot be attached with a felt seal.

Note 2: M_{A1} indicates the permissible moment value in the axial direction when one spline nut is used.

M_{A2} indicates the permissible moment value in the axial direction when two spline nuts are used.

Note 3: For details on the maximum lengths of ball spline shafts by accuracy, please see page 8.

Example of model number coding

2 LBR30 UU CM +700L H K

Model number	Symbol for clearance in the rotational direction (see page 6)	Accuracy symbol (see page 7)	Symbol for standard hollow spline shaft (no symbol: solid spline shaft)
Number of spline nuts on one shaft (no symbol for one spline nut)	Overall spline shaft length (in mm)		
	Dust prevention accessory symbol	No symbol: without seal	UU: rubber seal attached on both ends of spline nut
	U: rubber seal attached on either end of spline nut	DD: felt seal attached on both ends of spline nut	D: felt seal attached on either end of spline nut

Model LBH

Dimensional Table for Model LBH

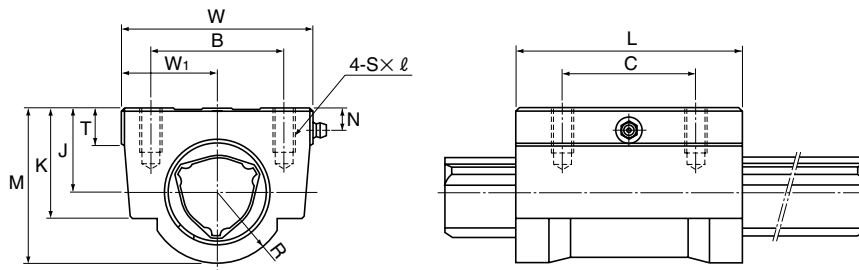

Unit: mm

Model No.	Spline nut dimensions									
	Height	Width	Length				J	W ₁	T	K
	M	W	L	B	C	S×l	±0.15	±0.15		
○ LBH 15	29	34	43	26	26	M4×10	15	17	6	20
○● LBH 20	38	48	62	35	35	M6×12	20	24	7	26
○● LBH 25	47.5	60	73	40	40	M8×16	25	30	8	33
○● LBH 30	57	70	83	50	50	M8×16	30	35	10	39
○● LBH 40	70	86	102	60	60	M10×20	38	43	15	50
○● LBH 50	88	100	115	75	75	M12×25	48	50	18	63

Model No.	Spline nut dimensions			Basic torque rating		Basic load rating (radial)		Static permissible moment	Mass	
	R	N	Grease nipple	C _T [N-m]	C _{OT} [N-m]	C [kN]	C ₀ [kN]	M _A (See Note 2) [N-m]	Spline nut [kg]	Spline shaft [kg/m]
○ LBH 15	14	5	φ 4 drive nipple	30.4	74.5	4.4	8.4	25.4	0.23	1
○● LBH 20	18	7	A-M6F	90.2	213	9.4	20.1	103	0.58	1.8
○● LBH 25	22	6	A-M6F	176	381	14.9	28.7	171	1.1	2.7
○● LBH 30	26	8	A-M6F	312	657	22.5	41.4	295	1.73	3.8
○● LBH 40	32	10	A-M6F	696	1420	37.1	66.9	586	3.18	6.8
○● LBH 50	40	13.5	A-PT1/8	1290	2500	55.1	94.1	941	5.1	10.6

Note 1: ○: For those models, high-temperature types (metal retainer, service temperature: up to 100°C) are available.
(Example) LBH30 A CM+600L H

- : Symbol for high-temperature type
- : Those models can be attached with a felt seal.
Ball Splines using metal retainers cannot be attached with a felt seal.

Note 2: M_A indicates the permissible moment value in the axial direction when a single spline nut is used.

Note 3: For details on the maximum lengths of ball spline shafts by accuracy, please see page 8.

Example of model number coding

2 LBH40 UU CL +700L P K

Model number	Symbol for clearance in the rotational direction (see page 6)	Accuracy symbol (see page 7)	Symbol for standard hollow spline shaft (no symbol: solid spline shaft)
Number of spline nuts on one shaft (no symbol for one spline nut)	Overall spline shaft length (in mm)	Dust prevention accessory symbol No symbol: without seal UU: rubber seal attached on both ends of spline nut U: rubber seal attached on either end of spline nut DD: felt seal attached on both ends of spline nut D: felt seal attached on either end of spline nut	

Model LTR-A

Dimensional Table for Models LTR-A

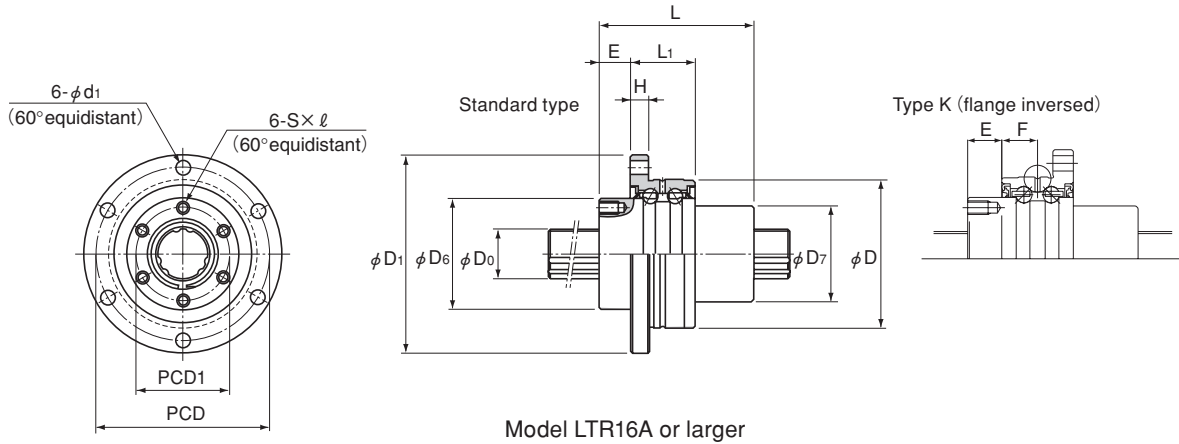

Model No.	Spline nut dimensions													
	Outer diameter		Length L	Flange diameter D ₁	D ₆ h7	D ₇	H	L ₁	E	Type K E	Oil hole position F	E ₁	PCD	PCD1
	D	Tolerance												
LTR 8A	32	-0.009 -0.025	25	44	24	16	3	10.5	6	8.5	4	3	38	19
LTR 10A	36		33	48	28	21	3	10.5	9	11.5	4	—	42	23
LTR 16A	48		50	64	36	31	6	21	10	10	10.5	—	56	30
LTR 20A	56	-0.010 -0.029	63	72	43.5	35	6	21	12	12	10.5	—	64	36
LTR 25A	66		71	86	52	42	7	25	13	13	12.5	—	75	44
LTR 32A	78		80	103	63	52	8	25	17	17	12.5	—	89	54
LTR 40A	100	-0.012 -0.034	100	130	79.5	64	10	33	20	20	16.5	—	113	68

Example of model number coding

2	LTR32A	K	UU	ZZ	CL	+500L	P	K
Number of spline nuts on one shaft (no symbol for one spline nut)	Model number Flange orientation symbol No symbol: standard K: flange inverted	Spline nut dust prevention accessory symbol UU: rubber seal attached on both ends of spline nut	Support bearing dust prevention accessory symbol ZZ: rubber seal attached on both ends of support bearing Z: rubber seal attached on either end of support bearing	Symbol for clearance in the rotational direction (see page 6)	Overall spline shaft length (in mm)	Accuracy symbol (see page 7)	Symbol for standard hollow spline shaft (no symbol: solid spline shaft)	No symbol: without seal U: rubber seal attached on either end of spline nut

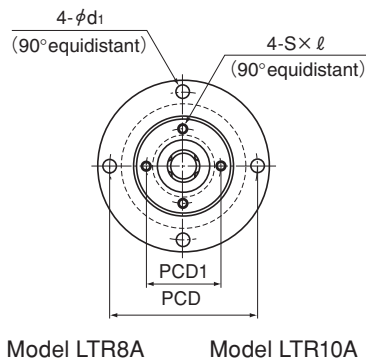

Model LTR8A

Model LTR10A

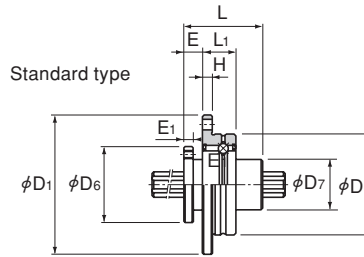

Model LTR8A

Type K (flange inverted)

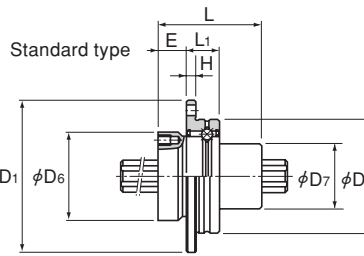
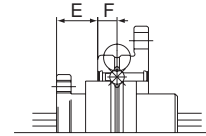

Model LTR10A

Type K (flange inverted)

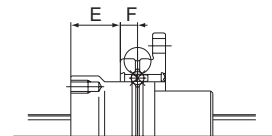

Unit: mm

S \times ℓ	d ₁	Spline shaft diameter D ₀ h7	No. of rows of balls	Basic torque rating		Basic load rating		Static permissible moment  M _A (See Note 1) [N-m]	Support bearing basic load rating		Mass	
				C _T [N-m]	C _{OT} [N-m]	C [kN]	C ₀ [kN]		C [kN]	C ₀ [kN]	Spline nut [kg]	Spline shaft [kg/m]
M2.6 \times 3	3.4	8	4	1.96	2.94	1.47	2.55	5.9	0.69	0.24	0.08	0.4
M3 \times 4	3.4	10	4	3.92	7.84	2.84	4.9	15.7	0.77	0.3	0.13	0.62
M4 \times 6	4.5	16	6	31.3	34.3	7.05	12.6	67.6	6.7	6.4	0.35	1.6
M5 \times 8	4.5	20	6	56.8	55.8	10.2	17.8	118	7.4	7.8	0.51	2.5
M5 \times 8	5.5	25	6	105	103	15.2	25.8	210	9.7	10.6	0.79	3.9
M6 \times 10	6.6	32	6	180	157	20.5	34	290	10.5	12.5	1.25	5.6
M6 \times 10	9	40	6	418	377	37.8	60.4	687	16.5	20.7	2.51	9.9

Note 1: M_A indicates the permissible moment value in the axial direction when a single spline nut is used.

Note 2: For details on the maximum lengths of ball spline shafts by accuracy, please see page 8.

Model LTR

Dimensional Table for Models LTR

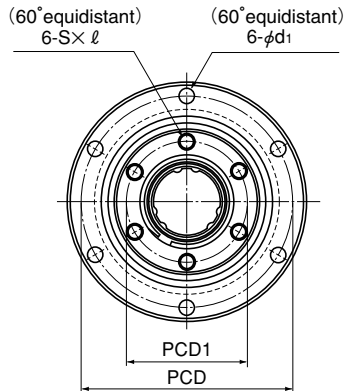

Model No.	Spline nut dimensions										
	Outer diameter		Length	Flange diameter	D_e h7	H	L_1	E	PCD	PCD1	$S \times l$
	D	Tolerance	L	D_1							
LTR 16	52	0 -0.007	50	68	39.5	5	37	10	60	32	M5×8
LTR 20	56		63	72	43.5	6	48	12	64	36	M5×8
LTR 25	62		71	78	53	6	55	13	70	45	M6×8
LTR 32	80	0 -0.008	80	105	65.5	9	60	17	91	55	M6×10
LTR 40	100		100	130	79.5	11	74	23	113	68	M6×10
LTR 50	120		125	156	99.5	12	97	25	136	85	M10×15
LTR 60	134	0 -0.009	140	170	115	12	112	25	150	100	M10×15

Example of model number coding

2	LTR50	K	UU	ZZ	CM	+1000L	H	K
Number of spline nuts on one shaft (no symbol for one spline nut)	Model number Flange orientation symbol No symbol: standard K: flange inversed	Spline nut dust prevention accessory symbol UU: rubber seal attached on both ends of spline nut	Support bearing dust prevention accessory symbol ZZ: rubber seal attached on both ends of support bearing	Symbol for clearance in the rotational direction (see page 6)	Accuracy symbol (see page 7)	Overall spline shaft length (in mm)	No symbol: without seal	Symbol for standard hollow spline shaft (no symbol: solid spline shaft)

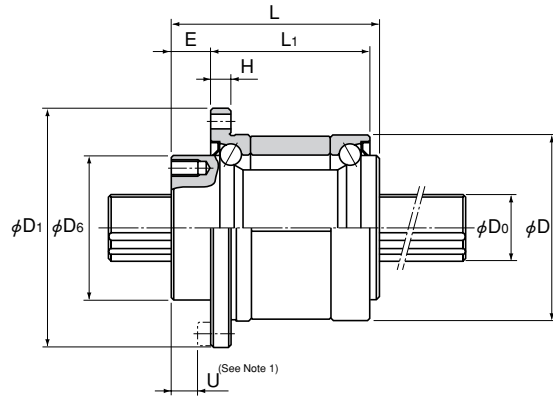

Unit: mm

d _i	U (See Note 1)	Spline shaft diameter		No. of rows of balls	Basic torque rating		Basic load rating		Static permissible moment M _A (See Note 2)	Support bearing basic load rating		Mass	
		D ₀ h7			C _T [N-m]	C _{0T} [N-m]	C [kN]	C ₀ [kN]		C [kN]	C ₀ [kN]	Spline nut [kg]	Spline shaft [kg/m]
4.5	5	16		6	31.4	34.3	7.06	12.6	67.6	12.7	11.8	0.51	1.6
4.5	7	20		6	56.9	55.9	10.2	17.8	118	16.3	15.5	0.7	2.5
4.5	8	25		6	105	103	15.2	25.8	210	17.6	18	0.93	3.9
6.6	10	32		6	180	157	20.5	34	290	20.1	24	1.8	5.6
9	13	40		6	419	377	37.8	60.5	687	37.2	42.5	3.9	9.9
11	13	50		6	842	769	60.9	94.5	1340	41.7	54.1	6.7	15.5
11	13	60		6	1220	1040	73.5	111.7	1600	53.1	68.4	8.8	22.3

Note 1: Dimension U represents the dimension from the head of the hexagon socket screw to the spline nut end.

Note 2: M_A indicates the permissible moment value in the axial direction when a single spline nut is used.

Note 3: For details on the maximum lengths of ball spline shafts by accuracy, please see page 8.