

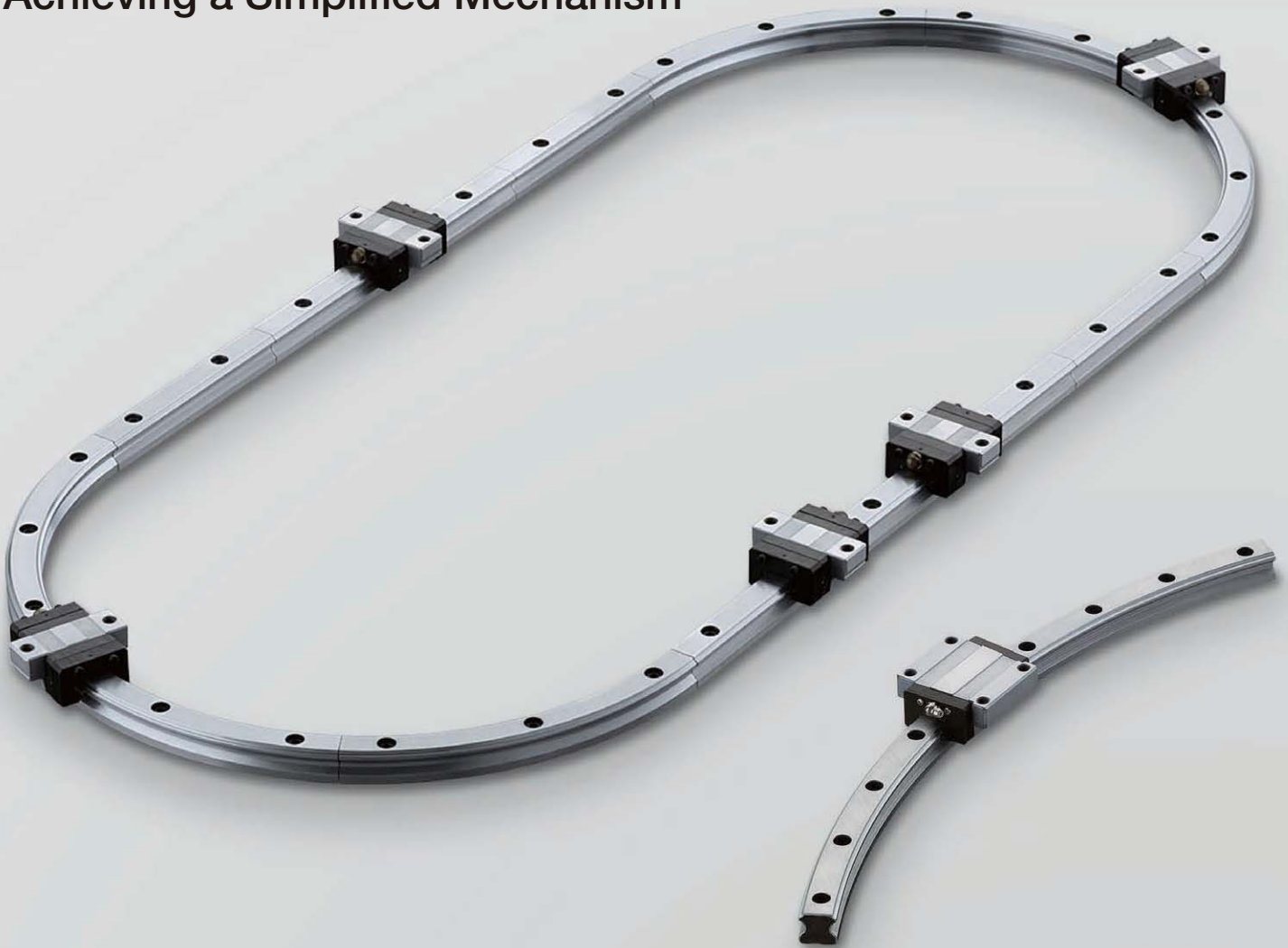

# LM Guide

## HCR/HMG

R Guide / Straight-Curved Guide  
Achieving a Simplified Mechanism



For details, visit THK at [www.thk.com](http://www.thk.com)

\*Product information is updated regularly on the THK website.

# HCR

## LM Guide R Guide Model

This product is suitable for the application require accurate arc movement.

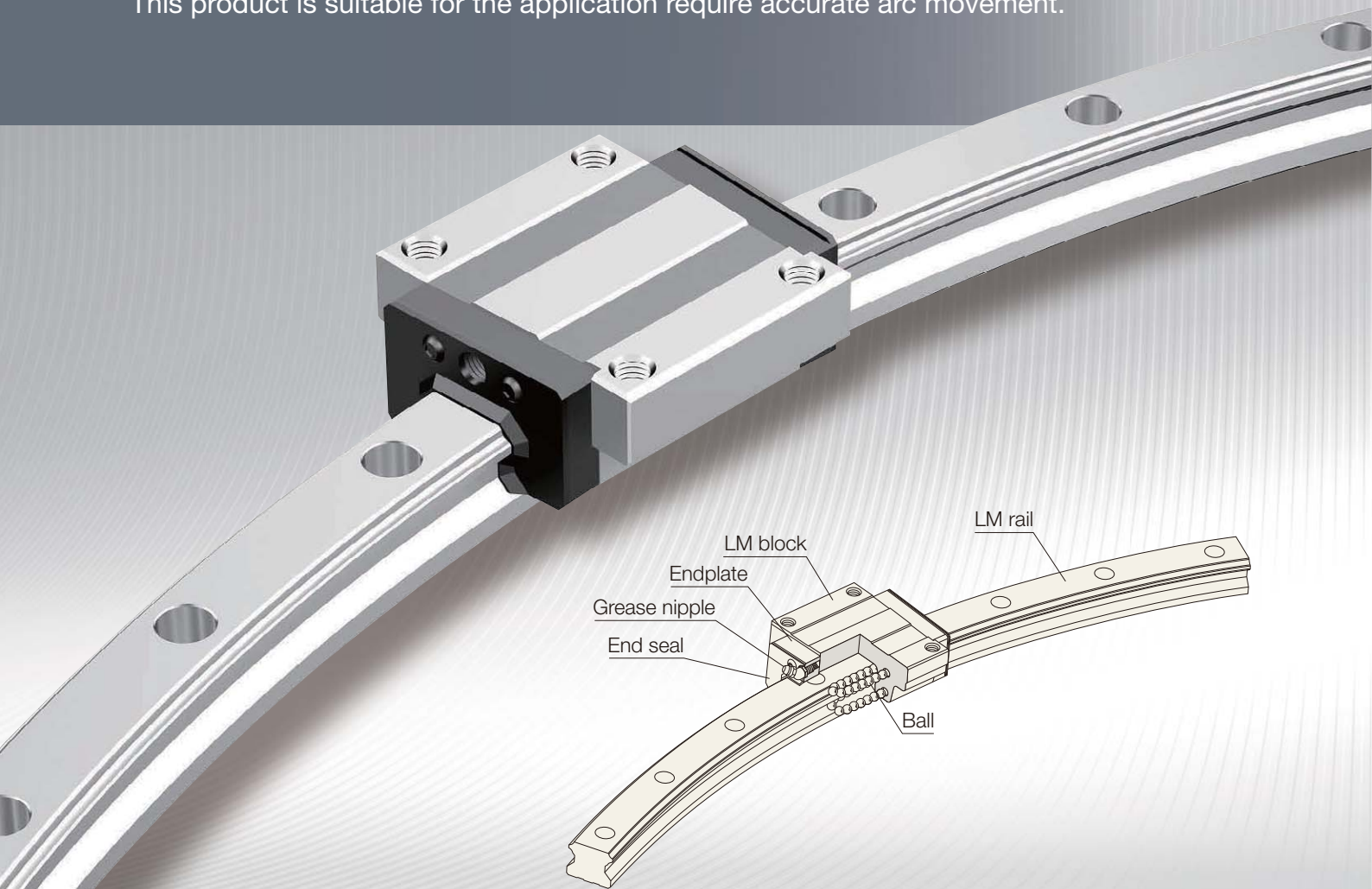

### Structure

Balls roll in four rows of raceways precision-ground on an LM rail and an LM block, and endplates incorporated in the LM block allow the balls to circulate to realize infinite motion.

If LM blocks are removed from LM rails, balls will fall, so do not remove LM blocks.

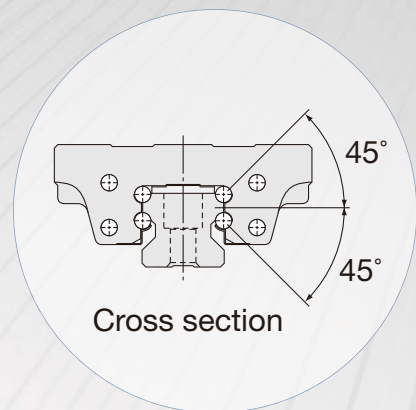

# Features

## 1 Highly Accurate Circular Motion

As the preload is available, high accurate circular motion and whirling motion without clearance can be realized easily. Design can be adjusted to the conditions as the number of LM blocks can be selected.

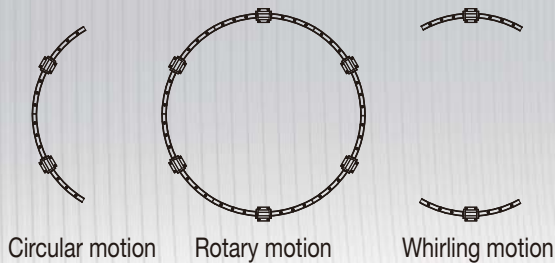

## 2 Easy Assembly/Transfer

By the error-absorbing capability, misalignment on the mounting surface can be absorbed so assembly is easy and high accurate circular motion are possible. In addition, rails are divided by circle, so the equipment can be reassembled easily.

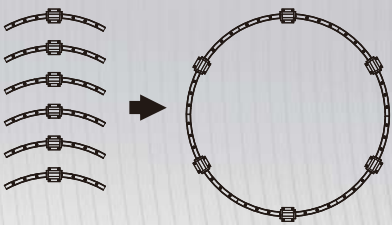

## 3 4-way Equal Load

Each row of balls is placed at a contact angle of 45° so that the rated loads applied to the LM block are uniform in the four directions (radial, reverse radial and lateral directions). Therefore, it can be used in any installation directions and used for a wide range of applications.

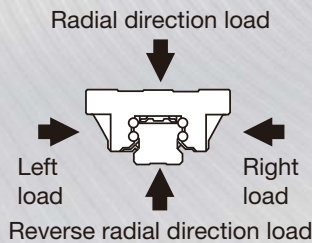

## 4 Self-aligning Capability

The self-aligning capability through face-to-face configuration of THK's unique circular-arc grooves (DF structure) enables a mounting error to be absorbed even under a preload, thus to achieve highly accurate, smooth circular motion and whirling motion.

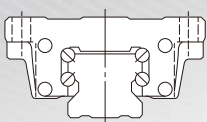

LM guide (DF structure) of the four-row circular-arc groove, two-point contact structure

## ● Selecting a Preload

Model HCR includes two radial clearance (preload).

The radial clearance greatly affects the running accuracy, load carrying capacity and rigidity of the LM Guide, it is important to select an appropriate radial clearance according to the application.

An appropriate radial clearance reduces vibrations and impact generated during the operation of the device and favorably affects the service life and the accuracy.

### Types of Radial Clearance

Radial Clearance (Preload)	Radial clearance symbol	Usage conditions
Normal clearance	No symbol	- Parts which you want to move lightly
Clearance C1 (Light preload)	C1	- Parts where there are few vibration or impact - Parts used in a single-rail configuration - Parts which require light load and high accuracy

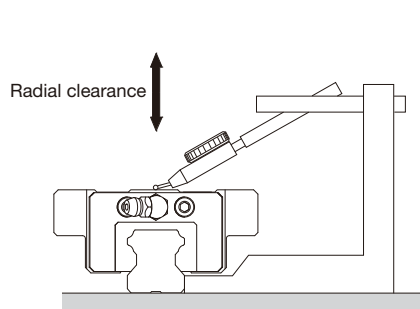

Radial clearance standard Unit:  $\mu\text{m}$

Model No.	Radial clearance standard	
	Normal clearance	Clearance C1
HCR	12	-3 to +3
	15	-4 to +2
	25	-6 to +3
	35	-8 to +4
	45	-10 to +5
65	-14 to +7	

## ● Selecting the Accuracy Grade

Model HCR has two accuracy grades.

The accuracy standard is specified in terms of running parallelism, dimensional tolerance for height, and height difference between a pair when 2 or more LM blocks are used on one rail or when 2 or more rails are mounted on the same plane.

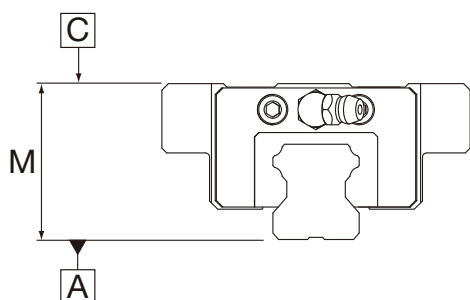

Running Parallelism Unit:  $\mu\text{m}$

LM rail length (mm)		Running Parallelism Values	
Above	Or Less	Normal grade	High-accuracy grade
—	125	30	15
125	200	37	18
200	250	40	20
250	315	44	22
315	400	49	24
400	500	53	26
500	630	58	29
630	800	64	32
800	1000	70	35
1000	1250	77	38
1250	1600	84	42
1600	2000	92	46

Accuracy Standards

Unit: mm

Model No.	Accuracy Grade	Normal grade	High-accuracy grade
	Item	No symbol	H
12	Dimensional tolerance in height M	$\pm 0.2$	$\pm 0.2$
15	Difference in height M	0.05	0.03
25	Running parallelism of surface C against surface A	$\Delta C$ (according to the running parallelism table above)	
35			
45	Dimensional tolerance in height M	$\pm 0.2$	$\pm 0.2$
	Difference in height M	0.06	0.04
	65	Running parallelism of surface C against surface A	$\Delta C$ (according to the running parallelism table above)



## ●Optional Part

The following parts are available as optional parts of model HCR.  
 Select from them according to the conditions and environment.  
 For details of each optional product, see P.10, 11.

In normal environments (atmosphere and normal temperature) consider attaching the end seal and side seal (option symbol: SS). (Option symbol of HCR12: UU)

### Model HCR Optional Parts Correspondence List

●: Compatible

HCR		Options Symbol	Size					
			12	15	25	35	45	65
Contamination protection accessories	End seal	UU	●	●	●	●	●	●
	End seal+ Side seal	SS	—	●	●	●	●	●
	Double seals+ Side seal	DD	—	●	●	●	●	●
	End seal+ Side seal+ Metal Scraper	ZZ	—	● *	●	●	●	●
	Double seals+ Side seal+ Metal Scraper	KK	—	● *	●	●	●	●
	Low resistance end seal	LL	—	●	●	●	●	●
	Low resistance end seal+ side seal	RR	—	●	●	●	●	●
	Dedicated cap C	—	—	●	●	●	●	●
	Dedicated cap GC	—	—	—	●	●	●	●

\*The model HCR15 ZZ and KK types do not support grease nipples.

## Maximum Resistance Value of Seal

This shows the maximum resistance value of seals per LM block with a lubricant applied.

Maximum resistance value of UU seal

Unit: N

Model No.		Seal symbol	Seal Maximum Resistance Value
HCR	12	UU	1.2
	15		2.0
	25		3.9
	35		11.8
	45		19.6
	65		34.3

# HCR-A (12-65)

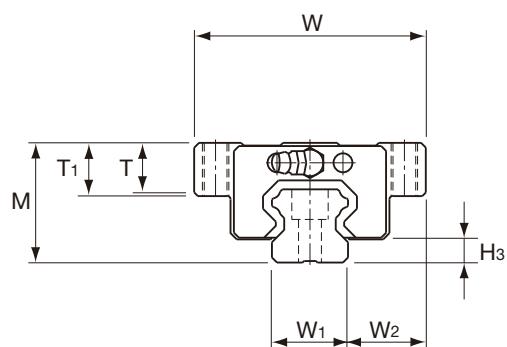
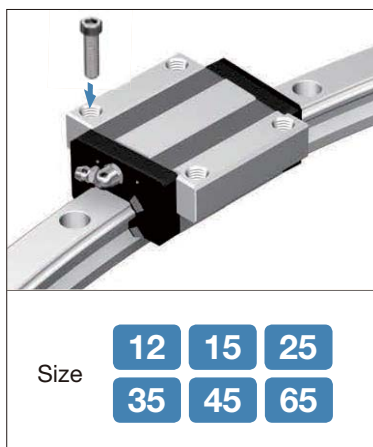

Model No.	Outer dimensions			LM block dimensions									Grease nipple	H <sub>3</sub>
	Height	Width	Length	B	C	S	L <sub>1</sub>	T	T <sub>1</sub>	N	E			
	M	W	L											
HCR 12A+60/100R	18	39	44.6	32	18	M4	30.5	4.5	5	3.4	3.5	PB107	3.1	
HCR 15A+60/150R HCR 15A+60/300R HCR 15A+60/400R	24	47	54.5 55.5 55.8	38	24 28 28	M5	38.8	10.3	11	4.5	5.5	PB1021B	4.8	
HCR 25A+60/500R HCR 25A+60/750R HCR 25A+60/1000R	36	70	81.6 82.3 82.5	57	45	M8	59.5	14.9	16	6	12	B-M6F	7	
HCR 35A+60/600R HCR 35A+60/800R HCR 35A+60/1000R HCR 35A+60/1300R	48	100	107.2 107.5 108.2 108.5	82	58	M10	80.4	19.9	21	8	12	B-M6F	8.5	
HCR 45A+60/800R HCR 45A+60/1000R HCR 45A+60/1200R HCR 45A+60/1600R	60	120	136.7 137.3 137.3 138	100	70	M12	98	23.9	25	10	16	B-R1/8 (B-PT1/8)	11.5	
HCR 65A+60/1000R HCR 65A+60/1500R HCR 65A+45/2000R HCR 65A+45/2500R HCR 65A+30/3000R	90	170	193.8 195.4 195.9 196.5 196.5	142	106	M16	147	34.9	37	19	16	B-R1/8 (B-PT1/8)	15	

## Model number coding

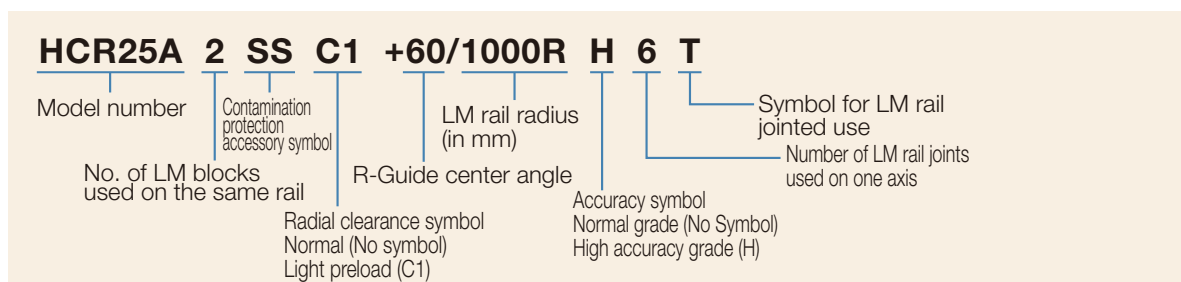

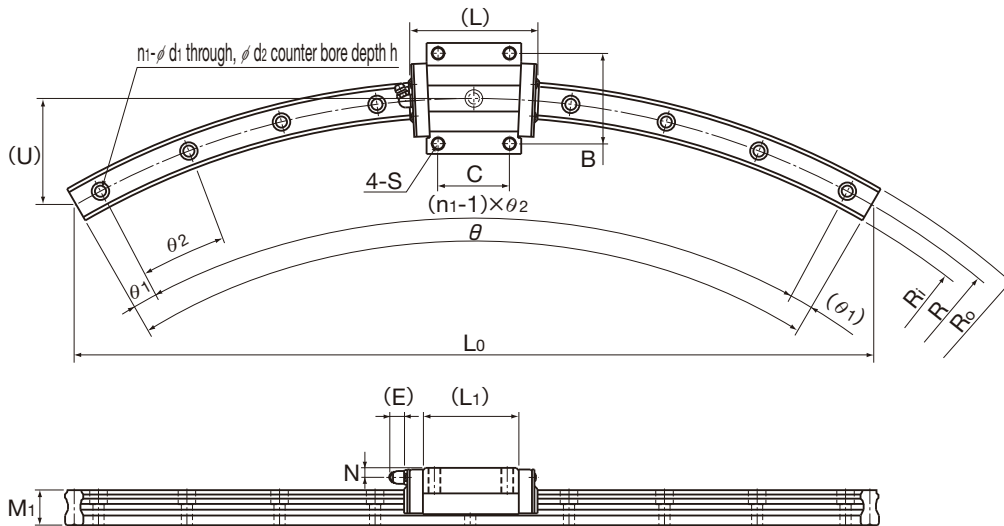

Unit: mm

	LM rail dimensions													Basic load rating		Static permissible moment kN-m*					Mass					
	R	Ro	Ri	L0	U	Width		Height	d1xd2xh	n1	θ°	θ1°	θ2°	C	Co	MA		MB		MC	LM block	LM rail				
						W1	W2									1 block	Double blocks	1 block	Double blocks				1 block	kg	kg/m	
	100	106	94	100	13.4	12	13.5	11	3.5x6x5	3	60	7	23	4.7	8.53	0.0409	0.228	0.0409	0.228	0.0445	0.08	0.83				
	150	157.5	142.5	150	20.1	15	16	15	4.5x7.5x5.3	3	60	7	23	6.66	10.8	0.0805	0.457	0.0805	0.457	0.0844	0.2	1.5				
	300	307.5	292.5	300	40					5		6	12	8.33	13.5								6	12	8.33	13.5
	400	407.5	392.5	400	54					7		3	9	8.33	13.5											
	500	511.5	488.5	500	67	23	23.5	22	7x11x9	9	60	2	7	19.9	34.4	0.307	1.71	0.307	1.71	0.344	0.59	3.3				
	750	761.5	738.5	750	100					12		2.5	5										5	5	5	4
	1000	1011.5	988.5	1000	134					15		2	4													
	600	617	583	600	80	34	33	29	9x14x12	7	60	3	9	37.3	61.1	0.782	3.93	0.782	3.93	0.905	1.6	6.6				
	800	817	783	800	107					11		2.5	5.5										5	5	5	3.5
	1000	1017	983	1000	134					12		2.5	5										5	5	2	3.5
	1300	1317	1283	1300	174					17		2	3.5													
	800	822.5	777.5	800	107	45	37.5	38	14x20x17	8	60	2	8	60	95.6	1.42	7.92	1.42	7.92	1.83	2.8	11.0				
	1000	1022.5	977.5	1000	134					10		3	6										6	6	4	
	1200	1222.5	1177.5	1200	161					12		2.5	5										5	5	2	4
	1600	1622.5	1577.5	1600	214					15		2	4													
	1000	1031.5	968.5	1000	134	63	53.5	53	18x26x22	8	60	2	8	141	215	4.8	23.5	4.8	23.5	5.82	8.5	22.5				
	1500	1531.5	1468.5	1500	201					10		3	6										6	6	4	
	2000	2031.5	1968.5	1531	152					12		45	0.5										4	4	3.5	
	2500	2531.5	2468.5	1913	190					13		45	1.5										3.5	3.5	3	
	3000	3031.5	2968.5	1553	102					10		30	1.5										3	3	3	

Note) LM rail radiuses other than the radiuses in the above table are also available. Contact THK for details.

The R-Guide center angles in the table are maximum manufacturing angles. To obtain angles greater than them, rails must be additionally connected. Contact THK for details.

Static permissible moment\*: 1 block: static permissible moment value with 1 LM block

Double blocks: static permissible moment value with 2 blocks closely contacting with each other

\*Lubrication

Lithium soap base grease No. 2 (AFB-LF grease) is contained in model HCR as standard.

If you want any other grease or any types without grease, contact THK.

# LM Block Dimensions with Optional Parts

## ●Dimensions with Contamination Protection Accessories

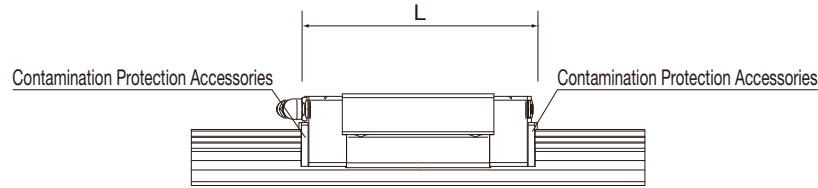

Unit: mm

Model No.		L						
		UU	SS	DD	ZZ	KK	LL	RR
HCR	12A+60/100R	44.6	—	—	—	—	—	—
	15A+60/150R	54.5	54.5	59.7	—	—	54.5	54.5
	15A+60/300R	55.5	55.5	60.7	57.1*	62.3*	55.5	55.5
	15A+60/400R	55.8	55.8	61	57.3*	62.5*	55.8	55.8
	25A+60/500R	81.6	81.6	89.2	85.5	93.1	81.6	81.6
	25A+60/750R	82.3	82.3	89.9	86	93.6	82.3	82.3
	25A+60/1000R	82.5	82.5	90.1	86.2	93.8	82.5	82.5
	35A+60/600R	107.2	107.2	114.8	111.2	118.8	107.2	107.2
	35A+60/800R	107.5	107.5	115.1	111.5	119.1	107.5	107.5
	35A+60/1000R	108.2	108.2	115.8	112	119.6	108.2	108.2
	35A+60/1300R	108.5	108.5	116.1	112.3	119.8	108.5	108.5
	45A+60/800R	136.7	136.7	143.9	142.1	149.2	136.7	136.7
	45A+60/1000R	137.3	137.3	144.5	142.7	149.9	137.3	137.3
	45A+60/1200R	137.3	137.3	144.5	142.7	149.9	137.3	137.3
	45A+60/1600R	138	138	145.2	143.3	150.5	138	138
	65A+60/1000R	193.8	193.8	201	199.4	206.6	193.8	193.8
	65A+60/1500R	195.4	195.4	202.6	200.8	208	195.4	195.4
	65A+60/2000R	195.9	195.9	203.1	201.3	208.5	195.9	195.9
65A+60/2500R	196.5	196.5	203.7	201.8	209	196.5	196.5	
65A+60/3000R	196.5	196.5	203.7	201.8	209	196.5	196.5	

\*The model HCR15 ZZ and KK types do not support grease nipples.

## ●Calculating the Static Safety Factor

In a system subject to frequent starts and stops, placed under cutting forces or under a large moment caused by an overhang load, an excessively large load may apply to the LM Guide.

When selecting a model number, make sure that the desired model is capable of receiving the required maximum load (whether stationary or in motion) and calculate the static safety factor.

When the radial load is large	$\frac{f_H \cdot f_T \cdot f_C \cdot C_0}{P_R} \geq f_s$
When the reverse radial load is large	$\frac{f_H \cdot f_T \cdot f_C \cdot C_{0L}}{P_L} \geq f_s$
When the lateral loads are large	$\frac{f_H \cdot f_T \cdot f_C \cdot C_{0T}}{P_T} \geq f_s$

$f_s$  : Static safety factor

$C_0$  : Basic static load rating (radial direction) (N)

$C_{0L}$  : Basic static load rating (reverse radial direction) (N)

$C_{0T}$  : Basic static load rating (lateral direction) (N)

$P_R$  : Calculated load (radial direction) (N)

$P_L$  : Calculated load (reverse radial direction) (N)

$P_T$  : Calculated load (lateral direction) (N)

$f_H$  : Hardness factor

$f_T$  : Temperature factor

$f_C$  : Contact factor

### Reference Values of Static Safety Factor ( $f_s$ )

Machine using the LM system	Load conditions	Lower limit of $f_s$
General industrial machinery	Without vibration or impact	1.0 to 3.5
	With vibration or impact	2.0 to 5.0
Machine tool	Without vibration or impact	1.0 to 4.0
	With vibration or impact	2.5 to 7.0



# ● Calculating the Nominal Life

The service life of an LM Guide is subject to variations even under the same operational conditions.

Therefore, it is necessary to use the nominal life defined below as a reference value for obtaining the service life of the LM Guide.

The nominal life (L) means the total travel distance that 90% of a group of units of the same LM Guide model can achieve without flaking (scale-like pieces on the metal surface) after individually running under the same conditions.

## - Nominal Life Calculation Formula for Model HCR

$$L = \left( \frac{f_H \cdot f_T \cdot f_C}{f_W} \cdot \frac{C}{P_C} \right)^3 \times 50$$

- L : Nominal life (km)
- C : Basic dynamic load rating (N)
- P<sub>C</sub> : Calculated load (N)
- f<sub>H</sub> : Hardness factor
- f<sub>T</sub> : Temperature factor
- f<sub>C</sub> : Contact factor
- f<sub>W</sub> : Load factor

### [f<sub>H</sub>: Hardness Factor]

To ensure the achievement of the optimum load capacity of the LM Guide, the raceway hardness must be between 58 and 64 HRC.

If the hardness is lower than this range, the basic dynamic load rating and the basic static load rating decrease. Therefore, it is necessary to multiply each rating by the respective hardness factor (f<sub>H</sub>).

Since the LM Guide has sufficient hardness, the f<sub>H</sub> value for the LM Guide is normally 1.0 unless otherwise specified.

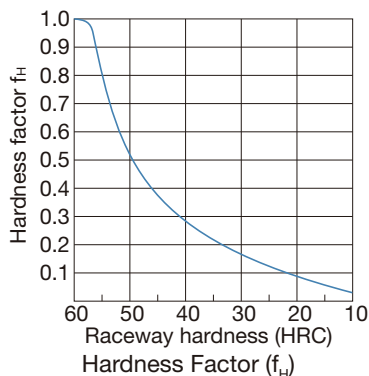

### [f<sub>T</sub>: Temperature Factor]

If the temperature of the environment surrounding the operating LM Guide exceeds 100°C, take into account the adverse effect of the high temperature and multiply the basic load ratings by the temperature factor.

In addition, the selected LM Guide must also be of a high temperature type.

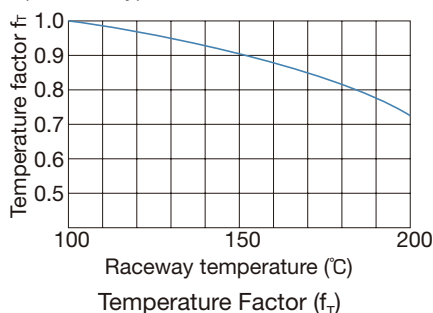

### [f<sub>C</sub>: Contact Factor]

When multiple LM blocks are used in close contact with each other, it is difficult to achieve uniform load distribution due to moment loads and mounting-surface accuracy. When using multiple blocks in close contact with each other, multiply the basic load rating (C or C<sub>0</sub>) by the corresponding contact factor indicated in. If uneven load distribution is expected in a large machine, take into account the respective contact factor.

Contact Factor (f<sub>C</sub>)

Number of blocks used in close contact	Contact factor f <sub>C</sub>
2	0.81
3	0.72
4	0.66
5	0.61
6 or larger	0.6
Normal use	1

### [f<sub>W</sub>: Load Factor]

In general, reciprocating machines tend to involve vibrations or impact during operation. It is difficult to accurately determine vibrations generated during high-speed operation and impact during frequent start and stop motion.

In the event of excessive speed vibration, divide the basic dynamic load rating by the corresponding load factor, using the empirically obtained figures.

Load Factor (f<sub>W</sub>)

Vibration/Impact	Velocity (V)	f <sub>W</sub>
Faint	Very low V ≤ 0.25m/s	1 to 1.2
Weak	Slow 0.25 < V ≤ 1m/s	1.2 to 1.5
Medium	Medium 1 < V ≤ 2m/s	1.5 to 2

## ●Calculating the Applied Load

The LM Guide is capable of receiving loads and moments in any directions that are generated due to the installation direction, alignment, gravity center position of a traveling object, thrust position and cutting resistance. Calculate the load and moment as "calculated load" and then calculated the nominal life.





## Equivalent Load

When the LM block of model HCR receives loads simultaneously in the radial and lateral directions, or the reverse radial and lateral directions, the equivalent factor is obtained from the equation below.

$$P_E = X \cdot P_{R(L)} + Y \cdot P_T$$

$P_E$  : Equivalent load (N)  
 -Radial direction  
 -Reverse radial direction  
 $P_L$  : Reverse radial load (N)  
 $P_T$  : Lateral load (N)  
 X, Y: Equivalent factor

Model HCR Equivalent factor in all directions



Classification	Model No.	If radial and lateral loads are applied simultaneously		If reverse radial and lateral loads are applied simultaneously	
					
		Equivalent in radial direction		Equivalent in reverse radial direction	
					
		X	Y	X	Y
4-way Equal Load	HCR	1.000	1.000	1.000	1.000

## Rated Loads in All Directions

Model HCR can bear loads and moments in any directions, including a radial load ( $P_R$ ), reverse radial load ( $P_L$ ) and lateral loads ( $P_T$ ), simultaneously.

The basic load rating is equal in four directions (radial, reverse radial and lateral directions), and their values are expressed in the corresponding specification tables of model HCR.

Model HCR Rated Loads in all directions

Classification	Model No.	Reverse radial direction		Lateral direction	
					
		Dynamic load rating $C_L$	Static load rating $C_{0L}$	Dynamic load rating $C_T$	Static load rating $C_{0T}$
4-way Equal Load	HCR	C	$C_0$	C	$C_0$

## ●Materials of Block and Rail

Model HCR uses carbon steel for both LM blocks and rails. If you want types strong against rust, use surface treatment.

## ●LM Rail Joint Type

If the LM Guide is used in whirling motion or rotational motion, the LM rail joint type is available.

To use the joint type, combine the joint marks displayed on the LM rails.



When two LM Guides with connected rails are to be arranged in parallel to each other, the two LM Guides will be manufactured so that the two LM Guides are axisymmetrically aligned.

If a large load is applied near the LM rail joint, the LM rail may deflect and cause misalignment.

Therefore, we recommend securely fastening the joint section by pressing the LM rail against the datum plane using a set screw or the like and keeping distance between mounting holes including butt joint portion. Contact THK for details.

## ● Surface Treatment of the LM Guide

For the LM Guide, three types of surface treatment, THK-AP treatment, are available for the purpose of corrosion resistance and appearance.

Surface Treatment	Features	Appearance
AP-HC	Equivalent to industrial-use hard chrome plating, AP-HC achieves almost the same level of corrosion resistance as martensite stainless steel. In addition, it is highly wear resistant since the film hardness is extremely high, 750 HV or higher.	
AP-C	A type of industrial-use black chrome coating designed to increase corrosion resistance. It achieves lower cost and higher corrosion resistance than martensite stainless steel.	
AP-CF	A compound treatment that combines black chrome coating and special fluorine resin coating and is suitable for applications requiring corrosion resistance.	

Note that the inside of the mounting hole of the LM blocks and LM rail is not provided with surface treatment.

In addition to the above treatments, other surface treatments are sometimes performed on areas other than the raceways, such as alkaline coloring treatment (black oxidizing) and color anodize treatment. However, some of them are not suitable for LM systems. For details, contact THK. If using an LM system whose raceways are surface treated, set a higher safety factor.

## ● Contamination Protection Accessories to Attach to LM Blocks

### End Seal

This is a general seal to attach to both ends of a LM block.

Attach this in normal environments (atmosphere and room temperature) and contaminated environments (dust and cutting chips).

One of its purposes is to remove dust from the upper face and side face of the LM rail. In addition to contamination protection, it is also a purpose to retain the lubricant in the LM block.

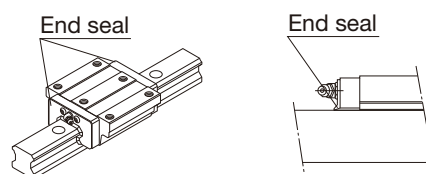

### Side Seal

This is a general seal to attach to the lower part of a LM block.

Attach this in normal environments (atmosphere and room temperature) and contaminated environments (dust and cutting chips).

Its purpose is to prevent entrance of dust from the bottom of the LM block. This contamination protection accessory is especially useful for environments where the mounting orientation is inverted mount or dust flutters.

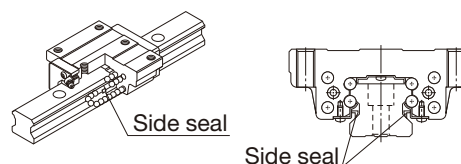

### Double Seals

These seals are double-end seals to attach to both ends of the LM block.

Its purpose is to remove dust and cutting chips from parts with much dust and cutting chips.

Note that it extends the overall length of the LM blocks.

For the overall length of the LM blocks, see the specification table of each LM Guide type.

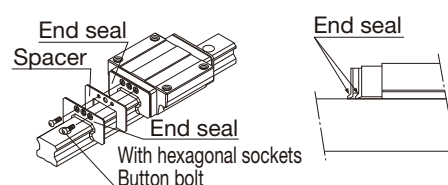

## Metal Scraper (Non-contact)

This is a metallic non-contact seal to attach to both ends of a LM block.  
 Be sure to attach this in environments where the sputter of welding, etc. adheres to the LM rail. If the normal end seal is used alone, it will be damaged soon.  
 Note that it extends the overall length of the LM blocks.  
 For the overall length of the LM blocks, see the specification table of each LM Guide type.

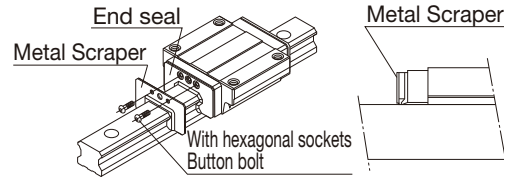

## Low-resistance Seal

This is a seal to attach to both ends of a LM block.  
 Use this if you want lower resistance than that of the end seal.  
 One of its purposes is to remove dust from the upper face and side face of the LM rail.

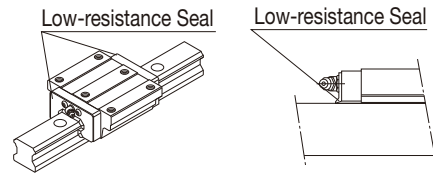

## Contamination Protection Accessories to Attach to LM Rail

### Dedicated Cap C (C Cap)

This is a special resin caps designed to cover the mounting holes in LM rails.  
 Preventing any influx of cutting chips or foreign material from the top face of the LM rail into the LM block, coupled with the use of seals, will improve the contamination protection performance for the LM guide.

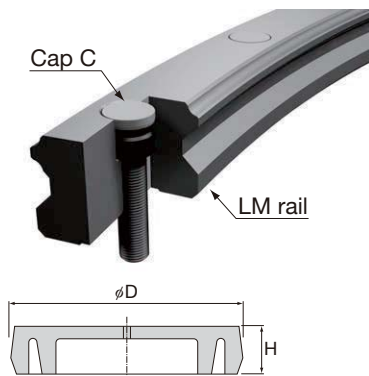

#### Model HCR C cap support list

Unit: mm

HCR		Size					
		12	15	25	35	45	65
C cap Model No.		C3	C4	C6	C8	C12	C16
Bolt used		M3	M4	M6	M8	M12	M16
Main dimensions	D	6.3	7.9	11.6	14.5	20.5	26.5
	H	1.2	1.0	2.7	3.7	4.7	5.7

### Dedicated Cap GC (GC Cap)

This is a metal cap designed to cover the mounting holes on LM rails (in compliance with RoHS directives).  
 Preventing any influx of coolant or minute foreign material from the top face of the LM rail into the LM block more by C cap, coupled with the use of seals, will dramatically improve the contamination protection performance for the LM guide.

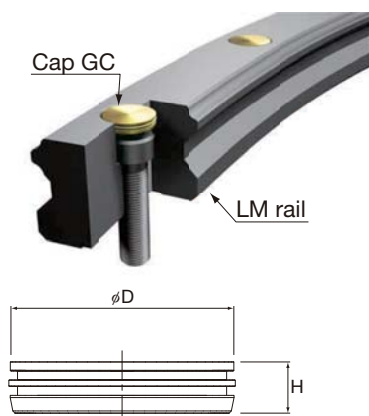

#### Model HCR GC cap support list

Unit: mm

HCR		Size					
		12	15	25	35	45	65
GC cap Model No.		—	—	GC6	GC8	GC12	GC16
Bolt used		—	—	M6	M8	M12	M16
Main dimensions	D	—	—	11.36	14.36	20.36	26.36
	H	—	—	2.5	3.5	4.6	5.0

- LM guides with GC caps are special rails.

## ●Shoulder Height of the Mounting Base and the Corner Radius

Normally, the mounting base for the LM rail and the LM block has a reference-surface on the sideface of the shoulder of the base in order to allow easy installation and highly accurate positioning.

The corner of the mounting shoulder must be machined to have a recess, or machined to be smaller than the corner radius "r," to prevent interference with the chamfer of the LM rail or the LM block.

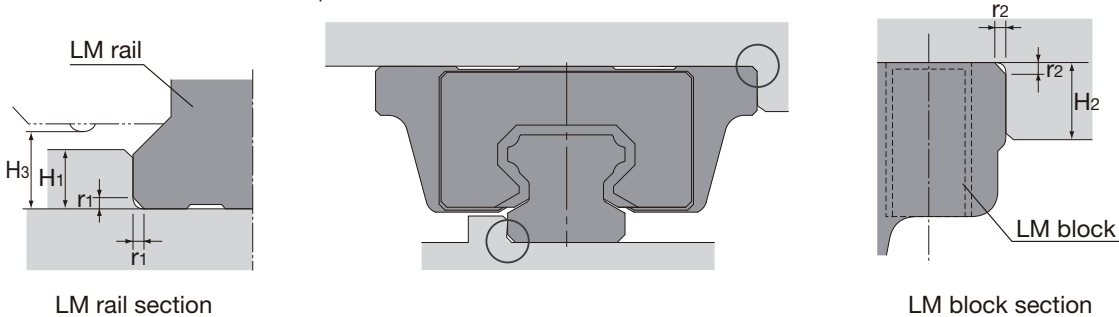

LM rail section

LM block section

Unit: mm

Model No.	LM rail Corner radius $r_1(\text{max})$	LM block Corner radius $r_2(\text{max})$	LM rail shoulder height $H_1$	LM block maximum shoulder height $H_2$	$H_3$
HCR	12	0.8	2.6	6	3.1
	15	0.5	3	4	4.8
	25	1	5	5	7
	35	1	6	6	8.5
	45	1	8	8	11.5
	65	1.5	1.5	10	10

## Recommended Tightening Torque for LM Rails

It is recommended to apply the screw tightening torque value when mounting the LM rails to the machine.

The tightening torque varies according to the material of the counterpart.

Tightening torque when  
Hexagonal-Socket-Head type bolts are used  
Unit: N-cm

Screw model	Tightening torque		
	Steel	Cast Iron	Aluminum
M3	196	127	98
M4	412	274	206
M6	1370	921	686
M8	3040	2010	1470
M12	11800	7840	5880
M16	19600	13100	9800

## ●Procedure to Mount the LM Guide

The LM Guide can be mounted easily with high accuracy by removing the burr, dent or dust on the mounting surface of the counterpart to which the LM Guide is to be mounted and mounting it as specified in the procedure.

To install the LM rails of R Guide model HCR, we recommend having any form of datum point (such as a pin) on the reference side (inside) of the LM rail, and pressing the LM rail to the datum point then stopping the LM rail with a presser plate from the counter-reference surface.

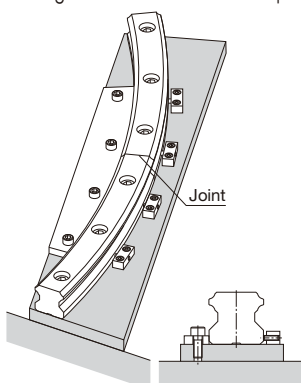

Method for Securing the LM Rails at the Joint

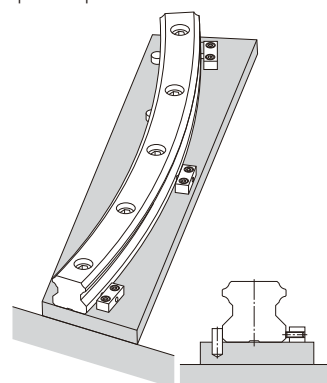

Method for Securing the LM Rail Using a Pin as a Datum Point



# HMG

## LM Guide Straight-Curved Guide Model HMG

LM Guide enabling both linear and curved motion at the same time.

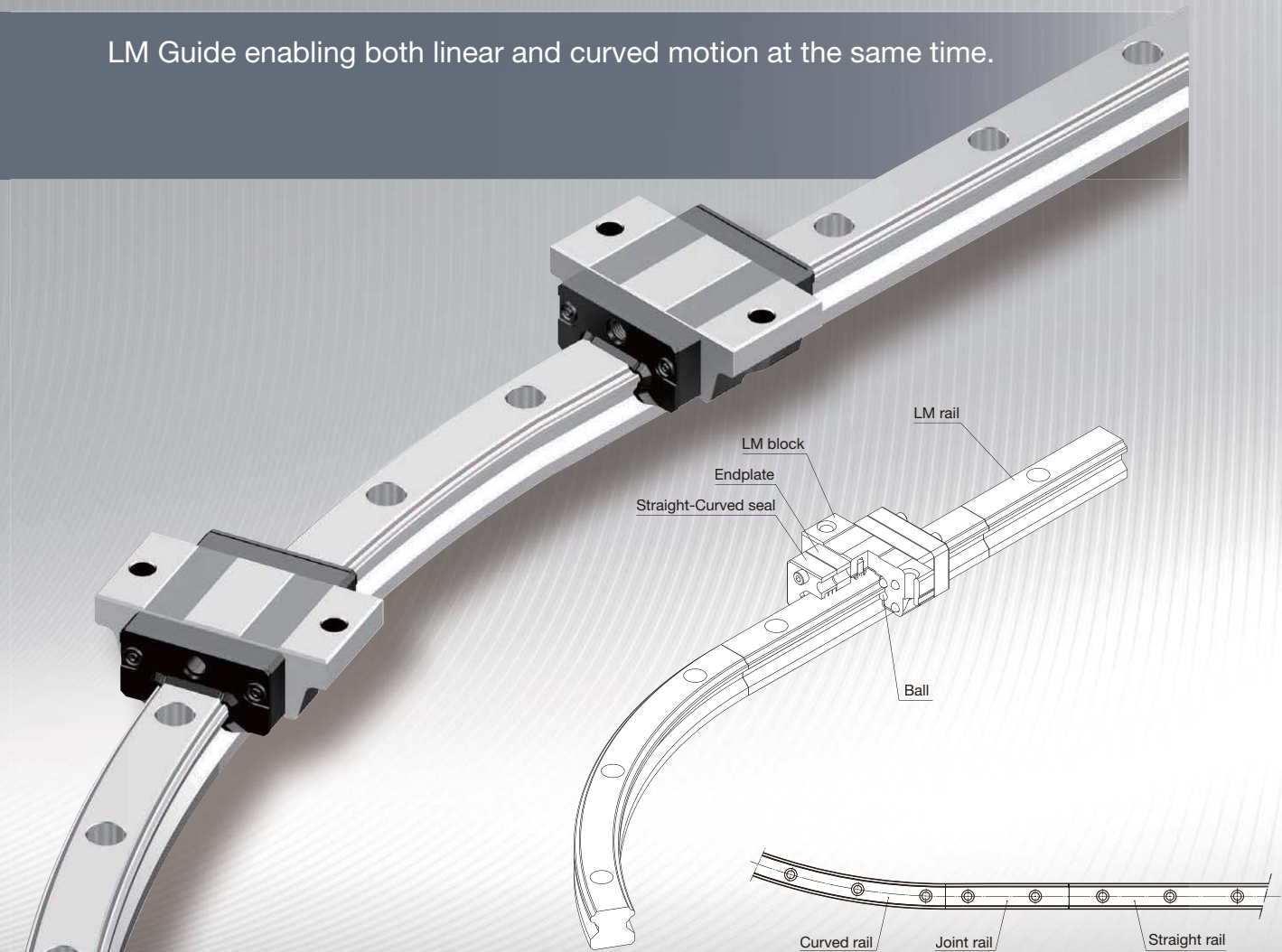

### Structure

Balls roll in four rows of raceways precision-ground on an LM rail and an LM block, and endplates incorporated in the LM block allow the balls to circulate to realize infinite motion.

Since retainer plates hold the balls, they do not fall off even if the LM block is pulled out from LM rail.

(Ball may fall depending on the handling. Use dummy rail when removing the LM block.)

When mounting the LM block on an LM rail, slide it onto a straight rail or a joint rail.)

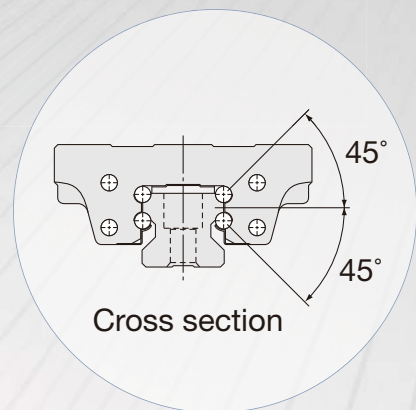

# Features

## 1 Freedom of Design

The Straight-Curved Guide HMG is a new straight-curved guide that allows the same type of LM blocks to continuously move on straight and curved rails by combining the technologies of the LM Guide HSR and the R Guide HCR. As the preload is available, high accurate circular motion and whirling motion without clearance can be realized easily.

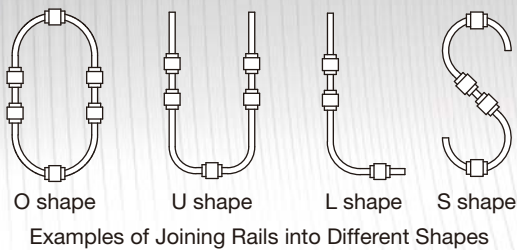

## 2 Cost Reduction through a Simplified Mechanism

Combination of straight and curved rails eliminates a lift and a turntable conventionally used for changing directions in the conveyance and production lines. Therefore, use of HMG simplifies the mechanism and eliminates a large number of parts, allowing the cost to be reduced. Additionally, man-hours in designing can also be reduced.

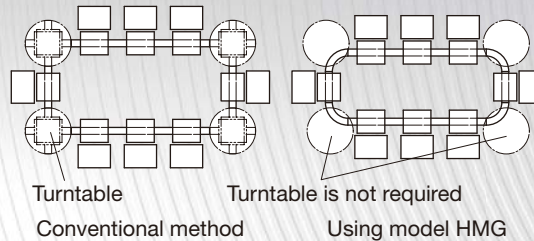

## 3 4-way Equal Load

Each row of balls is placed at a contact angle of 45° so that the rated loads applied to the LM block are uniform in the four directions (radial, reverse radial and lateral directions). Therefore, it can be used in any installation directions and used for a wide range of applications.

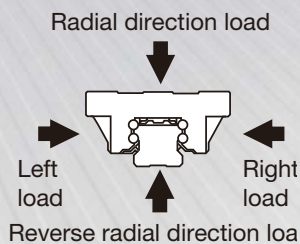

## 4 Self-aligning Capability

The self-aligning capability through face-to-face configuration of THK's unique circular-arc grooves (DF structure) enables a mounting error to be absorbed even under a preload, thus to achieve highly accurate, smooth circular motion and whirling motion.

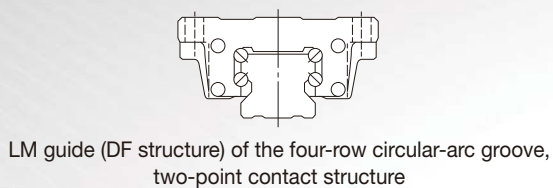

## ●Selecting a Preload

Model HMG includes two radial clearance (preload).

The radial clearance greatly affects the running accuracy, load carrying capacity and rigidity of the LM Guide, it is important to select an appropriate radial clearance according to the application.

An appropriate radial clearance reduces vibrations and impact generated during the operation of the device and favorably affects the service life and the accuracy.

### Types of Radial Clearance

Radial Clearance (Preload)	Radial clearance symbol	Usage conditions
Normal clearance	No symbol	- Parts which you want to move lightly
Clearance C1 (Light preload)	C1	- Parts where there are few vibration or impact - Parts used in a single-rail configuration - Parts which require light load and high accuracy

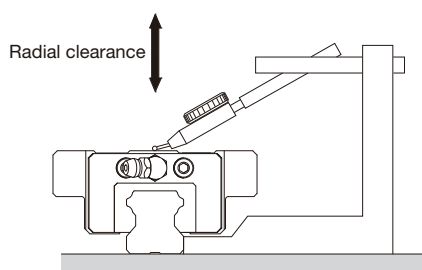

Radial clearance standard Unit:  $\mu\text{m}$

Model No.	Normal clearance	Clearance C1
HMG	15	-4 to +2
	25	-6 to +3
	35	-8 to +4
	45	-10 to +5
	65	-14 to +7

## ●Selecting the Accuracy Grade

Model HMG is available in normal grade only.

The accuracy standard is specified in terms of running parallelism, dimensional tolerance for height/width, and height/width difference between a pair when 2 or more LM blocks are used on one rail or when 2 or more rails are mounted on the same plane. (A gap is created at curved sections)

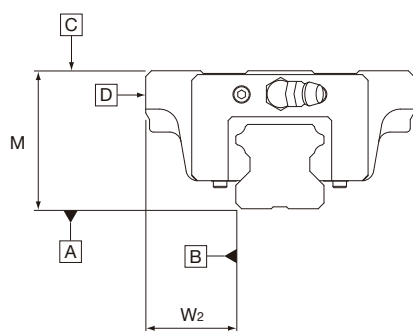

Running Parallelism Unit:  $\mu\text{m}$

LM rail length (mm)		Running Parallelism Values
Above	Or Less	Normal grade
—	125	30
125	200	37
200	250	40
250	315	44
315	400	49
400	500	53
500	630	58
630	800	64
800	1000	70
1000	1250	77
1250	1600	84
1600	2000	92

Accuracy Standards Unit: mm

Model No.	Accuracy Grade	Normal grade
	Item	No symbol
15	Dimensional tolerance in height M	$\pm 0.1$
	Difference in height M	0.02
	Dimensional tolerance in width $W_2$	$\pm 0.1$
	Dimensional in width $W_2$	0.02
	Running parallelism of surface C against surface A	$\Delta C$ (according to the running parallelism table above)
	Running parallelism of surface D against surface B	$\Delta D$ (according to the running parallelism table above)
25	Dimensional tolerance in height M	$\pm 0.1$
	Difference in height M	0.02
	Dimensional tolerance in width $W_2$	$\pm 0.1$
	Dimensional in width $W_2$	0.03
	Running parallelism of surface C against surface A	$\Delta C$ (according to the running parallelism table above)
	Running parallelism of surface D against surface B	$\Delta D$ (according to the running parallelism table above)
35	Dimensional tolerance in height M	$\pm 0.1$
	Difference in height M	0.03
	Dimensional tolerance in width $W_2$	$\pm 0.1$
	Dimensional in width $W_2$	0.03
	Running parallelism of surface C against surface A	$\Delta C$ (according to the running parallelism table above)
	Running parallelism of surface D against surface B	$\Delta D$ (according to the running parallelism table above)
45	Dimensional tolerance in height M	$\pm 0.1$
	Difference in height M	0.03
	Dimensional tolerance in width $W_2$	$\pm 0.1$
	Dimensional in width $W_2$	0.03
	Running parallelism of surface C against surface A	$\Delta C$ (according to the running parallelism table above)
	Running parallelism of surface D against surface B	$\Delta D$ (according to the running parallelism table above)
65	Dimensional tolerance in height M	$\pm 0.1$
	Difference in height M	0.03
	Dimensional tolerance in width $W_2$	$\pm 0.1$
	Dimensional in width $W_2$	0.03
	Running parallelism of surface C against surface A	$\Delta C$ (according to the running parallelism table above)
	Running parallelism of surface D against surface B	$\Delta D$ (according to the running parallelism table above)

## ● Optional Part

The following parts are available as optional parts of model HMG.

Select from them according to the conditions and environment.

For details of each optional product, see P.23.

### Model HMG Optional Parts Correspondence List

● : Compatible

HMG		Options Symbol	Size				
			15	25	35	45	65
Contamination protection accessories	End seal	UU	●	●	●	●	●
	Dedicated cap C	—	●	●	●	●	●
	Dedicated cap GC	—	—	●	—	—	—

## Maximum Resistance Value of Seal

This shows the maximum resistance value of seals per LM block with a lubricant applied.

Maximum resistance value of UU seal

Unit: N

Model No.		Seal symbol	Seal Maximum Resistance Value
HMG	15	UU	3
	25		6
	35		8
	45		12
	65		40

# HMG-A(15-65)

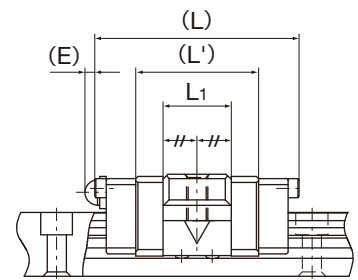
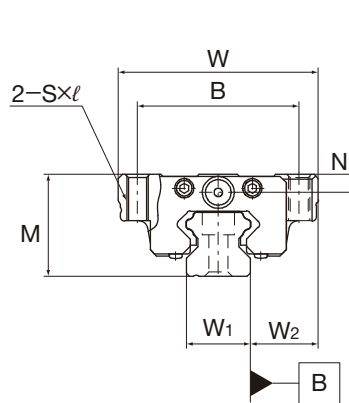

Model No.	Outer dimensions				LM block dimensions					LM rail dimensions			
	M	W	L	L'	B	S×ℓ	L <sub>1</sub>	N	E	LM rail			Height
										W <sub>1</sub>	W <sub>2</sub>	F	
<b>HMG 15A</b>	24	47	48	28.8	38	M5×11	16	4.3	5.5	15	16	60	15
<b>HMG 25A</b>	36	70	62.2	42.2	57	M8×16	25.6	6	12	23	23.5	60	22
<b>HMG 35A</b>	48	100	80.6	54.6	82	M10×21	32.6	8	12	34	33	80	29
<b>HMG 45A</b>	60	120	107.6	76.6	100	M12×25	42.6	10	16	45	37.5	105	38
<b>HMG 65A</b>	90	170	144.4	107.4	142	M16×37	63.4	19	16	63	53.5	150	53

## Model number coding

**HMG15A 2 UU C1 +1000L T + 60/150R 6T + 60/300R 6T -II**

- HMG15A**: Model number
- 2**: No. of LM blocks used on the same rail
- UU**: Contamination protection accessory symbol
- C1**: Radial clearance symbol (Normal (No symbol), Light preload (C1))
- +1000L**: Overall linear LM rail length per rail
- T**: Symbol for linear LM rail joint
- + 60/150R**: Center angle of one inner curved rail (60°) and Radius of inner curved rail (R 150)
- 6T**: No. of inner curved LM rails jointed
- + 60/300R**: Center angle of one outer curved rail (60°) and Radius of outer curved rail (R 300)
- 6T**: No. of outer curved LM rails jointed
- II**: Symbol for No. of rails used on the same plane

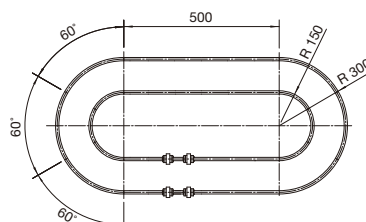

Example of model No.



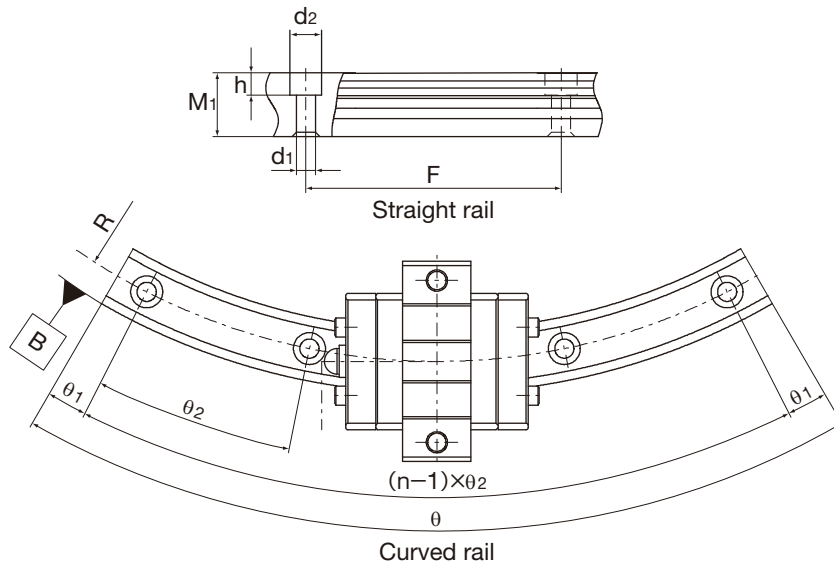

Unit: mm

Mounting hole	Curved rail						Basic dynamic load rating (C)	Basic static load rating (C <sub>0</sub> )	
	d <sub>1</sub> × d <sub>2</sub> × h	R	n	θ°	θ <sub>1</sub> °	θ <sub>2</sub> °		Resultant load (C) kN	Straight section (C <sub>0st</sub> ) kN
4.5 × 7.5 × 5.3	150	3	60	7	23	2.56	4.23	0.44	
	300	5	60	6	12				
	400	7	60	3	9				
7 × 11 × 9	500	9	60	2	7	9.41	10.8	6.7	
	750	12	60	2.5	5				
	1000	15	60	2	4				
9 × 14 × 12	600	7	60	3	9	17.7	19	11.5	
	800	11	60	2.5	5.5				
	1000	12	60	2.5	5				
	1300	17	60	2	3.5				
14 × 20 × 17	800	8	60	2	8	28.1	29.7	18.2	
	1000	10	60	3	6				
	1200	12	60	2.5	5				
	1600	15	60	2	4				
18 × 26 × 22	1000	8	60	2	8	66.2	66.7	36.2	
	1500	10	60	3	6				
	2000	12	45	0.5	4				
	2500	13	45	1.5	3.5				
	3000	10	30	1.5	3				

When a moment is applied where one LM block is specified per axis, the LM block may experience non-smooth motion. We recommend that multiple LM blocks be used per axis when a moment is applied.

Table shows the static permissible moment of an LM block in the M<sub>A</sub>, M<sub>B</sub> and M<sub>C</sub> directions.

Static Permissible Moments of Model HMG

Unit: kN-m

Model No.	M <sub>A</sub>		M <sub>B</sub>		M <sub>C</sub>	
	Straight section	Curved section	Straight section	Curved section	Straight section	Curved section
HMG 15A	0.008	0.007	0.008	0.01	0.027	0.003
HMG 25A	0.1	0.04	0.1	0.05	0.11	0.07
HMG 35A	0.22	0.11	0.22	0.12	0.29	0.17
HMG 45A	0.48	0.2	0.48	0.22	0.58	0.34
HMG 65A	1.47	0.66	1.47	0.73	1.83	0.94

\*Lubrication

Lithium soap base grease No. 2 (AFB-LF grease) is contained in model HMG as standard.

If you want any other grease or any types without grease, contact THK.

# LM Block Dimensions with Optional Parts

## ●Dimensions with Contamination Protection Accessories

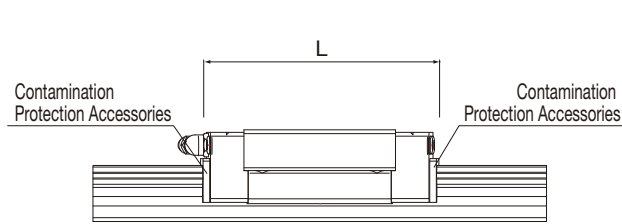

Unit:mm

Model No.		L
		UU
HMG	15A	48
	25A	62.2
	35A	80.6
	45A	107.6
	65A	144.4

## ●Calculating the Static Safety Factor

In a system subject to frequent starts and stops, placed under cutting forces or under a large moment caused by an overhang load, an excessively large load may apply to the LM Guide. When selecting a model number, make sure that the desired model is capable of receiving the required maximum load (whether stationary or in motion) and calculate the static safety factor.

When the radial load is large	$\frac{f_H \cdot f_T \cdot f_C \cdot C_0}{P_R} \geq f_s$
When the reverse radial load is large	$\frac{f_H \cdot f_T \cdot f_C \cdot C_{0L}}{P_L} \geq f_s$
When the lateral loads are large	$\frac{f_H \cdot f_T \cdot f_C \cdot C_{0T}}{P_T} \geq f_s$

$f_s$  : Static safety factor

$C_0$  : Basic static load rating (radial direction) (N)

$C_{0L}$  : Basic static load rating (reverse radial direction) (N)

$C_{0T}$  : Basic static load rating (lateral direction) (N)

$P_R$  : Calculated load (radial direction) (N)

$P_L$  : Calculated load (reverse radial direction) (N)

$P_T$  : Calculated load (lateral direction) (N)

$f_H$  : Hardness factor

$f_T$  : Temperature factor

$f_C$  : Contact factor

### Reference Values of Static Safety Factor ( $f_s$ )

Machine using the LM system	Load conditions	Lower limit of $f_s$
General industrial machinery	Without vibration or impact	1.0 to 3.5
	With vibration or impact	2.0 to 5.0
Machine tool	Without vibration or impact	1.0 to 4.0
	With vibration or impact	2.5 to 7.0

## ●Calculating the Nominal Life

The service life of an LM Guide is subject to variations even under the same operational conditions.

Therefore, it is necessary to use the nominal life defined below as a reference value for obtaining the service life of the LM Guide.

The nominal life (L) means the total travel distance that 90% of a group of units of the same LM Guide model can achieve without flaking (scale-like pieces on the metal surface) after individually running under the same conditions.

### - Nominal Life Calculation Formula for Model HMG

$$L = \left( \frac{f_H \cdot f_T \cdot f_C \cdot C}{P_C} \right)^3 \times 50$$

L : Nominal life (km)

C : Basic dynamic load rating (N)

$P_C$  : Calculated load (N)

$f_H$  : Hardness factor

$f_C$  : Contact factor

$f_T$  : Temperature factor

$f_W$  : Load factor

### [f<sub>H</sub>: Hardness Factor]

To ensure the achievement of the optimum load capacity of the LM Guide, the raceway hardness must be between 58 and 64 HRC.

If the hardness is lower than this range, the basic dynamic load rating and the basic static load rating decrease. Therefore, it is necessary to multiply each rating by the respective hardness factor (f<sub>H</sub>).

Since the LM Guide has sufficient hardness, the f<sub>H</sub> value for the LM Guide is normally 1.0 unless otherwise specified.

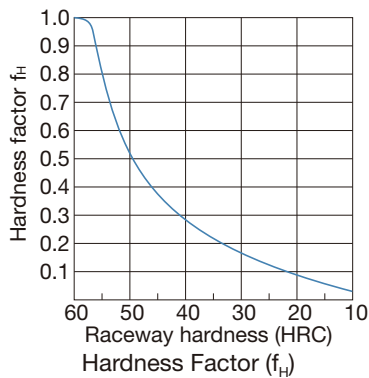

### [f<sub>T</sub>: Temperature Factor]

If the temperature of the environment surrounding the operating LM Guide exceeds 100°C, take into account the adverse effect of the high temperature and multiply the basic load ratings by the temperature factor.

In addition, the selected LM Guide must also be of a high temperature type.

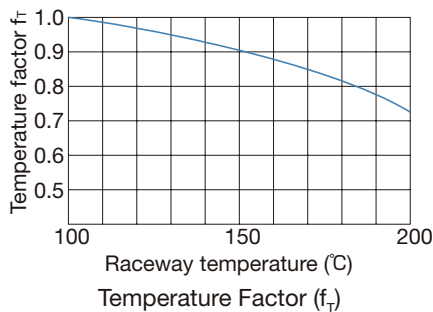

### [f<sub>C</sub>: Contact Factor]

When multiple LM blocks are used in close contact with each other, it is difficult to achieve uniform load distribution due to moment loads and mounting-surface accuracy. When using multiple blocks in close contact with each other, multiply the basic load rating (C or C<sub>0</sub>) by the corresponding contact factor indicated in. If uneven load distribution is expected in a large machine, take into account the respective contact factor.

Contact Factor (f<sub>C</sub>)

Number of blocks used in close contact	Contact factor f <sub>C</sub>
2	0.81
3	0.72
4	0.66
5	0.61
6 or larger	0.6
Normal use	1

### [f<sub>w</sub>: Load Factor]

In general, reciprocating machines tend to involve vibrations or impact during operation. It is difficult to accurately determine vibrations generated during high-speed operation and impact during frequent start and stop motion.

In the event of excessive speed vibration, divide the basic dynamic load rating by the corresponding load factor, using the empirically obtained figures.

Load Factor (f<sub>w</sub>)

Vibration/Impact	Velocity (V)	f <sub>w</sub>
Faint	Very low V ≤ 0.25m/s	1 to 1.2
Weak	Slow 0.25 < V ≤ 1m/s	1.2 to 1.5
Medium	Medium 1 < V ≤ 2m/s	1.5 to 2

## ● Calculating the Applied Load

The LM Guide is capable of receiving loads and moments in any directions that are generated due to the installation direction, alignment, gravity center position of a traveling object, thrust position and cutting resistance. Calculate the load and moment as "calculated load" and then calculated the nominal life.

### Equivalent Load

When the LM block of model HMG receives loads simultaneously in the radial and lateral directions, or the reverse radial and lateral directions, the equivalent factor is obtained from the equation below.

$$P_E = X \cdot P_{R(L)} + Y \cdot P_T$$

- P<sub>E</sub> : Equivalent load (N)
- Radial direction
- Reverse radial direction
- P<sub>L</sub> : Reverse radial load (N)
- P<sub>T</sub> : Lateral load (N)
- X, Y : Equivalent factor

Model HMG Equivalent factor in all directions



Classification	Model No.	If radial and lateral loads are applied simultaneously		If reverse radial and lateral loads are applied simultaneously	
		Equivalent in radial direction		Equivalent in reverse radial direction	
		X	Y	X	Y
4-way Equal Load	HMG	1.000	1.000	1.000	1.000

## Rated Loads in All Directions

Model HMG can bear loads and moments in any directions, including a radial load ( $P_R$ ), reverse radial load ( $P_L$ ) and lateral loads ( $P_T$ ), simultaneously.

The basic load rating is equal in four directions (radial, reverse radial and lateral directions), and their values are expressed in the corresponding specification tables of model HMG.

### Model HMG Rated Loads in all directions

Classification	Model No.	Reverse radial direction 		Lateral direction 	
		Dynamic load rating $C_L$	Static load rating $C_{0L}$	Dynamic load rating $C_T$	Static load rating $C_{0T}$
4-way Equal Load	HMG	C	$C_0$	C	$C_0$



## Materials of Block and Rail

Model HMG uses carbon steel for both LM blocks and rails.

If you want types strong against rust, use surface treatment.

## Surface Treatment of the LM Guide

For the LM Guide, three types of surface treatment, THK-AP treatment, are available for the purpose of corrosion resistance and appearance.

Surface Treatment	Features	Appearance
AP-HC	Equivalent to industrial-use hard chrome plating, AP-HC achieves almost the same level of corrosion resistance as martensite stainless steel. In addition, it is highly wear resistant since the film hardness is extremely high, 750 HV or higher.	
AP-C	A type of industrial-use black chrome coating designed to increase corrosion resistance. It achieves lower cost and higher corrosion resistance than martensite stainless steel.	
AP-CF	A compound treatment that combines black chrome coating and special fluorine resin coating and is suitable for applications requiring corrosion resistance.	

Note that the inside of the mounting hole of the LM blocks and LM rail is not provided with surface treatment.

In addition to the above treatments, other surface treatments are sometimes performed on areas other than the raceways, such as alkaline coloring treatment (black oxidizing) and color anodize treatment. However, some of them are not suitable for LM systems. For details, contact THK.

If using an LM system whose raceways are surface treated, set a higher safety factor.

## Jointed LM rail

### [Level Difference Specification for the Joint]

An accuracy error in LM rail installation has influence on the service life of the product.

When installing the LM rail, take care to minimize the level difference in the joint within the specification indicated in Table. For the joint between curved rails and another between the curved section and the joint rail, we recommend using a flushing piece like the one shown in Figure. When using the flushing piece, place the fixed butt piece on the outer side, push the rail against the butt piece, and then adjust the level difference in the joint section by turning the adjustment screw from the inner side.

### Level Difference Specification for the Joint

Unit: mm

Model No.	Ball raceway, side face	Upper face	Maximum clearance of the joint section
	a	b	c
15	0.01	0.02	0.6
25	0.01	0.02	0.7
35	0.01	0.02	1.0
45	0.01	0.02	1.3
65	0.01	0.02	1.3

Note) Place the pin on the outer circumference and the bolt on the inner circumference.

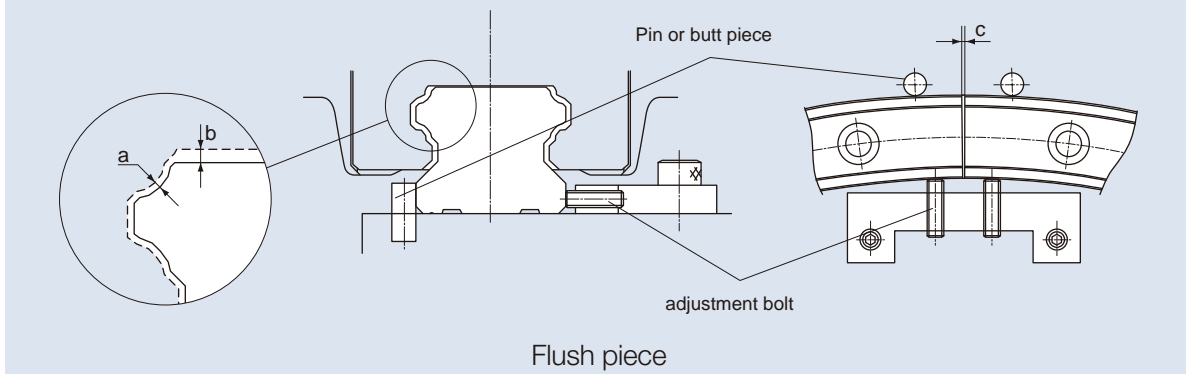

### [About the Curved Section]

The curved section of model HMG has a clearance for a structural reason. Therefore, this model may not be used in applications where highly accurate feed is required. In addition, the curved section cannot withstand a large moment. When a large moment is applied, it is necessary to increase the number of LM blocks or LM rails. For permissible moment values, see P18.

### [Jointed LM Rail]

Model HMG always requires a jointed rail where an LM block travels from the straight section to the curved section and where the curve is inverted such as an S curve. Take this into account when design the system.

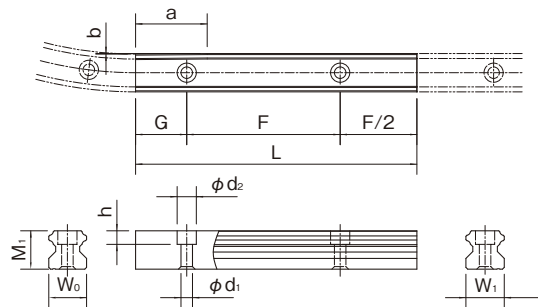

Dimension of the Jointed Rail

Unit : mm

Model No.	Dimension of the jointed rail							
	Height	Pitch	Mounting hole	Width		Taper length	Taper depth	Radius
	$M_1$	F	$d_1 \times d_2 \times h$	$W_1$	$W_0$	a	b	R
15	15	60	4.5×7.5×5.3	15	14.78	28	0.22	150
					14.89		0.11	300
					14.92		0.08	400
25	22	60	7×11×9	23	22.83	42	0.17	500
					22.89		0.11	750
					22.92		0.08	1000
35	29	80	9×14×12	34	33.77	54	0.23	600
					33.83		0.17	800
					33.86		0.14	1000
					33.9		0.1	1300
45	38	105	14×20×17	45	44.71	76	0.29	800
					44.77		0.23	1000
					44.81		0.19	1200
					44.86		0.14	1600
65	53	150	18×26×22	63	62.48	107	0.52	1000
					62.66		0.34	1500
					62.74		0.26	2000
					62.8		0.2	2500
					62.83		0.17	3000



## ● Contamination Protection Accessories to Attach to LM Blocks

### End Seal

This is a general seal to attach to both ends of a LM block.

Attach this in normal environments (atmosphere and room temperature) and contaminated environments (dust and cutting chips).

One of its purposes is to remove dust from the upper face and side face of the LM rail.

In addition to contamination protection, it is also a purpose to retain the lubricant in the LM block.

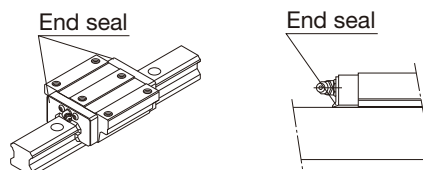

## ● Contamination Protection Accessories to Attach to LM Rail

### Dedicated Cap C (C Cap)

This is a special resin caps designed to cover the mounting holes in LM rails.

Preventing any influx of cutting chips or foreign material from the top face of the LM rail into the LM block, coupled with the use of seals, will improve the contamination protection performance for the LM guide.

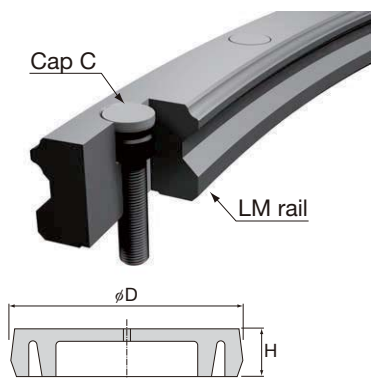

#### ● Model HMG C cap support list

Unit: mm

HMG		Size				
		15	25	35	45	65
C cap Model No.		C4	C6	C8	C12	C16
Bolt used		M4	M6	M8	M12	M16
Main dimensions	D	7.8	11.4	14.4	20.5	26.5
	H	1.0	2.7	3.7	4.7	5.7

### Dedicated Cap GC (GC Cap)

This is a metal cap designed to cover the mounting holes on LM rails (in compliance with RoHS directives).

Preventing any influx of coolant or minute foreign material from the top face of the LM rail into the LM block more by C cap, coupled with the use of seals, will dramatically improve the contamination protection performance for the LM guide.

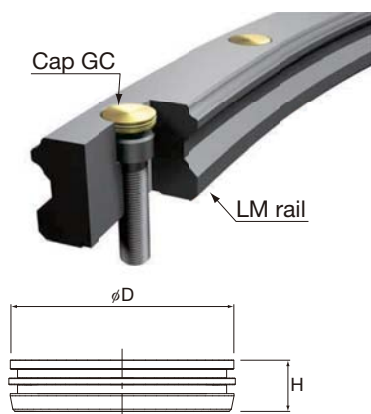

#### ● Model HMG GC cap support list

Unit: mm

HMG		Size				
		15	25	35	45	65
GC cap Model No.		—	GC6	—	—	—
Bolt used		—	M6	—	—	—
Main dimensions	D	—	11.36	—	—	—
	H	—	2.5	—	—	—

- LM guides with GC caps are special rails.

## ● Shoulder Height of the Mounting Base and the Corner Radius

Normally, the mounting base for the LM rail and the LM block has a reference-surface on the sideface of the shoulder of the base in order to allow easy installation and highly accurate positioning.

The corner of the mounting shoulder must be machined to have a recess, or machined to be smaller than the corner radius "r," to prevent interference with the chamfer of the LM rail or the LM block.

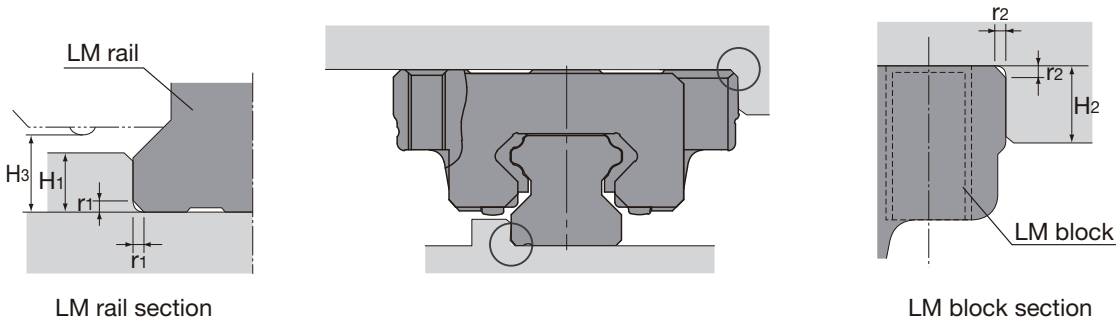

Unit:mm

Model No.	LM rail Corner radius $r_1(\text{max})$	LM block Corner radius $r_2(\text{max})$	LM rail shoulder height $H_1$	LM block maximum shoulder height $H_2$	$H_3$	
HMG	15	0.5	0.5	3	4	3.5
	25	1	1	5	5	5.5
	35	1	1	6	6	7.5
	45	1	1	8	8	11
	65	1.5	1.5	10	10	16

## Recommended Tightening Torque for LM Rails

It is recommended to apply the screw tightening torque value when mounting the LM rails to the machine. The tightening torque varies according to the material of the counterpart.

Tightening torque when  
Hexagonal-Socket-Head type bolts are used  
Unit: N-cm

Screw model	Tightening torque		
	Steel	Cast Iron	Aluminum
M4	412	274	206
M6	1370	921	686
M8	3040	2010	1470
M12	11800	7840	5880
M16	19600	13100	9800

## ● Examples of Table Mechanisms

The Straight-Curved Guide HMG requires a rotating mechanism or a slide mechanism for the table to rotate the curved sections when 2 or more rails are used or when 2 or more LM blocks are connected on a single rail. Refer to Fig.1 for examples of such mechanisms.

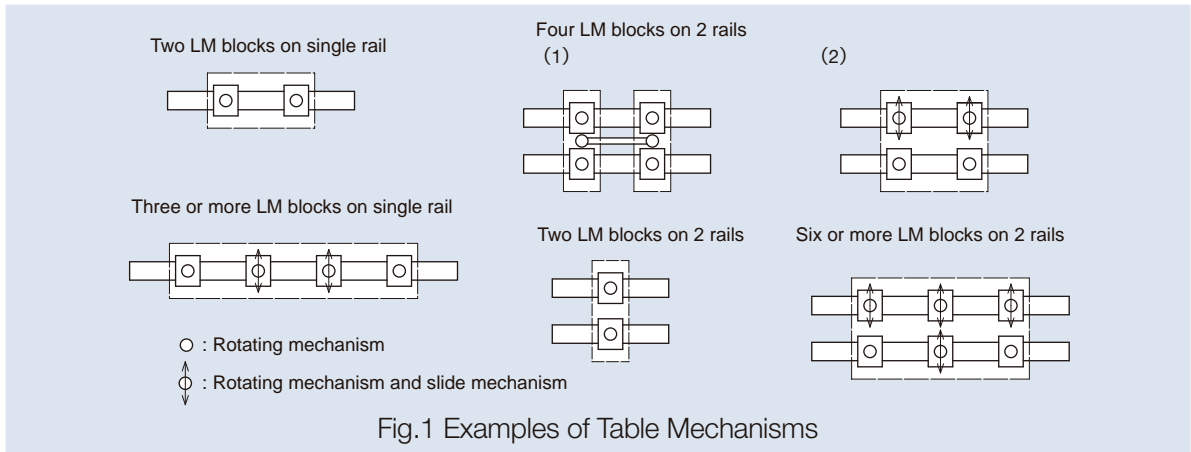

Fig.2 shows examples of designing a table when units are used on multiple axes. HMG requires a rotating mechanism and a slide mechanism since the table is decentered when an LM block transits from a straight section to a curved section. The amount of decentering differs according to the radius of the curved section and the LM block span. Therefore, it is necessary to design the system in accordance with the corresponding specifications.

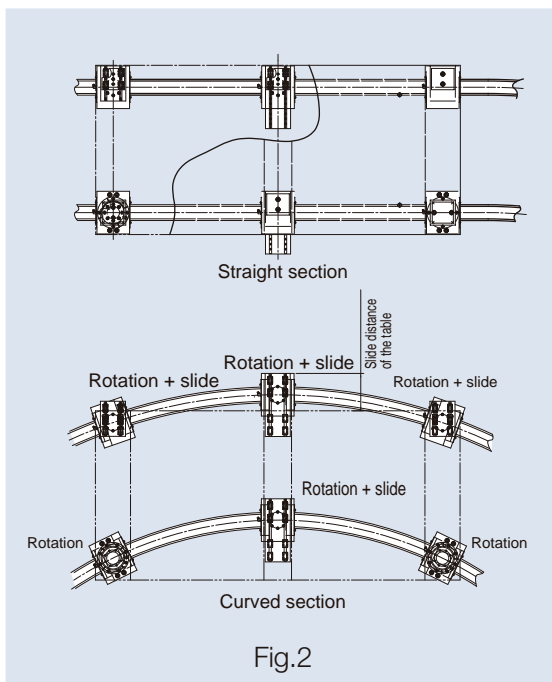
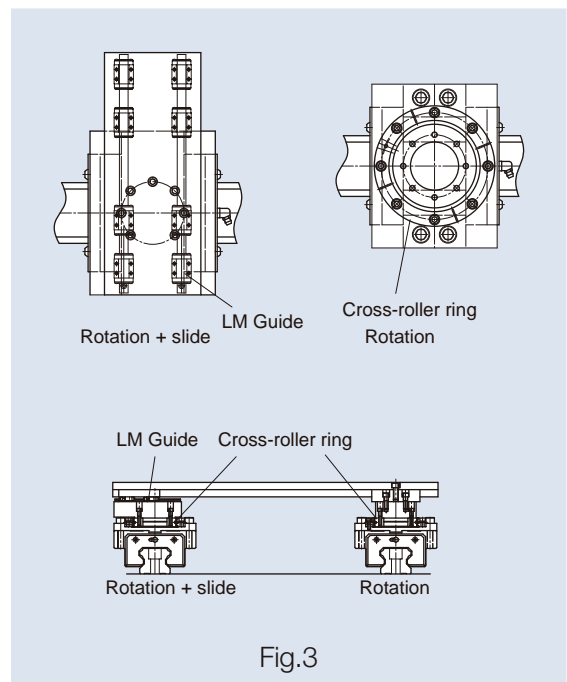

Fig.3 shows detail drawings of the slide and rotating mechanisms. In the figure, LM Guides are used in the slide mechanism and Cross-Roller Rings in the rotating mechanism to achieve smooth sliding and rotating motions. For driving the Straight-Curved Guide, belt drives and chain drives are available.



## ● Precautions on Using the LM Guide

### [Handling]

- (1) Please use at least two people to move any product weighing 20 kg or more, or use a dolly or another conveyance. Doing so may cause injury or damage.
- (2) Do not disassemble the parts. This will result in loss of functionality.
- (3) Tilting an LM block or LM rail may cause them to fall by their own weight.
- (4) Take care not to drop or strike the LM Guide. Doing so may cause injury or damage. Giving an impact to it could also cause damage to its function even if the product looks intact.
- (5) Do not remove the LM block from the LM rail during setup.
- (6) Do not insert hands or fingers into the mounting holes on the LM rail, as they could get caught between the rail and the LM block, resulting in injury.
- (7) To ensure personal safety, wear gloves and protective footwear when handling this product.

### [Precautions on Use]

- (1) Prevent foreign material, such as cutting chips or coolant, from entering the product. Failure to do so may cause damage.
- (2) If the product is used in an environment where cutting chips, coolant, corrosive solvents, water, etc., may enter the product, use bellows, covers, etc., to prevent them from entering the product.
- (3) Do not use this product if the external temperature exceeds 80°C. Unless the unit is specially designed to be heat-resistant, exposure to such temperatures may deform or damage plastic and rubber parts.
- (4) If foreign material such as cutting chips adheres to the product, replenish the lubricant after cleaning the product.
- (5) Micro-strokes tend to obstruct oil film to form on the raceway in contact with the rolling element, and may lead to fretting corrosion. Take consideration using grease offering excellent fretting prevention. It is also recommended that a stroke movement corresponding to the length of the LM block be made on a regular basis to make sure oil film is formed between the raceway and rolling element.
- (6) Do not use undue force when fitting parts (pin, key, etc.) to the product. This may generate permanent deformation on the raceway, leading to loss of functionality.
- (7) If, for operational reasons, it becomes absolutely necessary to remove the LM block from the LM rail and reattach it, a special mounting jig must be used for this purpose. (The mounting jig is not included with standard versions of the product. To obtain one, please contact THK.)
- (8) Position the mounting jig so that one end abuts the end of the LM rail. When the rail and the jig are exactly aligned, the LM block can be loaded onto the rail.
- (9) Take care to keep the LM block straight. Loading the block at an angle can introduce foreign matter, damage internal components, or cause balls to fall out.
- (10) The LM block must contain all its internal rolling elements (balls) when mounted on the LM rail. Using a block with any balls removed may result in premature damage.
- (11) Please contact THK if any balls fall out of the LM block; do not use the block if any balls are missing.
- (12) If the end plate is damaged due to an accident, etc., balls may fall out or the LM block may become detached from the LM rail and drop. If the LM Guide will be used hanging upside down, take preventive measures such as adding a safety mechanism to prevent falls.
- (13) Insufficient rigidity or accuracy of mounting members causes the bearing load to concentrate on one point and the bearing performance will drop significantly. Accordingly, give sufficient consideration to the rigidity/accuracy of the housing and base and strength of the fixing bolts.

- (14) When removing the LM block from the LM rail and then replacing the block, an LM block mounting/removing jig that facilitates such installation is available. Contact THK for details.

## [Lubrication]

- (1) Thoroughly remove anti-rust oil and feed lubricant before using the product.
- (2) Do not mix different lubricants. Mixing greases using the same type of thickening agent may still cause adverse interaction between the two greases if they use different additives, etc.
- (3) When using the product in locations exposed to constant vibrations or in special environments such as clean rooms, vacuum and low/high temperature, use the grease appropriate for the specification/environment.
- (4) When lubricating the product having no grease nipple or oil hole, apply grease directly on the raceway and stroke the product several times to let the grease spread inside.
- (5) The consistency of grease changes according to the temperature. Take note that the slide resistance of the LM Guide also changes as the consistency of grease changes.
- (6) After lubrication, the slide resistance of the LM Guide may increase due to the agitation resistance of grease. Be sure to perform a break-in to let the grease spread fully, before operating the machine.
- (7) Excess grease may scatter immediately after lubrication, so wipe off scattered grease as necessary.
- (8) The properties of grease deteriorate and its lubrication performance drops over time, so grease must be checked and added properly according to the use frequency of the machine.
- (9) Although the lubrication interval may vary according to use conditions and the service environment, lubrication should be performed approximately every 100 km in travel distance (three to six months). Set the final lubrication interval/amount based on the actual machine.
- (10) If the mounting orientation is other than horizontal use, the lubricant may not reach the raceway completely. For the mounting orientation and the lubrication.
- (11) When adopting oil lubrication, the lubricant may not be distributed throughout the LM block depending on the mounting orientation of the block. Contact THK in advance for details.

## [Storage]

When storing the LM Guide, enclose it in a package designated by THK and store it in a room in a horizontal orientation while avoiding high temperature, low temperature and high humidity.

After the product has been in storage for an extended period of time, lubricant inside may have deteriorated, so add new lubricant before use.

## [Disposal]

Dispose of the product properly as industrial waste.

---

## Cap GC

---

### [Handling]

If GC caps are specified for the product, the edges of the LM rail mounting hole openings will be sharp. Take great care not to injure your fingers or hands while working.

When fitting GC caps, use a flat aligning tool to gradually punch the cap into the hole until it is level with the upper surface of the LM rail. Then run an oil stone over the rail until the upper surface of the rail and the GC caps are completely flat.

---

## LIMITED WARRANTY

**LIMITED WARRANTY AND LIMITATION OF LIABILITY:** THK CO. LTD., FOR ITSELF AND ITS RELATED COMPANIES AND SUBSIDIARIES (HEREINAFTER DESCRIBED COLLECTIVELY AS "THK" ) WARRANTS THAT ALL THK PRODUCTS SOLD WILL BE FREE OF DEFECTS IN MATERIALS AND WORKMANSHIP FOR A PERIOD OF TWELVE (12) MONTHS FROM DATE OF DELIVERY. THE FOREGOING TWELVE (12) MONTH WARRANTY SHALL NOT BE EXTENDED OR CHANGED BY THK FURNISHING ANY REPLACEMENTS, ADDITIONS, ATTACHMENTS, ACCESSORIES OR REPAIRS TO THE PRODUCT SUBSEQUENT TO THE DATE OF DELIVERY OR ACCEPTANCE. THE FOREGOING WARRANTY IS THE SOLE AND EXCLUSIVE WARRANTY OF THK REGARDING THE PRODUCT.

**DISCLAIMER OF OTHER WARRANTIES:** OTHER THAN THE FOREGOING WARRANTY, THERE ARE NO EXPRESS OR IMPLIED WARRANTIES OR ANY AFFIRMATIONS OF FACT OR PROMISES BY THK WITH RESPECT TO THE PRODUCT. THK DISCLAIMS ANY WARRANTIES, EXPRESS, IMPLIED OR STATUTORY, NOT SPECIFICALLY SET FORTH ABOVE. WITHOUT LIMITING THE GENERALITY OF THE FOREGOING, THK EXPRESSLY DISCLAIMS ANY IMPLIED WARRANTIES OF MERCHANTABILITY, FITNESS FOR ANY PARTICULAR PURPOSE, INFRINGEMENT OR ANY REPRESENTATIONS OF FACT OR QUALITY NOT EXPRESSLY SET FORTH HEREIN.

**LIMITATION OF LIABILITY AND REMEDIES:** THK'S SOLE RESPONSIBILITY AND LIABILITY INCURRED AS A RESULT OF THE SALE AND/OR USE OF THE PRODUCT, AND THE PURCHASER'S EXCLUSIVE REMEDY AGAINST THK UNDER ANY WARRANTY SHALL BE LIMITED TO THE REPAIR OR REPLACEMENT, AT THK'S OPTION, OF PRODUCT COMPONENTS NOT CONFORMING TO THE WARRANTY. THE TOTAL LIABILITY OF THK SHALL IN NO EVENT EXCEED THE AMOUNT ACTUALLY PAID TO THK BY PURCHASER WITH RESPECT TO THE PRODUCT. THIS LIMITATION OF REMEDY IS INTENDED BY THE PARTIES TO SURVIVE EVEN IF THE REMEDY IS CLAIMED TO HAVE FAILED OF ITS ESSENTIAL PURPOSE. PURCHASER'S FULL AND COMPLETE PERFORMANCE OF ALL OBLIGATIONS OF PURCHASER RECITED IN THIS AGREEMENT IS A CONDITION PRECEDENT TO THK'S WARRANTY OBLIGATIONS AND LIABILITIES HEREIN.

**PURCHASER'S DAMAGES AND LIMITATIONS:** IN NO EVENT SHALL THK BE LIABLE TO PURCHASER, ITS ASSIGNS OR AGENTS, FOR ECONOMIC LOSS, INCIDENTAL OR CONSEQUENTIAL DAMAGES, IN CONTRACT OR IN TORT, INCLUDING BUT NOT LIMITED TO, ANY DAMAGES FOR LOST PROFITS, DOWN-TIME, LOST PRODUCTION, FAILURE TO MEET PURCHASER'S SALES CONTRACTS, OR DEFECTS IN PURCHASER'S MATERIALS OR WORKMANSHIP ARISING DIRECTLY OR INDIRECTLY FROM THE USE OF THE PRODUCT.

## DISCLAIMER

This Catalog provides basic information relating to THK linear motion and related products. The Catalog, including all information, charts, formulas, factors, accuracy standards, tolerances and application recommendations contained herein, is only a starting point for the customer's selection of appropriate products, and may not apply in all intended applications. The Catalog is not a substitute for a proper application analysis conducted by an experienced, knowledgeable design engineer. Product selection should be based upon your specific application needs and conditions, which will vary greatly depending on many factors. No specific product application should be based solely on the information contained in this Catalog. All purchases of THK Products are subject to the limited warranty offered by THK Co., Ltd, for itself and on behalf of its related companies and subsidiaries. Customers should confirm independently that a contemplated application is safe, appropriate and effective.

"All trademarks used in this Catalog are registered trademarks in the Country of Japan. If there is any question as to the validity of such trademarks outside of Japan, an inquiry should be made in that particular country."

---



# Technical Support Site

The THK Technical Support Site lets you access product information and technical support online. You will also find a search feature for locating desired products and a calculation feature for calculating service life. 2D-CAD and 3D-CAD data are also downloadable.

<http://www.thk.com/> or

## Top page of the Global site



<http://www.thk.com/>

## Technical Support Site

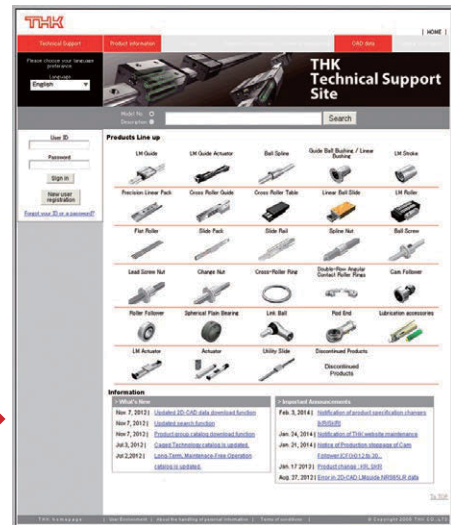

<https://tech.thk.com/>

### Product Information

Search by model number or description. Also contains detailed product specifications according to model number.

### Technical Information

Contains technical information, from application examples to research papers.  
(\* To use this service, you must log in first.)

### Technical Calculation

Rated life (life time) can be calculated simply by entering model number, application criteria, etc.  
(\* To use this service, you must log in first.)

### CAD Data

You can acquire 2D-CAD data (DXF files) on approximately 4,000 items, or 3D-CAD data according to specifications from rail lengths to installation of option items.  
(\* To use this service, you must log in first.)

### Catalog Information

Order any of a variety of catalogs. You can also view in PDF format.  
(\* To use this service, you must log in first.)

### FAQ

Contains frequently asked questions.

# Linear Motion System DVD Catalog

Linear Motion System DVD Catalog is also available. Please contact THK, distributors or other purchasable contacts in your area for a request.



Please choose your preferred language.

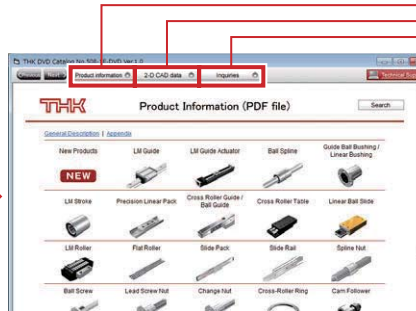

Displays product information.

Enables you to use 2-D CAD data (DXF files).

Enables you to use 3-D CAD data.

## Product information (PDF file)

Contains catalog PDF data for new products and mechatronic products, in addition to the product information contained in the General Catalog.

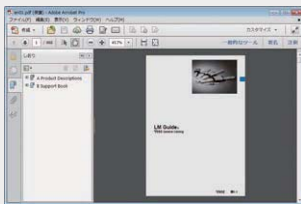

## 2-D CAD data (DXF file)

You can use 2-D CAD data (DXF files) for approximately 4,000 products.

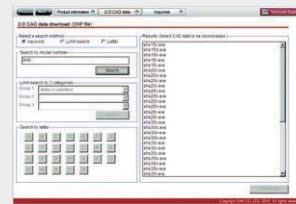

## 3-D CAD data generation program

This function enables you to use 3-D CAD data.

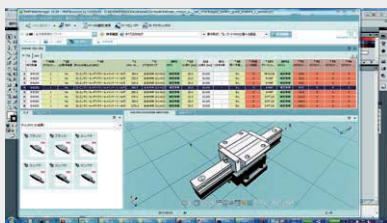

## Selectable options and specifications

By combining product model numbers and options, you can generate 3-D CAD data tailored to your specifications.

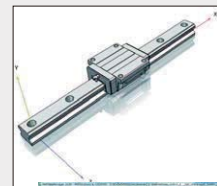

## 3-D CAD and 2-D CAD data

You can then quickly and easily import the generated 3-D CAD data into your 3-D CAD software. 2-D CAD data can also be generated with this program.

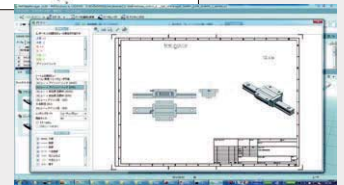

CAD type	Formats supported
3-D CAD	DXF 3D / IGES / SAT / STEP Solidworks 2013, 2014, 2015, Macro 3D
2-D CAD	DXF Version 2004-2015