

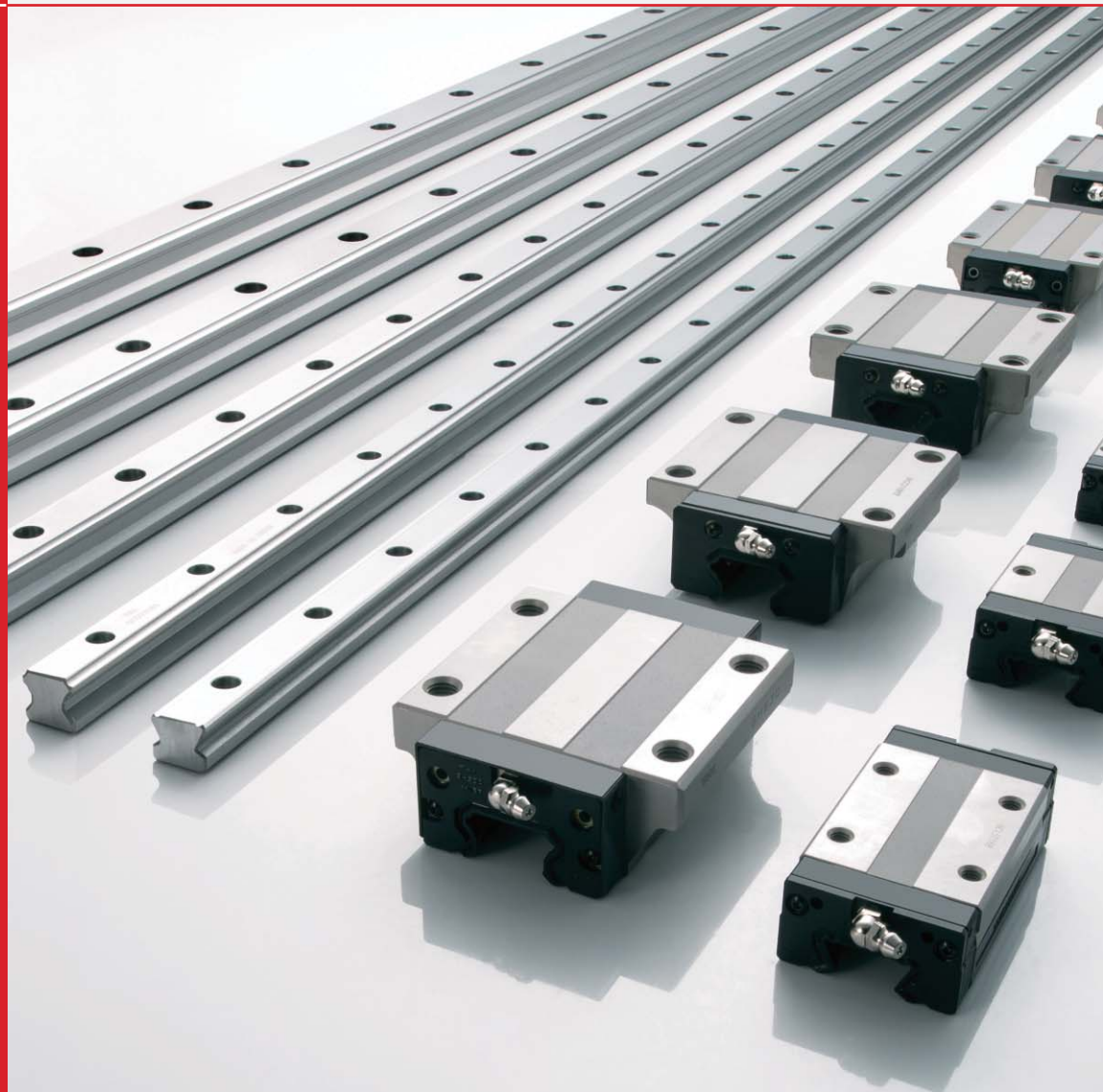

GK series

LM Guide

**Rails and Blocks are individually Stocked
for Easy/Fast Interchangeability**



THK CO., LTD.
TOKYO, JAPAN

CAT. NO. 410-3E

Features of the LM Guide

- 1 Large Permissible Load
- 2 Ideal 4-column Circular-arc Groove, 2-point Contact Structure
- 3 Superior Error-absorbing Capability with DF Structure
- 4 Significant Energy-saving Effect



Large Permissible Load

When comparing a type where the ball contacts R-shaped grooves whose diameters are approximate to the ball diameter (LM Guide) to a type where the ball contacts on a surface (Linear Bushing), the LM Guide has the load capacity of 13 times larger per ball under the same ball diameter condition. As long as the load capacity is identical, using the LM Guide can provide a significant downsizing.

| Fig.1 | Load Capacity of a Single Ball

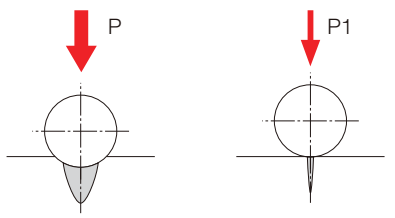

R-shaped groove **Plain surface**

| Table 1 | Load Capacity of a Single Ball (P), (P1)

	R-shaped groove (P)	Plain surface (P1)	P/P1
ø3.175(1/8")	0.90 kN	0.07 kN	13
ø4.763(3/16")	2.03 kN	0.16 kN	13
ø6.350(1/4")	3.61 kN	0.28 kN	13
ø7.938(5/16")	5.64 kN	0.44 kN	13
ø11.906(15/32")	12.68 kN	0.98 kN	13

Since service life is proportional to the cube of the permissible load, a service life that is approximately 2,200 times longer can be realized.

When comparing the LM Guide to the Linear Bushing whose basic dynamic load rating value is approximate mutually, the cross-sectional area is downsized to $34 \times 24 / 170 \times 165 \div 1/34$.

| Fig.2 | Comparison of the LM Guide with the Linear Bushing

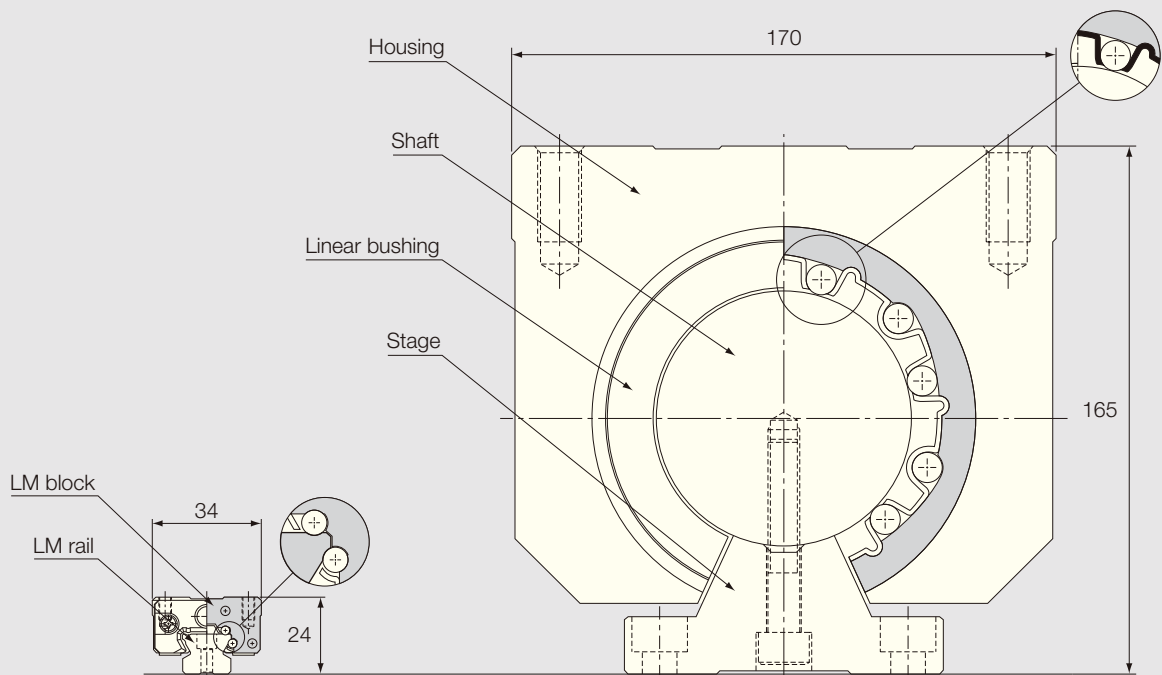

LM Guide Model SR15W
Basic dynamic load rating: 13.8kN

Linear Bushing Model LM80GA OP
Basic dynamic load rating: 7.35kN

Ideal 4-column Circular-arc Groove, 2-point Contact Structure

A 4-column Circular-arc Groove, 2-point Contact Structure adopted in the LM Guide is an ideal contact structure which optimizes the performance of ball raceways.

With a column circular-arc groove, the Guide is extremely less slippery (differential slip), which is generated during the ball movement and can move comfortably.

Comparison of Properties of the LM Guide and a Similar Product

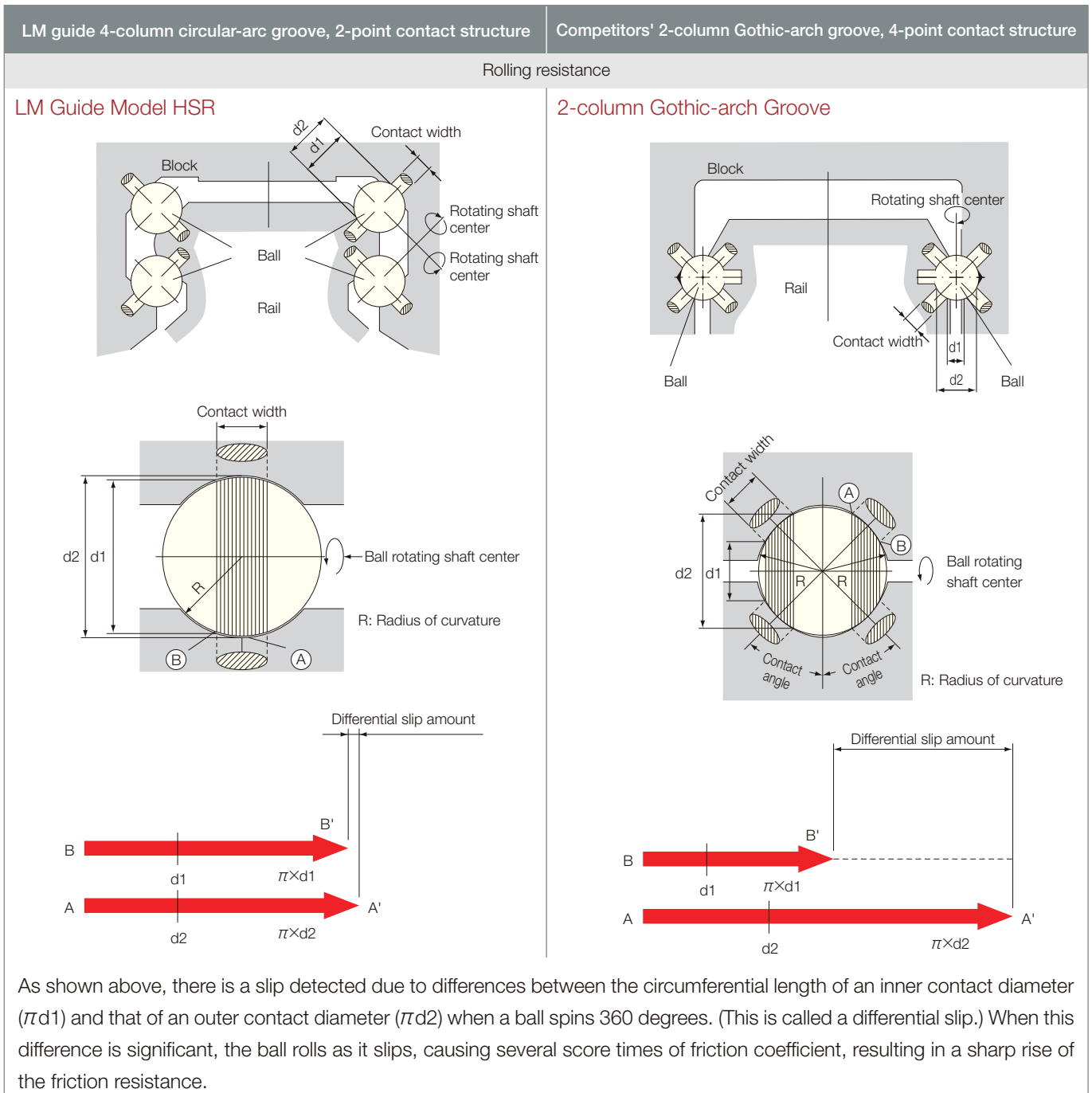

LM guide 4-column circular-arc groove, 2-point contact structure	Competitors' 2-column Gothic-arch groove, 4-point contact structure
Movement	
A 2-point contact can be attained toward the load direction when preloaded or loaded, causing less differential slip but favorable rolling motion.	As the differential slip is large on the ball contact surface, the ball rolls as it slips, causing unfavorable rolling motion. In addition, a significant friction is generated under conditions shown below, and such abnormal wear shortens the service life of the Guide. (1) When the Guide is preloaded, (2) When lateral load is applied, (3) When parallelism is poor when mounting 2 or more rails, or (4) When spinning is detected.
Service life	
The Gothic-arch groove, when compared to the circular-arc groove, has approximately 50% decreased load rating and its service life will be reduced to 87.5%.	
Mounting-Surface Accuracy	
An ideal 2-point contact structure with an appropriate contact angle given to a 4-column circular-arc groove helps balls to deform elastically and shift the contact point, so that some errors on the mounting surface are absorbed inside the LM blocks, allowing for a reasonable and smooth movement.	With a Gothic-arch groove, the elastic deformation of balls is inhibited by the balls contacting at four points, disabling the shift of the contact point (inability of automatic adjustment), so that errors on the mounting surface or accuracy error of an orbit stand cannot be absorbed and a smooth movement cannot be attained.
Rigidity	
With the two-point contact, even if a relatively large preload is applied, the rolling resistance does not abnormally increase and high rigidity is obtained.	Since differential slip occurs due to the four-point contact, a sufficient preload cannot be applied and high rigidity cannot be obtained.

Accuracy Error of the Mounting Surface and Test Data on Rolling Resistance

The following are test data obtained by comparing an LM Guide having a four-raceway, circular-arc groove, two-point contact structure and a product having a two-row, Gothic-arch, four-point contact structure.

Sample	Conditions
(1) LM Guide SR30W (radial type) 2 sets HSR35A (4-way equal-load type) 2 sets	Radial clearance: $\pm 0 \mu\text{m}$ Without seal Load: table mass of 30 kg
(2) Two-row Gothic-arch groove product Type with dimensions similar to HSR30 2 sets	

Preload and rolling resistance

When a preload is applied, the rolling resistance of the Gothic-arch groove product steeply increases and differential slip occurs. Even under a preload, the rolling resistance of the LM Guide does not increase.

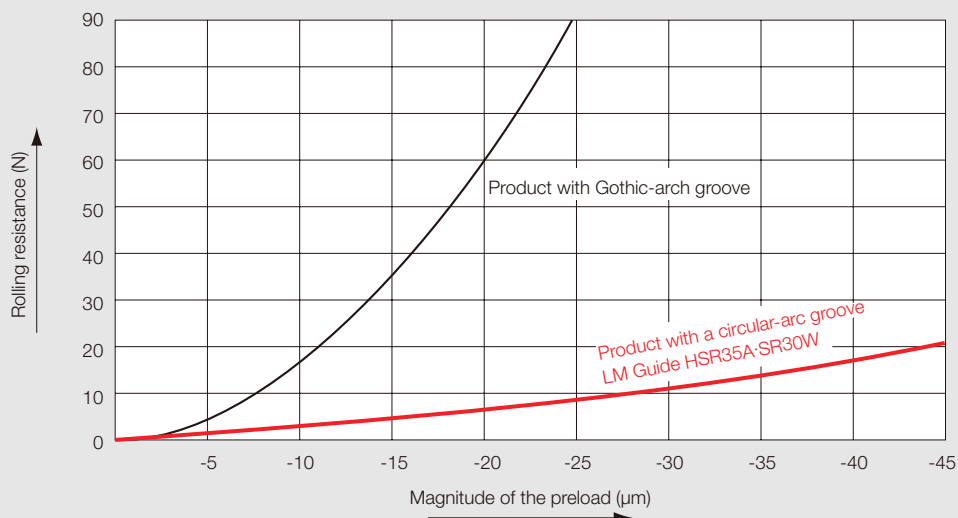

Superior Error-absorbing Capability with DF Structure

The LM Guide has a self-aligning capability as it has a contact structure similar to the front-to-front configuration of an angular ball bearing.

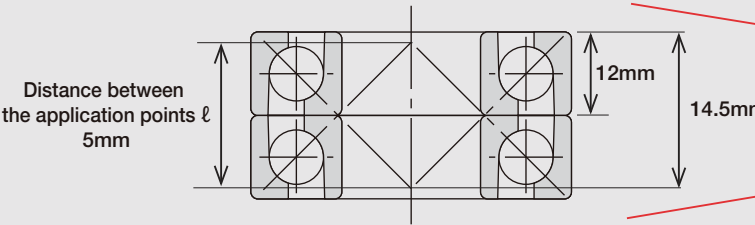
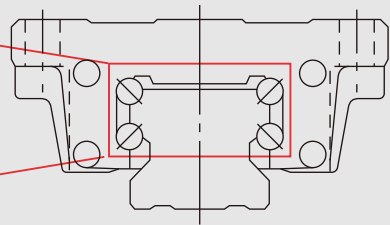
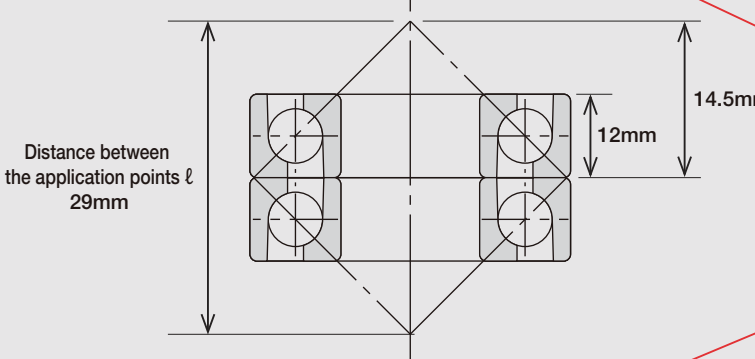
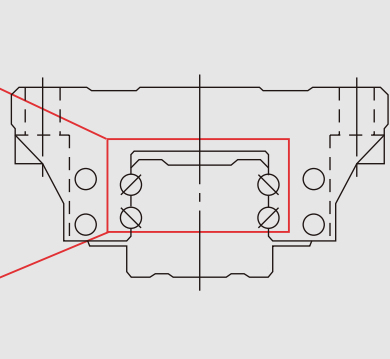
 <p>Distance between the application points ℓ 5mm</p>	
<p>Front-to-Front Angular Ball Bearing (DF Structure)</p> <p>Since the distance between the application points ℓ is small, a large permissible tilt can be secured. (High self-aligning capability)</p>	<p>DF Structure (LM Guide)</p> <p>Internal structure not easily affected by the mounting surface error</p>
 <p>Distance between the application points ℓ 29mm</p>	
<p>Back-to-Back Angular Ball Bearing (DB Structure)</p> <p>Since the distance between the application points is large, the permissible tilt is small.</p>	<p>DB Structure (Competitor's Similar Product)</p> <p>Requires high mounting surface accuracy</p>

The linear guide installed flat must have the self-aligning capability as moments (M) are observed due to deviation in flatness, level error, or warped table.

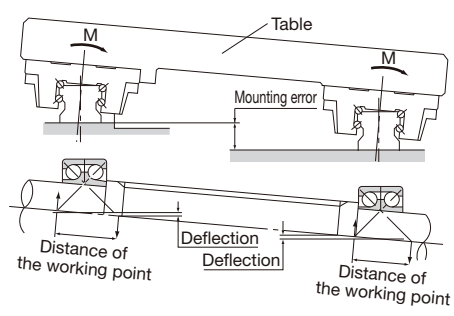
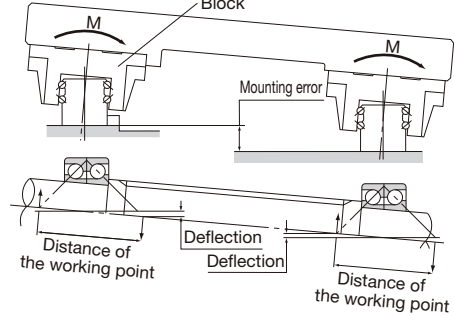
LM Guide Model HSR	Competitor's similar product
	
<p>Since the distance between the application points of the bearing is small, the internal load generated from a mounting error is small, causing the Guide to move comfortably.</p>	<p>Since the distance between the application points of the bearing is large, the internal load generated from a mounting error is large and the self-aligning capability is small.</p> <p>For a competitor's similar linear guide with back-to-back configuration, the internal load against the blocks is about six times as large as that of a front-to-front configuration, and its service life is shortened significantly when there is deviation in flatness or a warped table. In addition, the slide resistance changes drastically.</p>

Features of the LM Guide 4

Significant Energy-saving Effect

Table 2 shows the energy consumption of a large grinder using a sliding guide and the LM Guide. The LM Guide provides more than 10 times stronger energy saving effect.

| Table 2 | Comparison Data of Sliding and Rolling Properties

Mechanical specification		
Model	Single-axis surface grinder (Sliding guide)	Triple-axis surface grinder (Rolling guide)
Length × Width	13m×3.2m	12.6m×2.6m
Gross mass	17000kg	16000kg
Table mass	5000kg	5000kg
Grinding area	0.7m×5m	0.7m×5m
Table guide unit	Slip by V-V guide	Roll by assembled LM Guide

Table driving specification			Ratio
Motor used	38.05kW	3.7kW	10.3
Driving hydraulic pressure	Bore diameter Ø160×1.2MPa	Bore diameter Ø65×0.7MPa	-
Thrust	23600N	2270N	10.4
Power consumption	38kWH	3.7kWH	10.3
Driving hydraulic pressure consumption	400ℓ/year	250ℓ/year	1.6
Lubricant consumption	60ℓ/year (lubricant)	3.6ℓ/year (grease)	16.7

Comparison of used lubricant
Annual total lubricant quantity used for machine tools (Machining Center)
(Total travel distance 3000km/year)

Machine using a conventional LM Guide
Total lubricant quantity (using air oil mist)

Oil can 20L×5 + air259dm³/min

Caged Ball
Machine using an LM Guide
Total lubricant quantity (using grease)

Initial greasing 260cc
Lubrication unit, piping Not required
Air Not required
Used 2/3 of grease 400cc

Introduction of Caged Ball LM Guide

Structure and Features of the Caged Ball LM Guide

With the Caged Ball LM Guide, balls circulate being retained by the ball cage, thus to eliminate metallic contact between the balls. When balls enter or leave the loaded area of the LM block, the ball circulation part of the unloaded area of the LM block is formed with resin, which prevents metallic contact between the balls and LM block.

Therefore, the Caged Ball LM Guide reduces noise and improves the quality of the operation sound.

In addition, the grease retained in the ball circulation path and the ball cage (grease pocket) forms a very thin oil film on the ball surface by being caught by rotation of the balls.

This constantly keeps good the lubrication condition of the contact surface between each ball and the ball cage.

In addition, since the contact surface between each ball and the ball cage is a large surface contact, the surface pressure decreases significantly, which reduces heat generation and deterioration of lubricant and prolongs the service life.

The Caged Ball LM Guide can realize long service life and long-term maintenance-free operation and improve the work environment.

Caged Ball LM Guide GK Series include three types; Models SHS, SSR and SRS, which are made available.

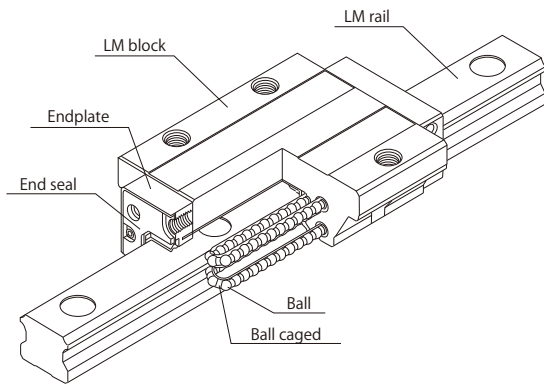

Structural Drawing of the Caged Ball LM Guide Model SHS

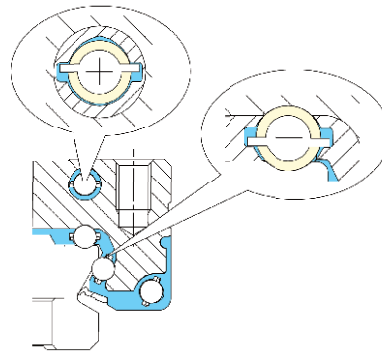

Cross section of the Caged Ball LM Guide Model SSR

Without caged ball

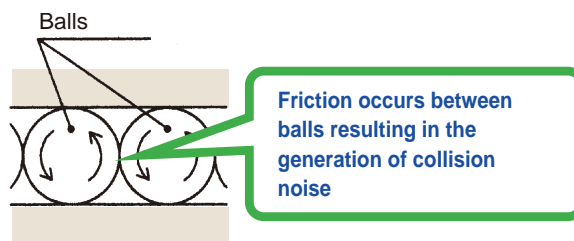
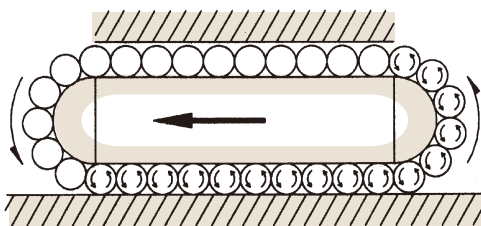

With caged ball

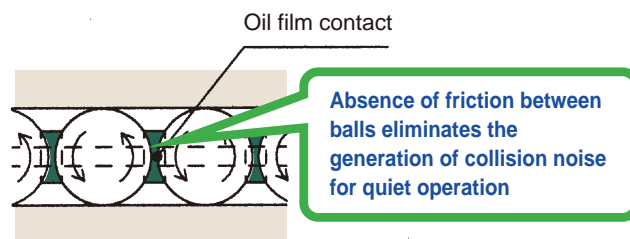
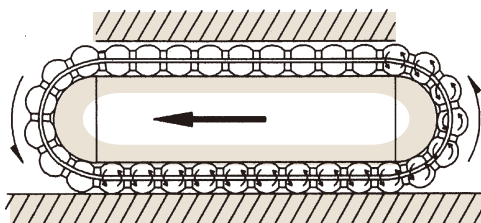

Advantages of the Ball Cage Technology

- The absence of friction between balls, together with increased grease retention, achieves long service life and long-term maintenance-free (lubrication-free) operation.
- The absence of ball-to-ball collision achieves low noise and acceptable running sound.
- The absence of friction between balls achieves low heat generation and high speed operation.
- The circulation of lines of evenly spaced balls ensures smooth ball rotation.
- The absence of friction between balls allows high grease retention and low dust generation.

Structure and Features of Equipment Using the Caged Ball LM Guide

- Long-term maintenance-free (lubrication-free) operation
Decrease in the number of times of equipment maintenance work enables reduction in the maintenance costs.
- Improvement in the productivity
This enables high-speed usage and thus reduction in the tact time.
- Downsizing of equipment
The basic dynamic load rating is equivalent to that of one size larger full-component LM Guide, which enables downsizing of equipment and space-saving.
- The ball cage helps to align balls evenly and circulate, providing a smoother operation.
- Improvement in the work environment
This reduces the noise of equipment and thus scatter of the grease.

Test Data of the Caged Ball LM Guide

•Data on Long Service Life and Long-term Maintenance-free Operation

Use of a ball cage eliminates friction between balls and increases grease retention, thus to achieve long service life and long-term maintenance-free operation.

[Conditions]

Model No.: SHS25/HSR25

Speed: 60m/min

Stroke: 350mm

Acceleration: 9.8m/s²

Orientation: Horizontal

Load: Caged Ball LM Guide

Model SHS: 11.1kN

Conventional Full-ball Type

Model HSR: 9.8kN

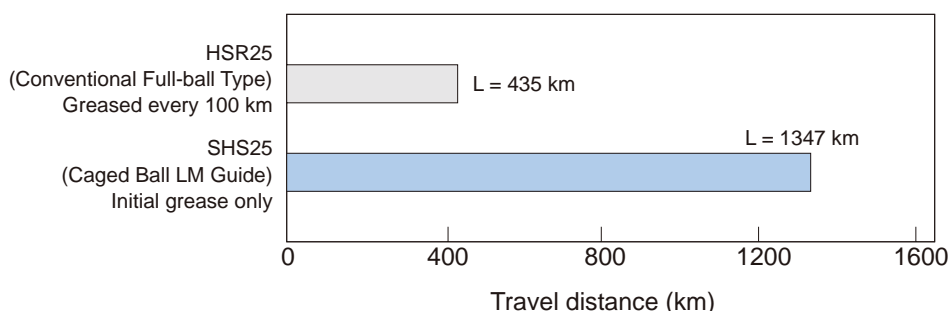

GLOBAL STANDARD PRODUCTS

LM Guide **GK series**

Rails and Blocks are individually Stocked for Easy/Fast Interchangeability.



Model Line up

HSR Global Standard size



A/LA
The flange of its LM block has tapped holes.

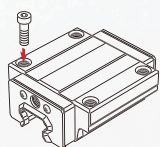

B/LB
The flange of the LM block has through holes. Used in places where the table cannot have through holes for mounting bolts.

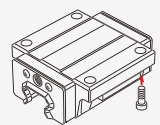

R/LR
Having a smaller LM block width (W) and tapped holes, this model is optimal for compact design.

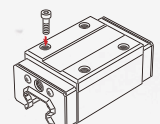

SHS Global Standard size / Long-term maintenance free

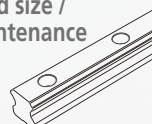

C/LC
The flange of the LM block has tapped holes. Can be mounted from the top or the bottom.

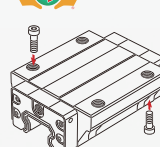

V/LV
With this type, the LM block has a smaller width (W) and tapped holes.

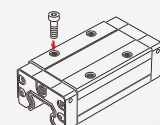

R/LR
It succeeds the height dimension of full-ball type LM Guide HSR-R.

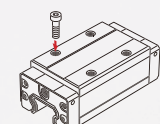

SR Radial type

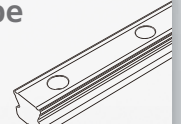

TB
The LM block has the same height as model SR-W and can be mounted from the bottom.

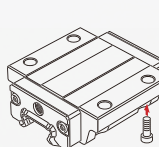

W
With this type, the LM block has a smaller width (W) and tapped holes.

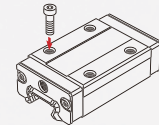

V
A space-saving type whose LM block has the same cross-sectional shape as model SR-W, but has a smaller overall LM block length (L).

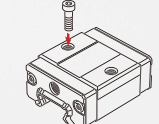

SR and SSR share a common rail.



All for smooth, accurate "movement."

To make an analogy...it is like the hands of a great pianist. THK's original technology is behind the smooth and silent movement of the "Linear Motion System". The rotating movement of "rolling" uses bearings that have been in use in products for over 100 years. However, the world's first "rolling" in linear movement was achieved in 1972, when THK developed the "Linear Motion System." Since then, all THK technologies have been employed for the only purpose of providing smoothness and accuracy to "movement" of all mechanisms.

SSR Radial type / Long-term maintenance free

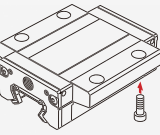

XTB
Since the LM block can be mounted from the bottom, this type is optimal for applications where through holes for mounting bolts cannot be drilled on the table.

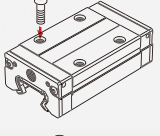

XW
With this type, the LM block has a smaller width (W) and tapped holes.

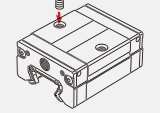

XV
This type has the same cross-sectional shape as SSR-XW but has a shorter overall LM block length (L).

SRS-G Miniature Type

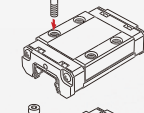

GM
With this type, the LM block has a smaller width (W) and tapped holes.

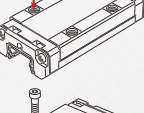

GN
The LM block has the same cross-sectional shape as model SRS-GM, but has a longer overall LM block length (L) and a greater rated load and permissible moment.

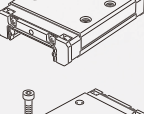

WGM
This type has a greater overall LM block length (L), broader width (W) and greater rated load and permissible moment than SRS-GM.



WGN
The LM block has the same cross-sectional shape as model SRS-WGM, but has an even longer overall LM block length (L) and a greater rated load and permissible moment.

SRS Miniature Type / Long-term maintenance free

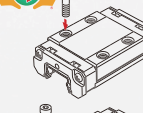

M
With this type, the LM block has a smaller width (W) and tapped holes.

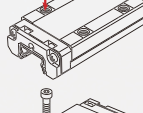

N
The LM block has the same cross-sectional shape as model SRS-M, but has a longer overall LM block length (L) and a greater rated load and permissible moment.

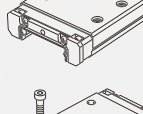

WM
This type has a greater overall LM block length (L), broader width (W) and greater rated load and permissible moment than SRS-M.

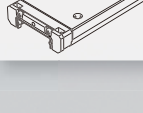

WN
The LM block has the same cross-sectional shape as model SRS-WM, but has an even longer overall LM block length (L) and a greater rated load and permissible moment.

SR and SSR share a common rail.

Selecting a Preload

LM Guide GK Series includes two radial clearance (preload).

The radial clearance greatly affects the running accuracy, load carrying capacity and rigidity of the LM Guide, it is important to select an appropriate radial clearance according to the application.

An appropriate radial clearance reduces vibrations and impact generated during the operation of the device and favorably affects the service life and the accuracy of the LM Guide.

Types of Radial Clearance

Radial clearance Preload	Radial clearance Symbol	Usage conditions
Normal clearance	No symbol	- Parts which you want to move slightly
Clearance C1 (Light preload)	C1	- Parts with little impact or vibration - Parts where LM Guide is used in a single-rail configuration - Parts which require light load and high accuracy

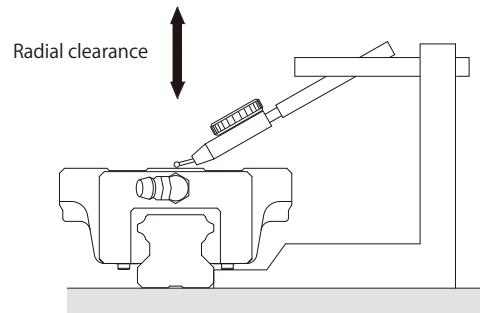

Model HSR

Unit: μm

Indication symbol	Normal	Light preload
Model No.	No Symbol	C1
15	-4 to +2	-12 to -4
20	-5 to +2	-14 to -5
25	-6 to +3	-16 to -6
30	-7 to +4	-19 to -7
35	-8 to +4	-22 to -8
45	-10 to +5	-25 to -10

Model SHS

Unit: μm

Indication symbol	Normal	Light preload
Model No.	No Symbol	C1
15	-5 to 0	-12 to -5
20	-6 to 0	-12 to -6
25	-8 to 0	-14 to -8
30	-9 to 0	-17 to -9
35	-11 to 0	-19 to -11
45	-12 to 0	-22 to -12

Model SR

Unit: μm

Indication symbol	Normal	Light preload
Model No.	No Symbol	C1
15	-4 to +2	-10 to -4
20	-5 to +2	-12 to -5
25	-6 to +3	-15 to -6
30	-7 to +4	-18 to -7
35	-8 to +4	-20 to -8

Model SSR

Unit: μm

Indication symbol	Normal	Light preload
Model No.	No Symbol	C1
15	-4 to +2	-10 to -4
20	-5 to +2	-12 to -5
25	-6 to +3	-15 to -6
30	-7 to +4	-18 to -7
35	-8 to +4	-20 to -8

Model SRS-G

Unit: μm

Indication symbol	Normal	Light preload
Model No.	No Symbol	C1
9	-2 to +2	-4 to 0
12	-3 to +3	-6 to 0
15	-5 to +5	-10 to 0

Model SRS

Unit: μm

Indication symbol	Normal	Light preload
Model No.	No Symbol	C1
9	-2 to +2	-4 to 0
12	-3 to +3	-6 to 0
15	-5 to +5	-10 to 0

Accuracy Standards

The accuracy grade of the LM Guide GK Series is specified in terms of running parallelism, dimensional tolerance for height and width, and height and width difference between a pair when 2 or more LM blocks are used on one rail or when 2 or more rails are mounted on the same plane.

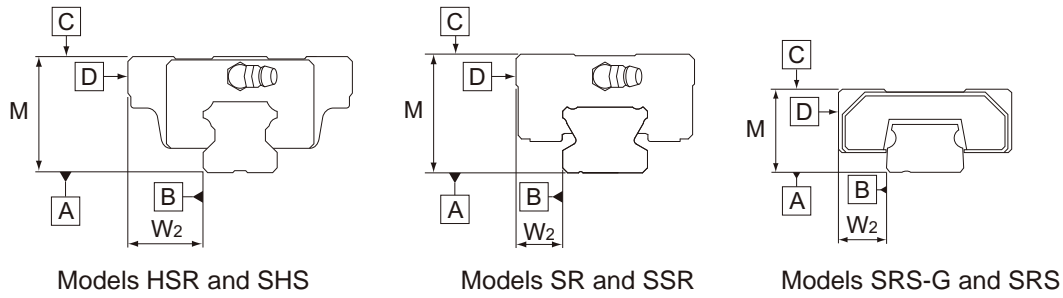

Running of Parallelism

It refers to the tolerance for parallelism between the LM block and the LM rail reference surface when the LM block travels the whole length of the LM rail with the LM rail secured on the reference surface using bolts.

Difference in height M

Indicates a difference between the minimum and maximum values of height (M) of each of the LM blocks used on the same plane in combination.

Difference in width W₂

Indicates a difference between the minimum and maximum values of the width (W₂) between each of the LM blocks, mounted on one LM rail in combination, and the LM rail.

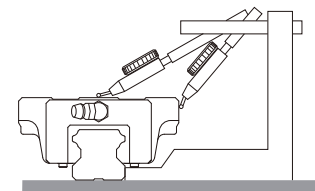

Running of Parallelism

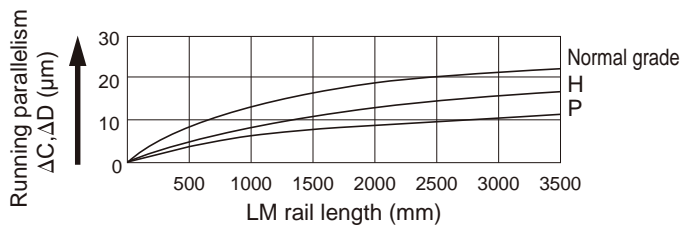

Fig.3 LM Rail Length and Running Parallelism (HSR/SR/SHS/SSR)

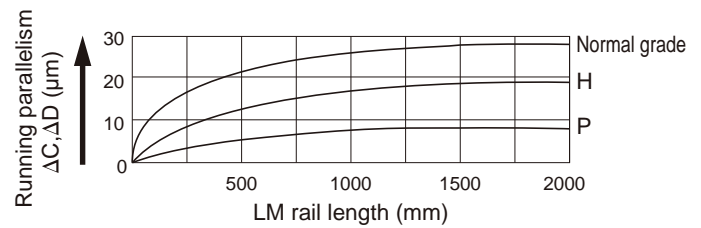

Fig.4 LM Rail Length and Running Parallelism (SRS-G/SRS)

Accuracy Standards (HSR/SR/SHS/SSR)

unit: mm

Model No.	Accuracy standards		Normal grade	High-accuracy grade	Precision grade	
	Item		(No Symbol)	H	P	
15 20	Dimensional tolerance in height M		±0.07	±0.03	0 -0.03	
		Difference in height M	On single axis	0.02	0.01	0.006
	On multiple axes		0.04	0.035	0.025	
	Dimensional tolerance in Width W ₂		±0.06	±0.03	0 -0.02	
		Difference in Width W ₂	0.02	0.01	0.006	
	Running parallelism of surface C against surface A		ΔC (as shown in Fig.3)			
	Running parallelism of surface D against surface B		ΔD (as shown in Fig.3)			
	25 30 35	Dimensional tolerance in height M		±0.08	±0.04	0 -0.04
			Difference in height M	On single axis	0.02	0.015
		On multiple axes		0.04	0.035	0.025
		Dimensional tolerance in Width W ₂		±0.07	±0.03	0 -0.03
			Difference in Width W ₂	0.025	0.015	0.007
Running parallelism of surface C against surface A		ΔC (as shown in Fig.3)				
Running parallelism of surface D against surface B		ΔD (as shown in Fig.3)				
45		Dimensional tolerance in height M		±0.08	±0.04	0 -0.05
			Difference in height M	On single axis	0.025	0.015
		On multiple axes		0.04	0.035	0.025
		Dimensional tolerance in Width W ₂		±0.07	±0.04	0 -0.04
			Difference in Width W ₂	0.03	0.015	0.007
	Running parallelism of surface C against surface A		ΔC (as shown in Fig.3)			
	Running parallelism of surface D against surface B		ΔD (as shown in Fig.3)			

Accuracy Standards (SRS-G/SRS)

unit: mm

Model No.	Accuracy standards		Normal grade	High-accuracy grade	Precision grade	
	Item		(No Symbol)	H	P	
SRS	9(G)M 9W(G)M 12(G)M	Dimensional tolerance in height M	±0.04	±0.02	±0.01	
		Difference in height M	0.05	0.03	0.02	
	12W(G)M 15(G)M 15W(G)M	Dimensional tolerance in Width W ₂	±0.04	±0.025	±0.015	
		Difference in Width W ₂	0.03	0.02	0.01	
	Running parallelism of surface C against surface A		ΔC (as shown in Fig.4)			
	Running parallelism of surface D against surface B		ΔD (as shown in Fig.4)			
	SRS	9(G)N 9W(G)N 12(G)N	Dimensional tolerance in height M	±0.06	±0.03	±0.015
			Difference in height M	0.05	0.03	0.02
		12W(G)N 15(G)N 15W(G)N	Dimensional tolerance in Width W ₂	±0.06	±0.04	±0.025
			Difference in Width W ₂	0.03	0.02	0.01
Running parallelism of surface C against surface A		ΔC (as shown in Fig.4)				
Running parallelism of surface D against surface B		ΔD (as shown in Fig.4)				

Model HSR

Models HSR-A and HSR-LA

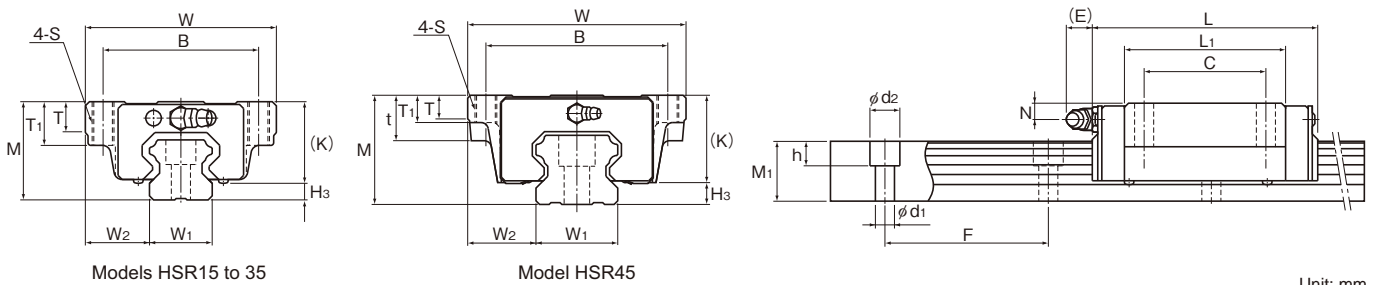

Unit: mm

Model No.	Outer dimensions			LM block dimensions										Grease nipple	H ₃	Basic load rating		Static permissible moment kN-m*					LM block kg
	Height	Width	Length	B	C	S	L ₁	t	T	T ₁	K	N	E			C	C ₀	M _A		M _B		M _C	
	M	W	L													kN	kN	1 block	Double blocks	1 block	Double blocks	1 block	
HSR 15A	24	47	56.6	38	30	M5	38.8	—	7	11	19.3	4.3	5.5	PB1021B	4.7	10.9	15.7	0.0945	0.527	0.0945	0.527	0.0998	0.2
HSR 20A HSR 20LA	30	63	74 90	53	40	M6	50.8 66.8	—	9.5	10	26	5	12	B-M6F	4	19.8 23.9	27.4 35.8	0.218 0.363	1.2 1.87	0.218 0.363	1.2 1.87	0.235 0.307	0.35 0.47
HSR 25A HSR 25LA	36	70	83.1 102.2	57	45	M8	59.5 78.6	—	11	16	30.5	6	12	B-M6F	5.5	27.6 35.2	36.4 51.6	0.324 0.627	1.8 3.04	0.324 0.627	1.8 3.04	0.366 0.518	0.59 0.75
HSR 30A HSR 30LA	42	90	98 120.6	72	52	M10	70.4 93	—	9	18	35	7	12	B-M6F	7	40.5 48.9	53.7 70.2	0.599 0.995	3.1 4.89	0.599 0.995	3.1 4.89	0.652 0.852	1.1 1.3
HSR 35A HSR 35LA	48	100	109.4 134.8	82	62	M10	80.4 105.8	—	12	21	40.5	8	12	B-M6F	7.5	53.9 65	70.2 91.7	0.895 1.49	4.51 7.13	0.895 1.49	4.51 7.13	1.05 1.37	1.6 2
HSR 45A HSR 45LA	60	120	139 170.8	100	80	M12	98 129.8	25	13	15	50	10	16	B-R1/8 (B-PT1/8)	10	82.2 100	101 135	1.5 2.59	8.37 13.4	1.5 2.59	8.37 13.4	1.94 2.6	2.8 3.3

*1 block: static permissible moment value with 1 LM block
Double blocks: static permissible moment value with 2 blocks closely contacting with each other

Models HSR-B and HSR-LB

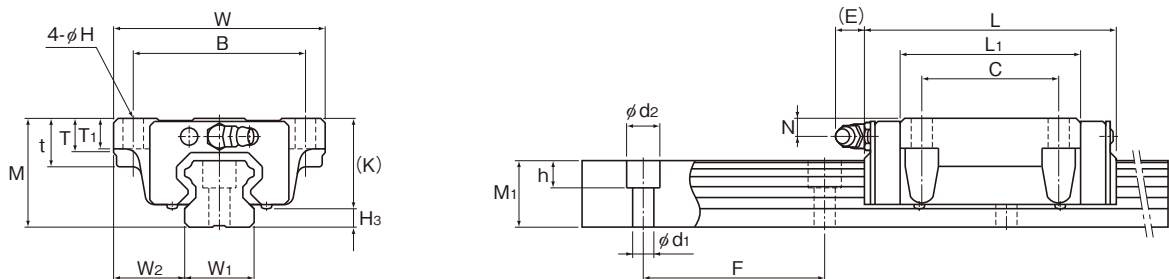

Unit: mm

Model No.	Outer dimensions			LM block dimensions										Grease nipple	H ₃	Basic load rating		Static permissible moment kN-m*					LM block kg
	Height	Width	Length	B	C	H	L ₁	t	T	T ₁	K	N	E			C	C ₀	M _A		M _B		M _C	
	M	W	L															kN	kN	1 block	Double blocks	1 block	
HSR 15B	24	47	56.6	38	30	4.5	38.8	11	7	7	19.3	4.3	5.5	PB1021B	4.7	10.9	15.7	0.0945	0.527	0.0945	0.527	0.0998	0.2
HSR 20B HSR 20LB	30	63	74 90	53	40	6	50.8 66.8	10	9.5	10	26	5	12	B-M6F	4	19.8 23.9	27.4 35.8	0.218 0.363	1.2 1.87	0.218 0.363	1.2 1.87	0.235 0.307	0.35 0.47
HSR 25B HSR 25LB	36	70	83.1 102.2	57	45	7	59.5 78.6	16	11	10	30.5	6	12	B-M6F	5.5	27.6 35.2	36.4 51.6	0.324 0.627	1.8 3.04	0.324 0.627	1.8 3.04	0.366 0.518	0.59 0.75
HSR 30B HSR 30LB	42	90	98 120.6	72	52	9	70.4 93	18	9	10	35	7	12	B-M6F	7	40.5 48.9	53.7 70.2	0.599 0.995	3.1 4.89	0.599 0.995	3.1 4.89	0.652 0.852	1.1 1.3
HSR 35B HSR 35LB	48	100	109.4 134.8	82	62	9	80.4 105.8	21	12	13	40.5	8	12	B-M6F	7.5	53.9 65	70.2 91.7	0.895 1.49	4.51 7.13	0.895 1.49	4.51 7.13	1.05 1.37	1.6 2
HSR 45B HSR 45LB	60	120	139 170.8	100	80	11	98 129.8	25	13	15	50	10	16	B-R1/8 (B-PT1/8)	10	82.2 100	101 135	1.5 2.59	8.37 13.4	1.5 2.59	8.37 13.4	1.94 2.6	2.8 3.3

*1 block: static permissible moment value with 1 LM block
Double blocks: static permissible moment value with 2 blocks closely contacting with each other

Models HSR-R and HSR-LR

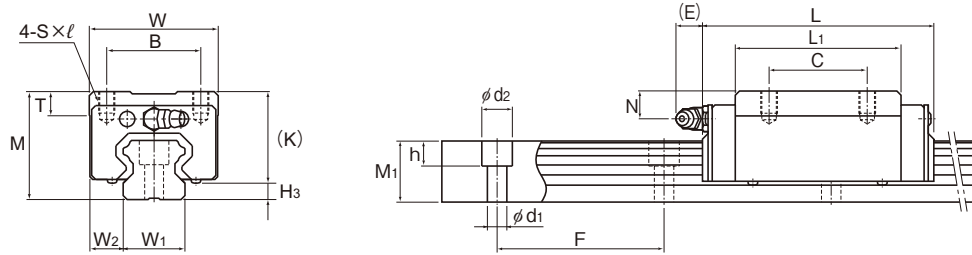

Unit: mm

Model No.	Outer dimensions			LM block dimensions									Grease nipple	H ₃	Basic load rating		Static permissible moment kN-m*					LM block kg
	Height	Width	Length	B	C	S × l	L ₁	T	K	N	E	C			C ₀	M _A		M _B		M _C		
	M	W	L													1 block	Double blocks	1 block	Double blocks	1 block		
HSR 15R	28	34	56.6	26	26	M4 × 5	38.8	6	23.3	8.3	5.5	PB1021B	4.7	10.9	15.7	0.0945	0.527	0.0945	0.527	0.0998	0.18	
HSR 20R HSR 20LR	30	44	74 90	32	36 50	M5 × 6	50.8 66.8	8	26	5	12	B-M6F	4	19.8 23.9	27.4 35.8	0.218 0.363	1.2	0.218 1.87	1.2	0.235 0.307	0.25 0.35	
HSR 25R HSR 25LR	40	48	83.1 102.2	35	35 50	M6 × 8	59.5 78.6	9	34.5	10	12	B-M6F	5.5	27.6 35.2	36.4 51.6	0.324 0.627	1.8	0.324 3.04	1.8	0.366 0.518	0.54 0.67	
HSR 30R HSR 30LR	45	60	98 120.6	40	40 60	M8 × 10	70.4 93	9	38	10	12	B-M6F	7	40.5 48.9	53.7 70.2	0.599 0.995	3.1	0.599 4.89	3.1	0.652 0.852	0.9 1.1	
HSR 35R HSR 35LR	55	70	109.4 134.8	50	50 72	M8 × 12	80.4 105.8	11.7	47.5	15	12	B-M6F	7.5	53.9 65	70.2 91.7	0.895 1.49	4.51	0.895 7.13	4.51	1.05 1.37	1.5 2	
HSR 45R HSR 45LR	70	86	139 170.8	60	60 80	M10 × 17	98 129.8	15	60	20	16	B-R1/8 (B-PT1/8)	10	82.2 100	101 135	1.5 2.59	8.37	1.5 2.59	8.37	1.94 2.6	2.6 3.1	

*1 block: static permissible moment value with 1 LM block
 Double blocks: static permissible moment value with 2 blocks closely contacting with each other

HSR LM RAIL

LM rail dimensions (Model HSR)

Unit: mm

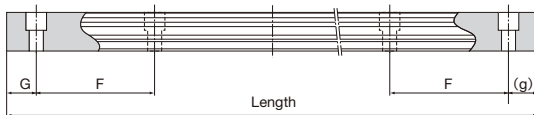

Model No.	LM rail dimensions							Length (G,g)	Mass LM rail kg/m
	Width	Height	Pitch	Length					
	W ₁ ±0.05			W ₂	M ₁	F	d ₁ × d ₂ × h		
HSR 15	15	16	15	60	4.5 × 7.5 × 5.3	3000(20,40)	—	1.5	
HSR 20	20	21.5	18	60	6 × 9.5 × 8.5	3000(20,40)	4540(20,20)	2.3	
HSR 25	23	23.5	22	60	7 × 11 × 9	3000(20,40)	4540(20,20)	3.3	
HSR 30	28	31	26	80	9 × 14 × 12	3000(20,20)	4520(20,20)	4.8	
HSR 35	34	33	29	80	9 × 14 × 12	3000(20,20)	4520(20,20)	6.6	
HSR 45	45	37.5	38	105	14 × 20 × 17	3000(20,40)	4560(22.5,22.5)	11	

Please contact the LM rail length you need to your dealer

Model number coding

HSR25 B 1 SS C1 H (GK) BLOCK

Model number
Type of LM block

GK series must be "1".

Contamination protection accessory symbol
 SS : With end seal + side seal
 GK series must be "SS".

GK series
LM block symbol

Accuracy Grade
 Normal grade (No Symbol)
 High grade (H)
 Precision grade (P)

Radial clearance symbol
 Normal (No symbol)
 Light preload (C1)

HSR25 - 3000L H (GK) RAIL

Model number
LM rail length (in mm)

GK series
LM rail symbol

Accuracy Grade
 Normal grade (No Symbol)
 High grade (H)
 Precision grade (P)

Models SHS-C and SHS-LC

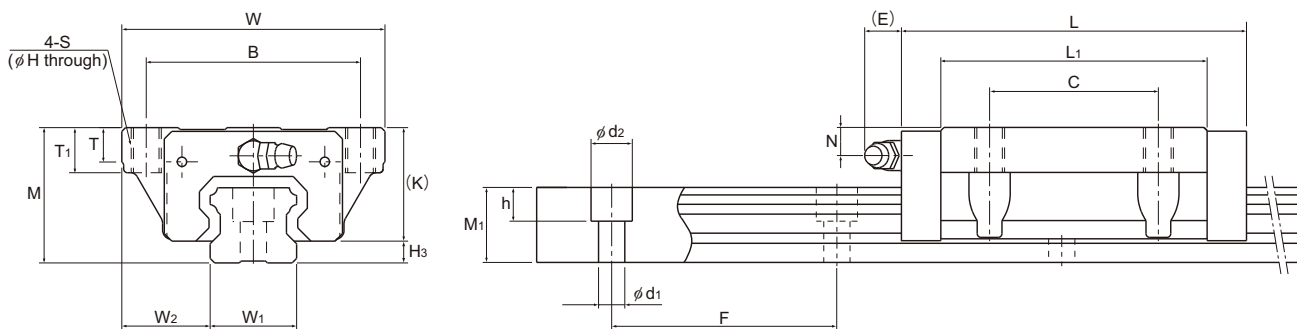

Unit: mm

Model No.	Outer dimensions			LM block dimensions											Grease nipple	H ₃	Basic load rating		Static permissible moment kN-m*					LM block kg
	Height M	Width W	Length L	B	C	S	H	L ₁	T	T ₁	K	N	E	C			C ₀	M _A		M _B		M _C		
																		1 block	Double blocks	1 block	Double blocks	1 block		
SHS 15C SHS 15LC	24	47	64.4 79.4	38	30	M5	4.4	48 63	5.9	8	21	5.5	5.5	PB1021B	3	14.2 17.2	24.2 31.9	0.175 0.296	0.898 1.43	0.175 0.296	0.898 1.43	0.16 0.212	0.23 0.29	
SHS 20C SHS 20LC	30	63	79 98	53	40	M6	5.4	59 78	7.2	10	25.4	6.5	12	B-M6F	4.6	22.3 28.1	38.4 50.3	0.334 0.568	1.75 2.8	0.334 0.568	1.75 2.8	0.361 0.473	0.46 0.61	
SHS 25C SHS 25LC	36	70	92 109	57	45	M8	6.8	71 88	9.1	12	30.2	7.5	12	B-M6F	5.8	31.7 36.8	52.4 64.7	0.566 0.848	2.75 3.98	0.566 0.848	2.75 3.98	0.563 0.696	0.72 0.89	
SHS 30C SHS 30LC	42	90	106 131	72	52	M10	8.5	80 105	11.5	15	35	8	12	B-M6F	7	44.8 54.2	66.6 88.8	0.786 1.36	4.08 6.6	0.786 1.36	4.08 6.6	0.865 1.15	1.34 1.66	
SHS 35C SHS 35LC	48	100	122 152	82	62	M10	8.5	93 123	11.5	15	40.5	8	12	B-M6F	7.5	62.3 72.9	96.6 127	1.38 2.34	6.76 10.9	1.38 2.34	6.76 10.9	1.53 2.01	1.9 2.54	
SHS 45C SHS 45LC	60	120	140 174	100	80	M12	10.5	106 140	14.1	18	51.1	10.5	16	B-R1/8 (B-PT1/8)	8.9	82.8 100	126 166	2.05 3.46	10.1 16.3	2.05 3.46	10.1 16.3	2.68 3.53	3.24 4.19	

*1 block: static permissible moment value with 1 LM block

Double blocks: static permissible moment value with 2 blocks closely contacting with each other

Models SHS-V and SHS-LV

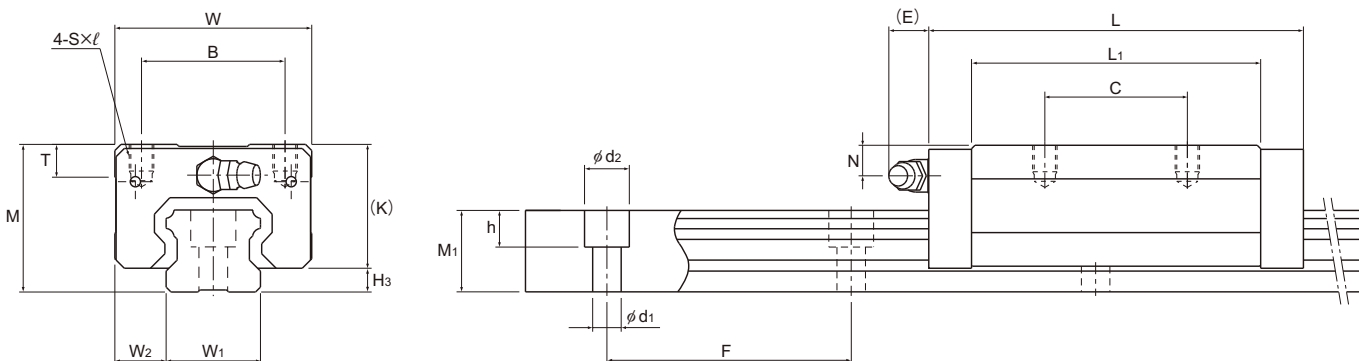

Unit: mm

Model No.	Outer dimensions			LM block dimensions											Grease nipple	H ₃	Basic load rating		Static permissible moment kN-m*					LM block kg
	Height M	Width W	Length L	B	C	S×ℓ	L ₁	T	K	N	E	C	C ₀	M _A			M _B		M _C					
														1 block			Double blocks	1 block	Double blocks	1 block				
SHS 15V SHS 15LV	24	34	64.4 79.4	26	26	M4×4	48 63	5.9	21	5.5	5.5	PB1021B	3	14.2 17.2	24.2 31.9	0.175 0.296	0.898 1.43	0.175 0.296	0.898 1.43	0.16 0.212	0.19 0.22			
SHS 20V SHS 20LV	30	44	79 98	32	36	M5×5	59 78	8	25.4	6.5	12	B-M6F	4.6	22.3 28.1	38.4 50.3	0.334 0.568	1.75 2.8	0.334 0.568	1.75 2.8	0.361 0.473	0.35 0.46			
SHS 25V SHS 25LV	36	48	92 109	35	35	M6×6.5	71 88	8	30.2	7.5	12	B-M6F	5.8	31.7 36.8	52.4 64.7	0.566 0.848	2.75 3.98	0.566 0.848	2.75 3.98	0.563 0.696	0.54 0.67			
SHS 30V SHS 30LV	42	60	106 131	40	40	M8×8	80 105	8	35	8	12	B-M6F	7	44.8 54.2	66.6 88.8	0.786 1.36	4.08 6.6	0.786 1.36	4.08 6.6	0.865 1.15	0.94 1.16			
SHS 35V SHS 35LV	48	70	122 152	50	50	M8×10	93 123	14.7	40.5	8	12	B-M6F	7.5	62.3 72.9	96.6 127	1.38 2.34	6.76 10.9	1.38 2.34	6.76 10.9	1.53 2.01	1.4 1.84			
SHS 45V SHS 45LV	60	86	140 174	60	60	M10×15	106 140	14.9	51.1	10.5	16	B-R1/8 (B-PT1/8)	8.9	82.8 100	126 166	2.05 3.46	10.1 16.3	2.05 3.46	10.1 16.3	2.68 3.53	2.54 3.19			

*1 block: static permissible moment value with 1 LM block

Double blocks: static permissible moment value with 2 blocks closely contacting with each other

Models SHS-R and SHS-LR

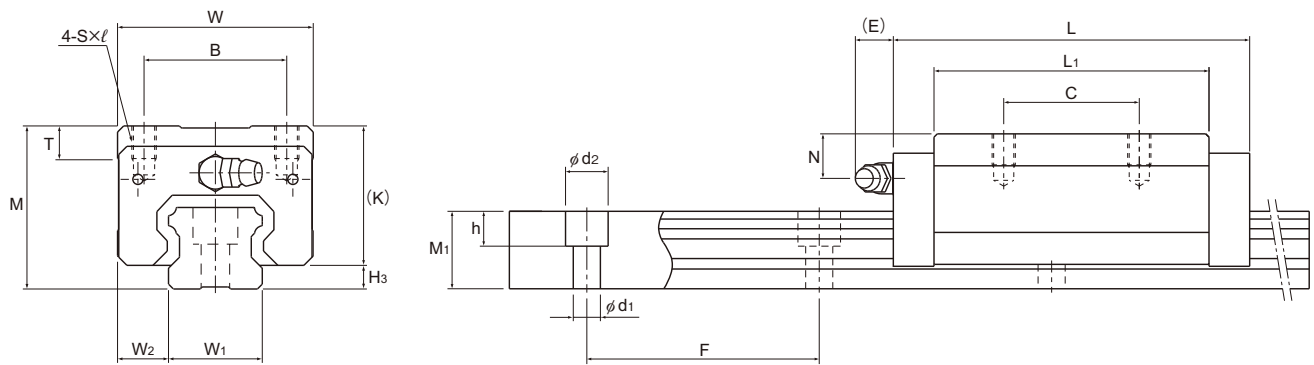

Unit: mm

Model No.	Outer dimensions			LM block dimensions									Grease nipple	H ₃	Basic load rating		Static permissible moment kN-m*					LM block kg
	Height	Width	Length	B	C	S × l	L ₁	T	K	N	E	C			C ₀	M _A		M _B		M _C		
	M	W	L									kN			kN	1 block	Double blocks	1 block	Double blocks	1 block		
SHS 15R	28	34	64.4	26	26	M4×5	48	5.9	25	9.5	5.5	PB1021B	3	14.2	24.2	0.175	0.898	0.175	0.898	0.16	0.22	
SHS 25R	40	48	92	35	35	M6×8	71	8	34.2	11.5	12	B-M6F	5.8	31.7	52.4	0.566	2.75	0.566	2.75	0.563	0.66	
SHS 25LR			109				88							36.8	64.7	0.848	3.98	0.848	3.98	0.696	0.8	
SHS 30R	45	60	106	40	40	M8×10	80	8	38	11	12	B-M6F	7	44.8	66.6	0.786	4.08	0.786	4.08	0.865	1.04	
SHS 30LR			131				105							54.2	88.8	1.36	6.6	1.36	6.6	1.15	1.36	
SHS 35R	55	70	122	50	50	M8×12	93	14.7	47.5	15	12	B-M6F	7.5	62.3	96.6	1.38	6.76	1.38	6.76	1.53	1.8	
SHS 35LR			152				123							72	127	2.34	10.9	2.34	10.9	2.01	2.34	
SHS 45R	70	86	140	60	60	M10×17	106	14.9	61.1	20.5	16	B-R1/8 (B-PT1/8)	8.9	82.8	126	2.05	10.1	2.05	10.1	2.68	3.24	
SHS 45LR			174				140							166	3.46	16.3	3.46	16.3	3.53	4.19		

*1 block: static permissible moment value with 1 LM block

Double blocks: static permissible moment value with 2 blocks closely contacting with each other

SHS LM RAIL

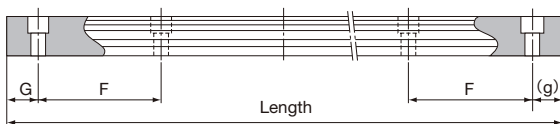

LM rail dimensions (Model SHS)

Unit: mm

Model No.	LM rail dimensions							length (G,g)	LM rail kg/m
	Width	Height	Pitch						
	W ₁ 0 -0.05	W ₂	M ₁	F	d ₁ × d ₂ × h				
SHS 15	15	16	13	60	4.5 × 7.5 × 5.3	3000(20,40)	—	1.3	
SHS 20	20	21.5	16.5	60	6 × 9.5 × 8.5	3000(20,40)	4540(20,20)	2.3	
SHS 25	23	23.5	20	60	7 × 11 × 9	3000(20,40)	4540(20,20)	3.2	
SHS 30	28	31	23	80	9 × 14 × 12	3000(20,20)	4520(20,20)	4.5	
SHS 35	34	33	26	80	9 × 14 × 12	3000(20,20)	4520(20,20)	6.2	
SHS 45	45	37.5	32	105	14 × 20 × 17	3000(20,40)	4560(22.5,22.5)	10.4	

Please contact the LM rail length you need to your dealer

Model number coding

SHS25 C 1 SS C1 H (GK) BLOCK

Model number

Type of LM block

GK series must be "1".

GK series LM block symbol

Accuracy Grade
Normal grade (No Symbol)
High grade (H)

Radial clearance symbol
Normal (No symbol)
Light preload (C1)

Contamination protection accessory symbol
SS : With end seal + side seal + inner seal
GK series must be "SS".

SHS25 - 3000L H (GK) RAIL

Model number

LM rail length (in mm)

GK series LM rail symbol

Accuracy Grade
Normal grade (No Symbol)
High grade (H)

Model SR

Models SR-V

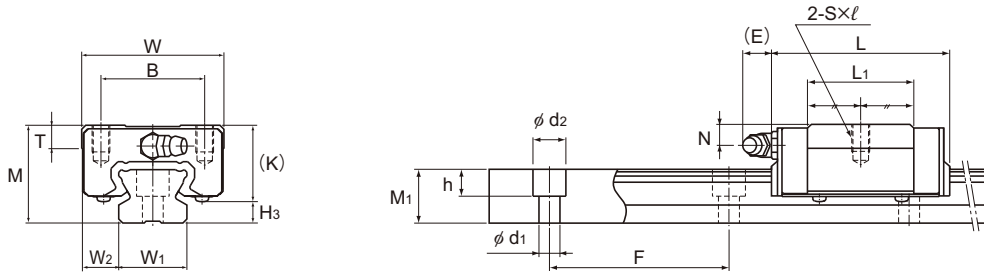

Unit: mm

Model No.	Outer dimensions			LM block dimensions									Grease nipple	H ₃	Basic load rating		Static permissible moment kN-m*					LM block kg
	Height M	Width W	Length L	B	C	S×ℓ	L ₁	T	K	N	E	C			C ₀	M _A		M _B		M _C		
																1 block	Double blocks	1 block	Double blocks	1 block		
SR 15V	24	34	40.4	26	—	M4×7	22.9	5.7	18.2	6	5.5	PB1021B	5.8	9.1	11.7	0.0344	0.234	0.0215	0.149	0.0694	0.12	
SR 20V	28	42	47.3	32	—	M5×8	27.8	7.2	22	6	12	B-M6F	6	13.4	17.2	0.064	0.396	0.0397	0.25	0.135	0.2	
SR 25V	33	48	59.2	35	—	M6×9	35.2	7.7	26	7	12	B-M6F	7	21.6	26.8	0.125	0.773	0.0774	0.488	0.245	0.3	
SR 30V	42	60	67.9	40	—	M8×12	40.4	8.5	32.5	8	12	B-M6F	9.5	29.5	34.4	0.173	1.15	0.108	0.735	0.376	0.5	
SR 35V	48	70	77.6	50	—	M8×12	45.7	12.5	36.5	8.5	12	B-M6F	11.5	40.9	46.7	0.275	1.79	0.171	1.14	0.615	0.8	

*1 block: static permissible moment value with 1 LM block

Double blocks: static permissible moment value with 2 blocks closely contacting with each other

Models SR-W

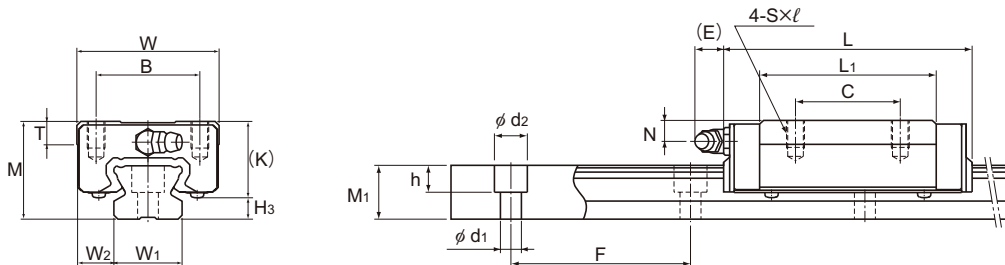

Unit: mm

Model No.	Outer dimensions			LM block dimensions									Grease nipple	H ₃	Basic load rating		Static permissible moment kN-m*					LM block kg
	Height M	Width W	Length L	B	C	S×ℓ	L ₁	T	K	N	E	C			C ₀	M _A		M _B		M _C		
																1 block	Double blocks	1 block	Double blocks	1 block		
SR 15W	24	34	57	26	26	M4×7	39.5	5.7	18.2	6	5.5	PB1021B	5.8	13.8	20.5	0.0984	0.551	0.0604	0.343	0.122	0.2	
SR 20W	28	42	66.2	32	32	M5×8	46.7	7.2	22	6	12	B-M6F	6	19.2	28.6	0.167	0.887	0.102	0.55	0.224	0.3	
SR 25W	33	48	83	35	35	M6×9	59	7.7	26	7	12	B-M6F	7	30.9	44.7	0.326	1.74	0.2	1.08	0.408	0.4	
SR 30W	42	60	96.8	40	40	M8×12	69.3	8.5	32.5	8	12	B-M6F	9.5	45.6	64.4	0.564	2.92	0.346	1.8	0.703	0.8	
SR 35W	48	70	111	50	50	M8×12	79	12.5	36.5	8.5	12	B-M6F	11.5	60.4	81.8	0.785	4.27	0.482	2.65	1.08	1.2	

*1 block: static permissible moment value with 1 LM block

Double blocks: static permissible moment value with 2 blocks closely contacting with each other

Model SR-TB

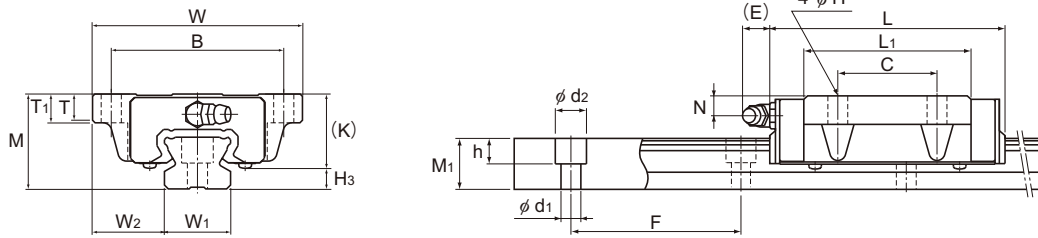

Unit: mm

Model No.	Outer dimensions			LM block dimensions										Grease nipple	H ₃	Basic load rating		Static permissible moment kN-m*					LM block kg
	Height M	Width W	Length L	B	C	H	L ₁	T	T ₁	K	N	E	C			C ₀	M _A		M _B		M _C		
																	1 block	Double blocks	1 block	Double blocks	1 block		
SR 15TB	24	52	57	41	26	4.5	39.5	6.1	7	18.2	6	5.5	PB1021B	5.8	13.8	20.5	0.0984	0.551	0.0604	0.343	0.122	0.2	
SR 20TB	28	59	66.2	49	32	5.5	46.7	8	9	22	6	12	B-M6F	6	19.2	28.6	0.167	0.887	0.102	0.55	0.224	0.4	
SR 25TB	33	73	83	60	35	7	59	9.1	10	26	7	12	B-M6F	7	30.9	44.7	0.326	1.74	0.2	1.08	0.408	0.6	
SR 30TB	42	90	96.8	72	40	9	69.3	8.7	10	32.5	8	12	B-M6F	9.5	45.6	64.4	0.564	2.92	0.346	1.8	0.703	1.1	
SR 35TB	48	100	111	82	50	9	79	11.2	13	36.5	8.5	12	B-M6F	11.5	60.4	81.8	0.785	4.27	0.482	2.65	1.08	1.5	

*1 block: static permissible moment value with 1 LM block

Double blocks: static permissible moment value with 2 blocks closely contacting with each other

SR LM RAIL

LM rail dimensions (Model SR)

Unit: mm

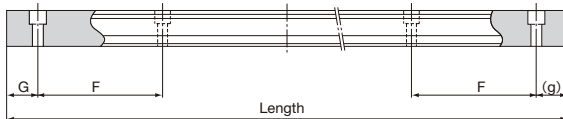

Model No.	LM rail dimensions							Length		Mass LM rail kg/m
	Width W ₁ ±0.05	W ₂	Height M ₁	Pitch F	d ₁ × d ₂ × h		(G,g)			
	SR 15Y	15	9.5	12.5	60	4.5 × 7.5 × 5.3	3000(20,40)	—	1.2	
SR 20	20	11	15.5	60	6 × 9.5 × 8.5	3000(20,40)	4540(20,20)	2.1		
SR 25Y	23	12.5	18	60	7 × 11 × 9	3000(20,40)	4540(20,20)	2.7		
SR 30	28	16	23	80	7 × 11 × 9	3000(20,20)	4520(20,20)	4.3		
SR 35	34	18	27.5	80	9 × 14 × 12	3000(20,20)	4520(20,20)	6.4		

Please contact the LM rail length you need to your dealer

Model number coding

SR25 TB 1 SS C1 H (GK) BLOCK

Model number

Type of LM block

1

SS

C1

H

(GK) BLOCK

GK series must be "1".

Contamination protection accessory symbol
SS: With end seal + side seal
GK series must be "SS".

Radial clearance symbol
Normal (No symbol)
Light preload (C1)

GK series
LM block symbol

Accuracy Grade
Normal grade (No Symbol)
High grade (H)
Precision grade (P)

SR25 - 3000LY H (GK) RAIL

Model number

LM rail length (in mm)

3000

LY

H

(GK) RAIL

Applied to only 15 and 25

GK series
LM rail symbol

Accuracy Grade
Normal grade (No Symbol)
High grade (H)
Precision grade (P)

Model SSR-XV

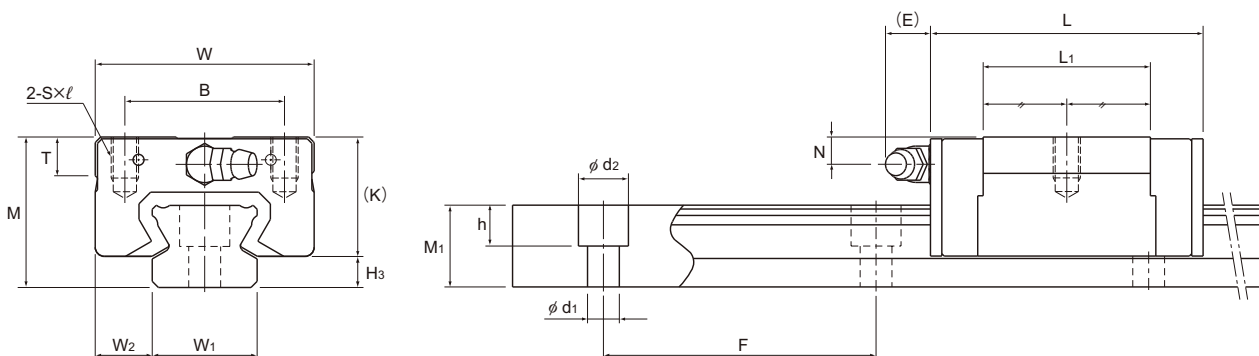

Unit: mm

Model No.	Outer dimensions			LM block dimensions								Grease nipple	Basic load rating			Static permissible moment kN-m*					Mass LM block kg
	Height M	Width W	Length L	B	S × ℓ	L ₁	T	K	N	E	H ₃		C kN	C ₀ kN	M _A		M _B		M _C		
															1 block	Double blocks	1 block	Double blocks	1 block		
SSR 15XV	24	34	40.3	26	M4×7	23.3	6.5	19.5	4.5	5.5	PB1021B	4.5	9.1	9.7	0.0303	0.192	0.0189	0.122	0.0562	0.08	
SSR 20XV	28	42	47.7	32	M5×8	27.8	8.2	22	5.5	12	B-M6F	6	13.4	14.4	0.0523	0.336	0.0326	0.213	0.111	0.14	
SSR 25XV	33	48	60	35	M6×9	36.8	8.4	26.2	6	12	B-M6F	6.8	21.7	22.5	0.104	0.661	0.0652	0.419	0.204	0.23	

*1 block: static permissible moment value with 1 LM block
 Double blocks: static permissible moment value with 2 blocks closely contacting with each other

Model SSR-XW

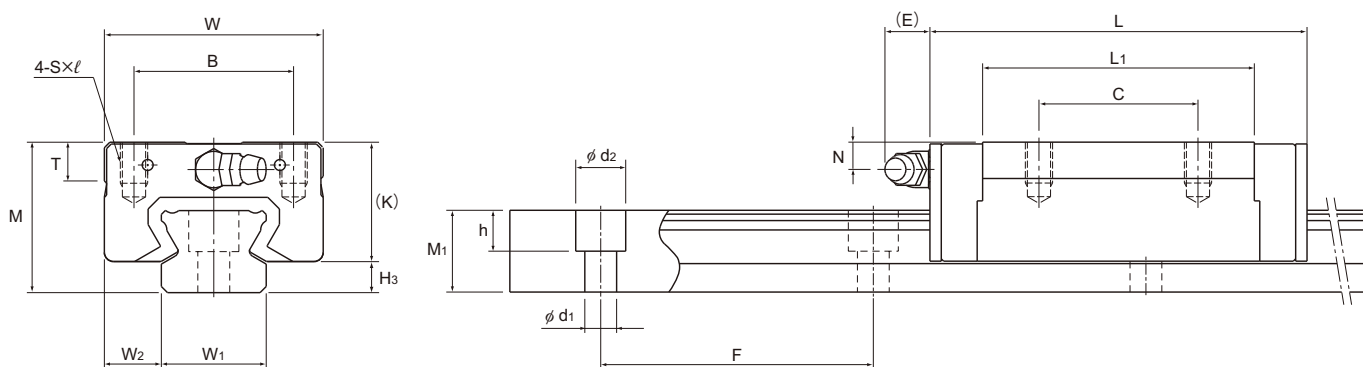

Unit: mm

Model No.	Outer dimensions			LM block dimensions								Grease nipple	Basic load rating			Static permissible moment kN-m*					Mass LM block kg
	Height M	Width W	Length L	B	C	S × ℓ	L ₁	T	K	N	E		H ₃	C kN	C ₀ kN	M _A		M _B		M _C	
																1 block	Double blocks	1 block	Double blocks	1 block	
SSR 15XW	24	34	56.9	26	26	M4×7	39.9	6.5	19.5	4.5	5.5	PB1021B	4.5	14.7	16.5	0.0792	0.44	0.0486	0.274	0.0962	0.15
SSR 20XW	28	42	66.5	32	32	M5×8	46.6	8.2	22	5.5	12	B-M6F	6	19.6	23.4	0.138	0.723	0.0847	0.448	0.18	0.25
SSR 25XW	33	48	83	35	35	M6×9	59.8	8.4	26.2	6	12	B-M6F	6.8	31.5	36.4	0.258	1.42	0.158	0.884	0.33	0.4
SSR 30XW	42	60	97	40	40	M8×12	70.7	11.3	32.5	8	12	B-M6F	9.5	46.5	52.7	0.446	2.4	0.274	1.49	0.571	0.8
SSR 35XW	48	70	110.9	50	50	M8×12	80.5	13	36.5	8.5	12	B-M6F	11.5	64.6	71.6	0.711	3.72	0.437	2.31	0.936	1.1

*1 block: static permissible moment value with 1 LM block
 Double blocks: static permissible moment value with 2 blocks closely contacting with each other

Model SSR-XTB

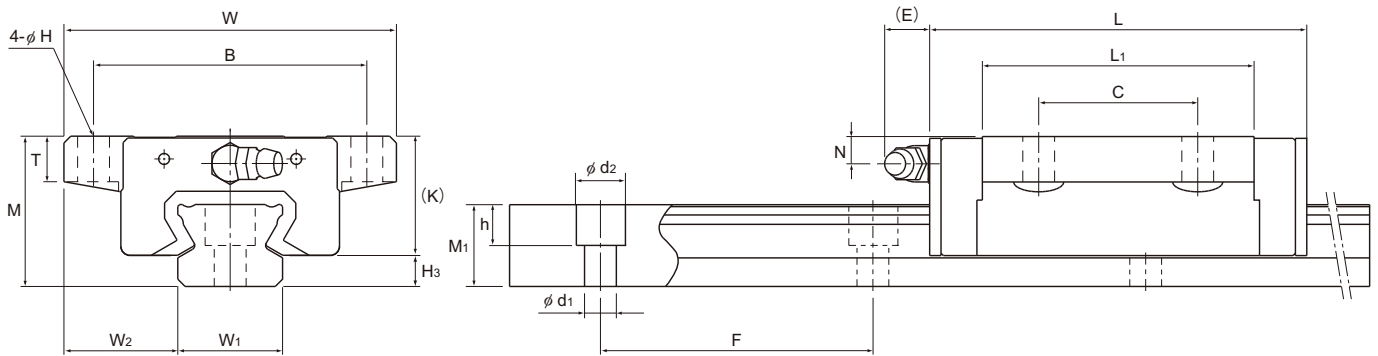

Unit: mm

Model No.	Outer dimensions			LM block dimensions								Grease nipple	Basic load rating			Static permissible moment kN-m*			Mass LM block kg		
	Height	Width	Length	B	C	H	L ₁	T	K	N	E		H ₃	C	C ₀	M _A		M _B		M _C	
	M	W	L													1 block	Double blocks	1 block		Double blocks	1 block
SSR 15XTB	24	52	56.9	41	26	4.5	39.9	7	19.5	4.5	5.5	PB1021B	4.5	14.7	16.5	0.0792	0.44	0.0486	0.274	0.0962	0.19
SSR 20XTB	28	59	66.5	49	32	5.5	46.6	9	22	5.5	12	B-M6F	6	19.6	23.4	0.138	0.723	0.0847	0.448	0.18	0.31
SSR 25XTB	33	73	83	60	35	7	59.8	10	26.2	6	12	B-M6F	6.8	31.5	36.4	0.258	1.42	0.158	0.884	0.33	0.53

*1 block: static permissible moment value with 1 LM block

Double blocks: static permissible moment value with 2 blocks closely contacting with each other

SSR LM RAIL

SR and SSR share a common rail.

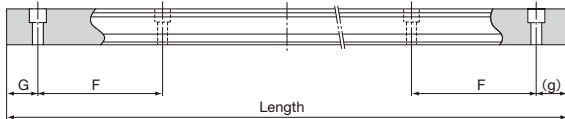

LM rail dimensions (Model SSR)

Unit: mm

Model No.	LM rail dimensions							Mass LM rail kg/m
	Width W ₁ ±0.05	W ₂	Height M ₁	Pitch F	Pitch d ₁ × d ₂ × h		Length (G,g)	
SR 15Y	15	9.5	12.5	60	4.5 × 7.5 × 5.3		3000(20,40)	1.2
SR 20	20	11	15.5	60	6 × 9.5 × 8.5		3000(20,40) 4540(20,20)	2.1
SR 25Y	23	12.5	18	60	7 × 11 × 9		3000(20,40) 4540(20,20)	2.7
SR 30	28	16	23	80	7 × 11 × 9		3000(20,20) 4520(20,20)	4.3
SR 35	34	18	27.5	80	9 × 14 × 12		3000(20,20) 4520(20,20)	6.4

Please contact the LM rail length you need to your dealer

Model number coding

SSR25 XW 1 SS C1 H (GK) BLOCK

Model number
Type of LM block

GK series
LM block symbol

Accuracy Grade
Normal grade (No Symbol)
High grade (H)

Radial clearance symbol
Normal (No symbol)
Light preload (C1)

Contamination protection accessory symbol
SS : With end seal + side seal
GK series must be "SS".

GK series must be "1".

SR25 - 3000LY H (GK) RAIL

Model number
LM rail length (in mm)
Applied to only 15 and 25

GK series
LM rail symbol

Accuracy Grade
Normal grade (No Symbol)
High grade (H)

Model SRS-G

Model SRS-GM and SRS-GN

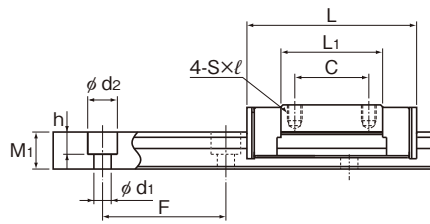
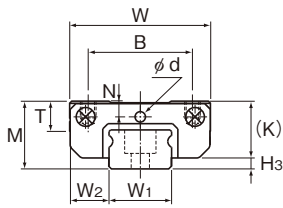

SRS9XGM/9XGN/12GM/12GN

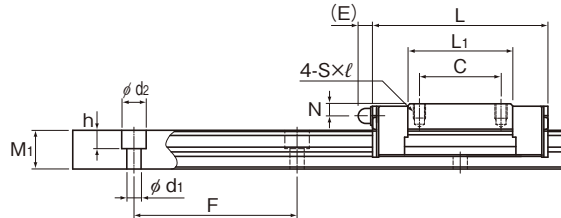
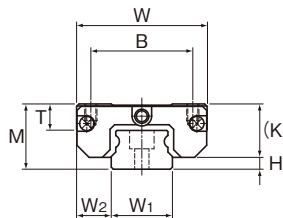

SRS15GM/15GN

Unit: mm

Model No.	Outer dimensions			LM block dimensions										Basic load rating		Static permissible moment kN-m*					Mass LM block g	
	Height M	Width W	Length L	B	C	S x l	L ₁	T	K	N	E	Greasing hole d	Grease nipple	H ₃	C kN	C ₀ kN	M _A		M _B			M _C
																	1 block	Double blocks	1 block	Double blocks		1 block
SRS 9XGM SRS 9XGN	10	20	30.8 40.8	15	10 16	M3x2.8	19.8 29.8	4.5	8.5	2.4	—	1.6	—	1.5	2.22 2.94	3.06 4.59	9.87 21.1	57.9 111	11.4 24.4	66.9 128	14.1 21.1	16 24
SRS 12GM SRS 12GN	13	27	34.4 47.1	20	15 20	M3x3.2	20.6 33.3	5.7	11	3	—	2	—	2	3.36 4.72	3.55 6.83	12.1 34.8	79.0 195	12.1 34.8	79.0 195	23.2 44.7	27 49
SRS 15GM SRS 15GN	16	32	43 60.8	25	20 25	M3x3.5	25.7 43.5	6.5	13.3	3	4	—	PB107	2.7	5.59 8.27	5.72 11.9	24.8 82.3	158 433	24.8 82.3	158 433	40.6 84.5	47 95

*1 block: static permissible moment value with 1 LM block
Double blocks: static permissible moment value with 2 blocks closely contacting with each other

SRS-G LM RAIL

SRS-G and SRS share a common rail.

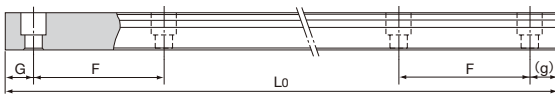

LM rail dimensions (Model SRS)

Unit: mm

Model No.	LM rail dimensions							Mass LM rail g/m
	Width W ₁ 0 -0.02	W ₂	Height M ₁	Pitch F	d ₁ x d ₂ x h	Length (G,g)		
SRS 9	9	5.5	5.5	20	3.5x6x3.3	1000(7.5,12.5)	1200(7.5,12.5)	360
SRS 12	12	7.5	7.5	25	3.5x6x4.5	1000(10,15)	2000(10,15)	650
SRS 15	15	8.5	9.5	40	3.5x6x4.5	1000(15,25)	2000(10,15)	960

Please contact the LM rail length you need to your dealer

Unit: mm

Model No.	LM rail dimensions							Mass LM rail g/m	
	Width W ₁ 0 -0.02	W ₂	W ₃	Height M ₁	Pitch F	d ₁ x d ₂ x h	Length (G,g)		
SRS 9W	18	6	—	7.5	30	3.5x6x4.5	1000(10,30)	1200(10,20)	1010
SRS 12W	24	8	—	8.5	40	4.5x8x4.5	1000(15,25)	2000(15,25)	1520
SRS 15W	42	9	23	9.5	40	4.5x8x4.5	1000(15,25)	2000(15,25)	2870

Please contact the LM rail length you need to your dealer

Model SRS-WGM and SRS-WGN

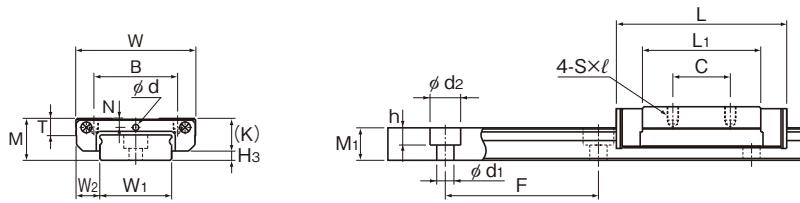

SRS9WGM/9WGN/12WGM/12WGN

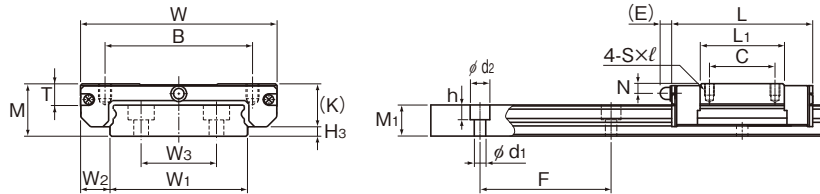

SRS15WGM/15WGN

Unit: mm

Model No.	Outer dimensions			LM block dimensions										Basic load rating		Static permissible moment kN-m*						Mass LM block g	
	Height M	Width W	Length L	B	C	S×ℓ	L ₁	T	K	N	E	Greasing hole d	Grease nipple	H ₃	C kN	C ₀ kN	M _A		M _B		M _C		
																	1 block	Double blocks	1 block	Double blocks	1 block		Double blocks
SRS 9WGM	12	30	39	21	12	M3×2.8	27	4.9	9.1	2.3	—	1.6	—	2.9	2.67	3.35	13.9	69.7	16.6	96.7	31.7	31	
SRS 9WGN			50.7	23	24	M3×2.8	38.7	4.9	9.1	2.3	—	1.6	—	2.9	3.48	5.81	33.2	172	40	208	54.9	49	
SRS 12WGM	14	40	44.5	28	15	M3×3.5	30.9	5.7	11	3	—	2	—	3	4.46	5.32	25.7	146	25.7	146	66.8	55	
SRS 12WGN			59.5	28	28	M3×3.5	45.9	5.7	11	3	—	2	—	3	5.93	9.46	64.7	332	64.7	332	119	91	
SRS 15WGM	16	60	55.5	45	20	M4×4.5	38.9	6.5	13.3	3	4	—	PB107	2.7	7.43	8.59	52.7	293	52.7	293	178	130	
SRS 15WGN			74.5	45	35	M4×4.5	57.9	6.5	13.3	3	4	—	PB107	2.7	9.87	15.3	133	671	133	671	317	201	

*1 block: static permissible moment value with 1 LM block
 Double blocks: static permissible moment value with 2 blocks closely contacting with each other

Model number coding

SRS9X WGN UU C1 H (GK) BLOCK

Model number

Type of LM block

UU

C1

H

(GK)

BLOCK

SRS9X - 1000L H (GK) RAIL

Model number

LM rail length (in mm)

H

(GK)

RAIL

Accuracy Grade
 Normal grade (No symbol)
 High grade (H)
 Precision grade (P)

Radial clearance symbol
 Normal (No symbol)
 Light preload (C1)

Accuracy Grade
 Normal grade (No symbol)
 High grade (H)
 Precision grade (P)

Contamination protection accessory symbol
 UU : With end seal
 GK series must be "UU".

Model SRS-M and SRS-N

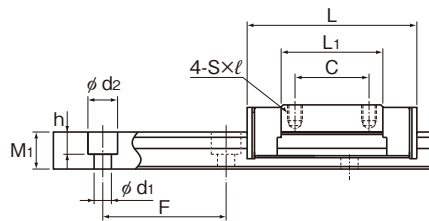
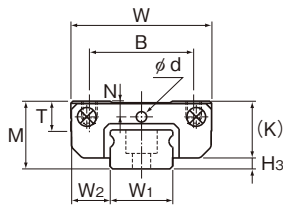

SRS9XM/9XN/12M/12N

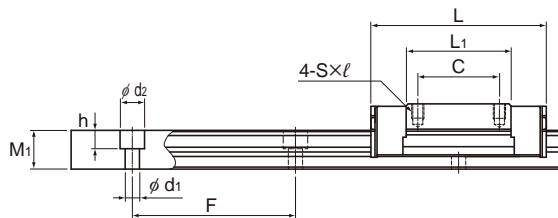
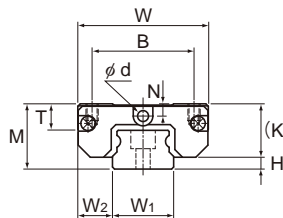

SRS15M/15N

Unit: mm

Model No.	Outer dimensions			LM block dimensions								Greasing hole	H ₃	Basic load rating		Static permissible moment kN-m*						Mass LM block g
	Height M	Width W	Length L	B	C	S × l	L ₁	T	K	N	d			C	C ₀	M _A		M _B		M _C		
																1 block	Double blocks	1 block	Double blocks	1 block	Double blocks	
SRS 9XM SRS 9XN	10	20	30.8 40.8	15	10 16	M3×2.8	19.8 29.8	4.5	8.5	2.4	1.6	1.5	2.69 3.48	2.75 3.98	9.31 18.7	52.2 96.5	10.7 21.6	60.3 112	12.7 18.3	16 24		
SRS 12M SRS 12N	13	27	34.4 47.1	20	15 20	M3×3.2	20.6 33.3	5.7	11	3	2	2	4.00 5.82	3.53 5.30	12.0 28.4	78.5 151	12.0 28.4	78.5 151	23.1 34.7	27 49		
SRS 15M SRS 15N	16	32	43 60.8	25	20 25	M3×3.5	25.7 43.5	6.5	13.3	3	3	2.7	6.66 9.71	5.7 8.55	26.2 59.7	154 312	26.2 59.7	154 312	40.4 60.7	47 95		

*1 block: static permissible moment value with 1 LM block
Double blocks: static permissible moment value with 2 blocks closely contacting with each other

SRS LM RAIL

SRS-G and SRS share a common rail.

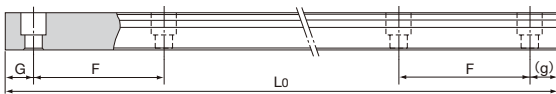

LM rail dimensions (Model SRS)

Unit: mm

Model No.	LM rail dimensions							Mass LM rail g/m
	Width W ₁ 0 -0.02	W ₂	Height M ₁	Pitch F	d ₁ × d ₂ × h	Length (G,g)		
SRS 9	9	5.5	5.5	20	3.5×6×3.3	1000(7.5,12.5)	1200(7.5,12.5)	360
SRS 12	12	7.5	7.5	25	3.5×6×4.5	1000(10,15)	2000(10,15)	650
SRS 15	15	8.5	9.5	40	3.5×6×4.5	1000(15,25)	2000(10,15)	960

Please contact the LM rail length you need to your dealer

Unit: mm

Model No.	LM rail dimensions							Mass LM rail g/m	
	Width W ₁ 0 -0.02	W ₂	W ₃	Height M ₁	Pitch F	d ₁ × d ₂ × h	Length (G,g)		
SRS 9W	18	6	—	7.5	30	3.5×6×4.5	1000(10,30)	1200(10,20)	1010
SRS 12W	24	8	—	8.5	40	4.5×8×4.5	1000(15,25)	2000(15,25)	1520
SRS 15W	42	9	23	9.5	40	4.5×8×4.5	1000(15,25)	2000(15,25)	2870

Please contact the LM rail length you need to your dealer

Model SRS-WM and SRS-WN

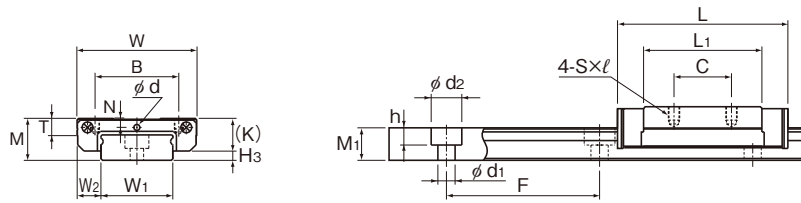

SRS9WM/9WN/12WM/12WN

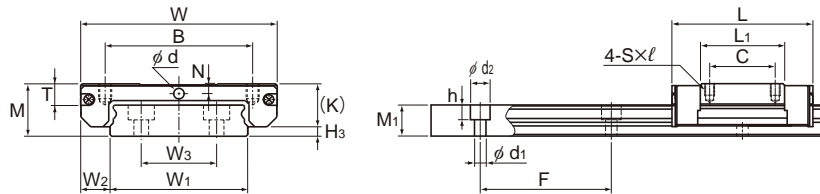

SRS15WM/15WN

Unit: mm

Model No.	Outer dimensions			LM block dimensions								Greasing hole d	H ₃	Basic load rating		Static permissible moment kN-m*						Mass g
	Height M	Width W	Length L	B	C	S×ℓ	L ₁	T	K	N	C			C ₀	M _A		M _B		M _C			
															1 block	Double blocks	1 block	Double blocks	1 block	Double blocks		
SRS 9WM SRS 9WN	12	30	39 50.7	21 23	12 24	M3×2.8	27 38.7	4.9	9.1	2.3	1.6	2.9	3.29 4.20	3.34 4.37	14.0 25.1	78.6 130	16.2 29.1	91.0 151	31.5 41.3	31 49		
SRS 12WM SRS 12WN	14	40	44.5 59.5	28	15 28	M3×3.5	30.9 45.9	5.7	11	3	2	3	5.48 7.13	5.3 7.07	26.4 49.2	143 249	26.4 49.2	143 249	66.5 88.7	55 91		
SRS 15WM SRS 15WN	16	60	55.5 74.5	45	20 35	M4×4.5	38.9 57.9	6.5	13.3	3	3	2.7	9.12 12.4	8.55 12.1	51.2 106	290 532	51.2 106	290 532	176 250	130 201		

*1 block: static permissible moment value with 1 LM block
Double blocks: static permissible moment value with 2 blocks closely contacting with each other

Model number coding

SRS9X WN UU C1 H (GK) BLOCK

Model number
Type of LM block

GK series
LM block symbol

Accuracy Grade
Normal grade (No symbol)
High grade (H)
Precision grade (P)

Radial clearance symbol
Normal (No symbol)
Light preload (C1)

Contamination protection accessory symbol
UU : With end seal
GK series must be "UU".

SRS9X - 1000L H (GK) RAIL

Model number
LM rail length (in mm)

GK series
LM rail symbol

Accuracy Grade
Normal grade (No symbol)
High grade (H)
Precision grade (P)

Lubrication

When using the LM Guide, be sure to lubricate it well.

If traveling is carried out without lubrication or the lubrication runs out during traveling, the wear of the balls and ball rolling elements, which shortens the service life.

The lubricant has the following roles:

- (1) Minimizes friction in the traveling unit to prevent seizure and reduce wear.
- (2) Forms an oil film on the raceway to decrease stress acting on the surface and extend rolling life.
- (3) Covers the metal surface to prevent rust formation.

To fully bring out the LM Guide's functions, it is necessary to provide lubrication according to the conditions.

LM Guide GK Series has lithium soap-based grease (AFB-LF grease) contained as standard.(SRS-G/SRS : Only antirust oil)

●Precautions

- Do not use a mix of lubricants with different physical properties. Mixing lubricants using the same type of thickening agent may still cause mutually adverse impacts on the two lubricants if they use different additives, etc.
- The properties of lubricant deteriorate and its lubrication performance drops over time. Lubricants must be checked and added properly according to the use frequency of the machine.
- The appropriate lubrication schedule will depend on usage conditions and the surrounding environment. In general, the unit should be lubricated after every 100 kilometers of operation (every 3 to 6 months) in the case of the full-component LM Guide. Set the final lubrication interval/ amount based on the actual machine.
- If the mounting orientation of the LM Guide is other than horizontal use (i.e., vertical, wall and inverted mount), the lubricant may not reach the raceway completely. Be careful.

Lubrication Methods Manual Greasing

Generally, grease is replenished periodically, fed through a grease nipple provided on the LM block, using a grease gun.

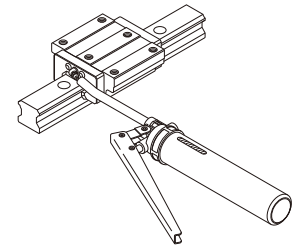

Fig.4 Lubrication Using a Grease Gun

Lubrication Equipment

Grease Gun Unit MG70

Grease Gun Unit MG70 is capable of lubricating small to large models by replacing dedicated nozzles (attached). For small models, dedicated attachments are provided. The user can select from these attachments according to the model number and the installation space.

Grease Gun has a slit window, allowing the user to check the remaining amount of grease.

Since a 70g type of THK original grease is contained in a bellows cartridge, you can install it on the grease gun unit and replace it without soiling your hand.

Grease Nipple Model No.	Type	Dimensional Drawing
PB1021B	Type N	
B-M6F	Type H	
B-R1/8 (B-PT1/8)		

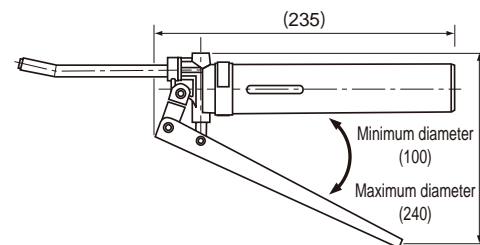

THK Original Grease AFB-LF Grease



- Base Oil: Refined Mineral Oil
- Consistency Enhancer: Lithium-based

AFB-LF Grease is a general-purpose grease developed with a lithium-based consistency enhancer using refined mineral oil as the base oil. It excels in extreme pressure resistance and mechanical stability.

●Features

- (1) High Extreme Pressure Resistance**
Compared with lithium-based greases available on the market, AFB-LF Grease has higher wear resistance and outstanding resistance to extreme pressure due to the action of a special additive.
- (2) High Mechanical Stability**
AFA Grease is not easily softened and demonstrates excellent mechanical stability even when used for a long period of time.
- (3) High Water Resistance**
Compared with ordinary lithium grease, this product is a highly water resistant grease with minimal softening due to moisture penetration and very little deterioration under extreme pressures.
- (4) Long Service Life**
It provides many times the lubrication life of lithium soap-based greases. As a result, it offers a lower maintenance workload and greater economy due to the longer intervals between greasing.

●Representative Physical Properties

Item	Representative Physical Property Value	Test Method
Consistency enhancer	Lithium-based	
Base oil	Refined mineral oil	
Base oil kinematic viscosity: mm ² /s (40°C)	170	ISO 2137 ISO 2176 ISO 6743 ISO 11009 ISO 12924
Worked penetration (25°C, 60W)	275	
Mixing stability (100,000 W)	345	
Dropping point °C	193	
Evaporation amount: mass% (99°C, 22 h)	0.4	
Oil separation rate: mass% (100°C, 24 h)	0.6	
Copper plate corrosion (B method, 100°C, 24 h)	Accepted	
Low temperature torque: mN·m (-20°C)	When starting up	130
	When revolving	51
4-ball test (fusion load): N	3089	ASTM D2596
Temperature range °C	-15 to 100	
Appearance color	Brownish yellow	

●Comparison Data of Service Life in Travel Distance in Relation to Grease

<Test Product>

LM Guide HSR25CA1SS + 600L

<Test Conditions>

Item	Description
Load	9.8 kN/block
Stroke	350mm
Speed	30m/min(MAX)
Acceleration	2.5m/s ²
Lubrication amount	4cm ³ /block (initial lubrication only)

Travel distance until flaking takes place

Grease	Distance						(km)
	0	100	200	300	400	500	
AFB-LF Grease							
General lithium soap group grease							

Grease Nipple

THK provides various types of grease nipples needed for the lubrication of LM systems.

Model PB1021B

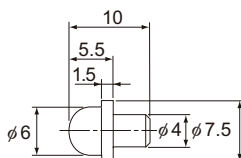

Model B-M6F (M6×0.75)

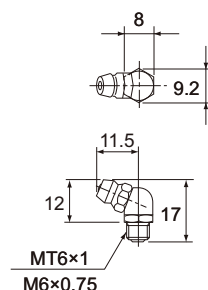

Model B-R1/8 (Model B-PT1/8)

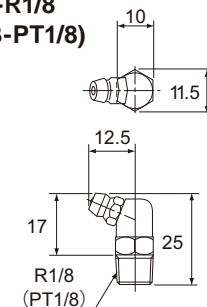

Note) LM Guide GK Series has a grease nipple. (Not attached to the LM block)

Attach a grease nipple when mounting the LM Guide. Attach a bundled plug to the opposite side of the LM block.

Contamination Protection Accessories to Attach to LM Blocks

If any foreign materials enter the LM Guide, abnormal wear and ball clogging becomes easier to occur, which shortens the service life. Therefore, it should be protected from contamination by the foreign materials entered.

LM Guide GK Series have an end seal and side seal (Contamination protection accessory symbol : SS (SRS : "UU")) as standard.

•End Seal

This is a general seal to attach to both ends of a LM block. Attach this in normal environments (atmosphere and room temperature) and contaminated environments (dust and cutting chips). One of its purposes is to remove dust from the upper face and side face of the LM rail. In addition to contamination protection, it is also a purpose to retain the lubricant in the LM block.

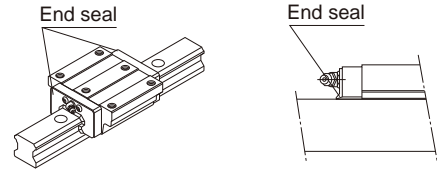

•Side Seal

This is a general seal to attach to the lower part of a LM block. Attach this in normal environments (atmosphere and room temperature) and contaminated environments (dust and cutting chips). Its purpose is to prevent entrance of dust from the bottom of the LM block. This contamination protection accessory is especially useful for environments where the mounting orientation is inverted mount or dust flutters.

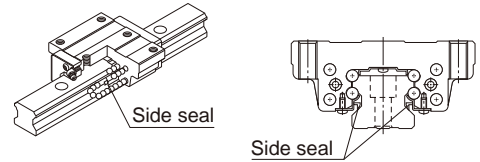

Contamination Protection Accessories to Attach to LM Rail

•Dedicates Cap C (C Cap)

This is a special resin cap to block the mounting holes of the LM rail. Preventing any influx of cutting chips, foreign material, or coolant into the LM blocks from the top face of the LM rail, coupled with the use of seals, will improve the contamination protection performance for the LM guide.

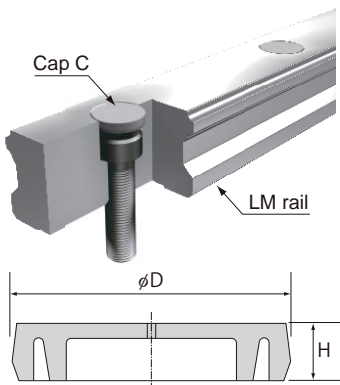

Model No.	LM rail	Main dimensions (mm)		LM Guide model number					
	mounting bolt	Outer diameter D	Thickness H	HSR	SHS	SR	SSR	SRS-G	SRS
C3	M3	6.3	1.2	-	-	-	-	9W,12,15	-
C4	M4	7.8	1	15	-	15	-	-	-
C5	M5	9.8	2.4	20	-	20	-	-	-
C6	M6	11.4	2.7	25	-	25,30	-	-	-
C8	M8	14.4	3.7	30,35	-	35	-	-	-
C12	M12	20.5	4.7	45	-	-	-	-	-

•Mounting method

The procedure for inserting a C cap into a mounting hole consists of using a flat aligning fitting to gradually punch the cap into the hole until it is level with the upper surface of the LM rail, as shown in the figure. Fit C caps without removing the LM rail from the LM block.

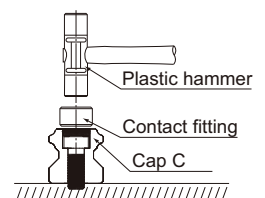

Mounting the LM Guide

Markings on the Reference Surface

LM Guide has a reference surface.

The accuracy grade of the LM Guide is specified based on the reference surface.

The reference surface of the LM block is opposite to the surface marked with the THK logo and the model No. while the reference surface of the LM rail is on the bottom of the LM rail marked with a line.

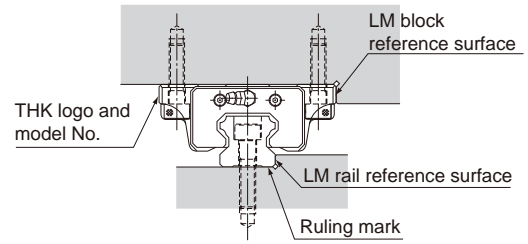

Fig.5 Reference surface of the LM Guide

Combined Use of an LM Rail and LM Blocks

Combine so that the reference surface of the LM rail and LM blocks should face the same direction.

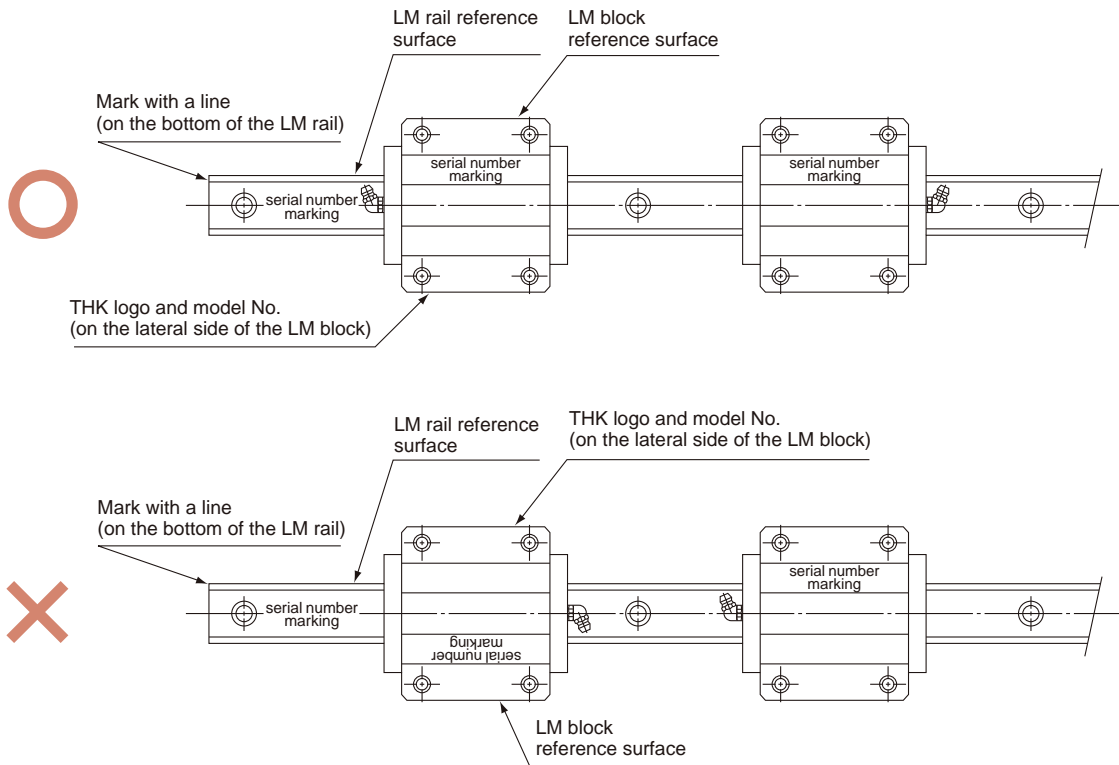

Fig.6 Combined Use of an LM Rail and LM Blocks

Note) LM Guide GK Series has a grease nipple. (Not attached to the LM block)

Attach a grease nipple when mounting the LM Guide. Attach a bundled plug to the opposite side of the LM block.

Installing the LM Blocks

Use the bundled removing/mounting jig when mounting the LM blocks to the LM rail in its assembly, etc.

When the LM blocks are inserted into the LM rail without using the removing/mounting jig, balls may drop out from an LM block due to entered foreign materials, damaged internal components, or slight tilt. Using the LM Guide with some of the balls missing may cause damage at an early stage.

Align the removing/mounting jig to the end face of the LM rail without tilting or separating when used. (See Fig.7)

The removing/mounting jig is not provided as standard. To use the jig, contact THK.

Also contact THK when balls drop out during mounting.

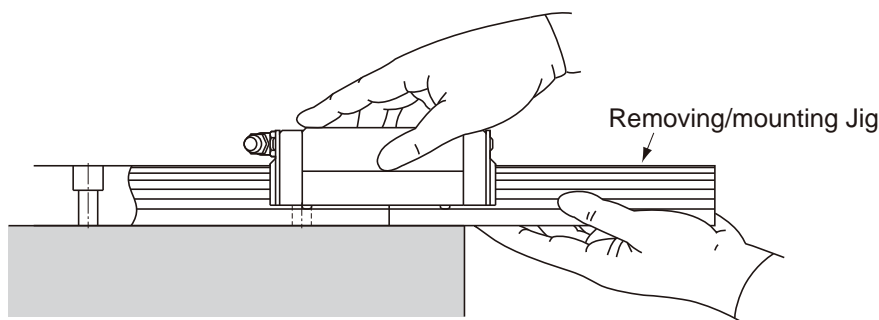

Fig.7 Installing the LM Blocks

Shoulder Height of the Mounting Base and the Corner Radius

The mounting surface and reference surface of the LM rail and LM block are ground to support highly accurate positioning.

To assemble the LM Guide correctly, there are guideline dimensions for the "height of the datum shoulder" and "corner radius r " of the table and base for each LM Guide type and size.

Model HSR

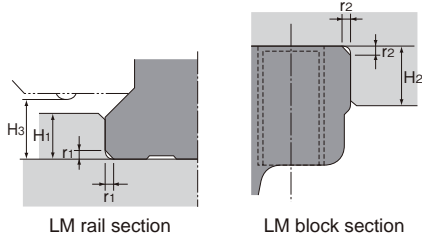

LM rail section

LM block section

Unit: mm

Model No.	Corner radius for the LM rail $r_1(\text{max})$	Shoulder height for the LM rail H_1	Shoulder height for the LM block H_2	H_3
15	0.5	3	4	4.7
20	0.5	3.5	5	4
25	1	5	5	5.5
30	1	5	5	7
35	1	6	6	7.5
45	1	8	8	10

Model SR

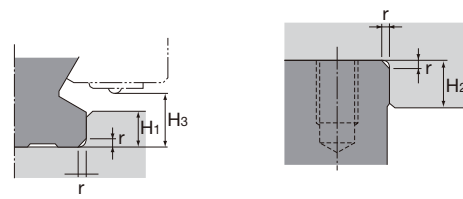

LM rail section

LM block section

Unit: mm

Model No.	Corner radius $r(\text{max})$	Shoulder height for the LM rail H_1	Maximum shoulder height for the LM block H_2	H_3
15	0.5	3.8	4	5.8
20	0.5	5	5	6
25	1	5.5	5	7
30	1	8	6	9.5
35	1	9	6	11.5

Model SHS

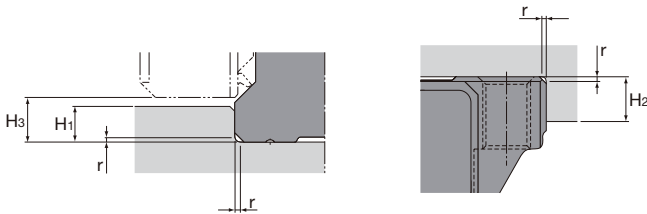

LM rail section

LM block section

Unit: mm

Model No.	Corner radius $r(\text{max})$	Shoulder height for the LM rail H_1	Shoulder height for the LM block H_2	H_3
15	0.5	2.5	4	3
20	0.5	3.5	5	4.6
25	1	5	5	5.8
30	1	5	5	7
35	1	6	6	7.5
45	1	7.5	8	8.9

Model SSR

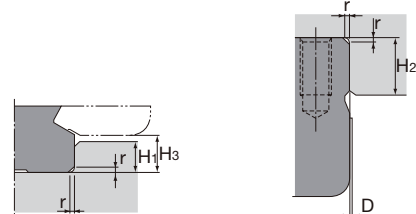

LM rail section

LM block section

Unit: mm

Model No.	Corner radius $r(\text{max})$	Shoulder height for the LM rail H_1	Maximum shoulder height for the LM block H_2	H_3	D
15 X	0.5	3.8	5.5	4.5	0.3
20 X	0.5	5	7.5	6	0.3
25 X	1	5.5	8	6.8	0.4
30 X	1	8	11.5	9.5	0.4
35 X	1	9	16	11.5	0.4

Model SRS-G/SRS

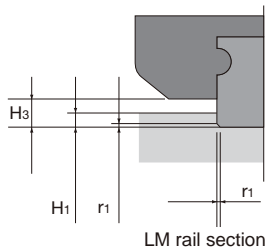

LM rail section

Unit: mm

Model No.	Corner radius for the LM rail $r_1(\text{max})$	Corner radius for the LM block $r_2(\text{max})$	Shoulder height for the LM rail H_1	Shoulder height for the LM block H_2	H_3
SRS 9XGM/9XM SRS 9XGN/9XN	0.1	0.3	1.1	4.5	1.5
SRS 12GM/12M SRS 12GN/12N	0.3	0.2	1.5	5.7	2
SRS 15GM/15M SRS 15GN/15N	0.3	0.4	2.2	6.5	2.7

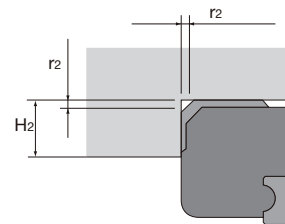

LM block section

Unit: mm

Model No.	Corner radius for the LM rail $r_1(\text{max})$	Corner radius for the LM block $r_2(\text{max})$	Shoulder height for the LM rail H_1	Shoulder height for the LM block H_2	H_3
SRS 9WGM/9WM SRS 9WGN/9WN	0.1	0.5	2.5	4.9	2.9
SRS 12WGM/12WM SRS 12WGN/12WN	0.3	0.3	2.5	5.7	3
SRS 15WGM/15WM SRS 15WGN/15WN	0.3	0.3	2.2	6.5	2.7

Precautions on Using the LM Guide

[Handling]

- (1) Please use at least two people to move any product weighing 20 kg or more, or use a dolly or another conveyance. Otherwise, it may cause injury or damage the unit.
- (2) Do not disassemble the parts. Otherwise, it may reduce functionality.
- (3) Tilting an LM block or LM rail may cause them to fall by their own weight.
- (4) Take care not to drop or strike the LM Guide. Otherwise, it may cause injury or damage the unit. If the product is dropped or impacted, functionality may be reduced even if there is no surface damage.
- (5) Do not remove the LM block from the LM rail during setup.
- (6) Do not insert fingers into the mounting holes on the LM rail, as they could get caught between the rail and the LM block, resulting in injury.
- (7) To ensure personal safety, wear gloves and protective footwear when handling this product.

[Precautions on Use]

- (1) Prevent foreign material, such as cutting chips or coolant, from entering the product. This may also cause damage to the product.
- (2) If the product is used in an environment where cutting chips, coolant, corrosive solvents, water, etc., may enter the product, use bellows, covers, etc., to prevent them from entering the product.
- (3) Do not use the product at temperature of 80°C or higher. Unless the unit is specially designed to be heat-resistant, exposure to such temperatures may deform or damage plastic and rubber parts.
- (4) If foreign material such as cutting chips adheres to the product, replenish the lubricant after cleaning the product.
- (5) Micro-strokes can inhibit the formation of a film of oil between the raceways and the ball, resulting in fretting. So use grease with high fretting resistance. THK recommends periodically making stroke movement of about the length of the LM block to help ensure that a film forms on the raceways and balls.
- (6) Do not forcibly drive a pin, key, or other positioning device into this product. This may generate permanent deformation on the raceway, leading to loss of functionality.
- (7) If, for operational reasons, it becomes absolutely necessary to remove the LM block from the LM rail and reattach it, a special mounting jig must be used for this purpose. (The removing/mounting jig is not provided as standard. When desiring to use it, contact THK.)
- (8) Position the mounting jig so that one end abuts the end of the LM rail. When the rail and the jig are exactly aligned, the LM block can be loaded onto the rail.
- (9) Take care to keep the LM block straight. Loading the block at an angle can introduce foreign material, damage internal components, or cause balls to fall out.
- (10) The LM block must contain all its internal rolling elements (balls) when mounted on the LM rail. Using a block with any balls removed may result in premature damage.
- (11) If any of the balls falls from the LM block, contact THK instead of using the product.
- (12) If the endplate is damaged due to an accident, etc., balls may fall out or the LM block may become detached from the LM rail and drop. If the LM Guide will be used hanging upside down, take preventive measures such as adding a safety mechanism to prevent falls.
- (13) If the durability of the mounting parts are insufficient and the mounting accuracy is bad, an unexpected load will be applied to the LM block, which may cause damage at an early stage. Accordingly, give sufficient consideration to the rigidity/accuracy of the housing and the base.
- (14) When removing the LM block from the LM rail and then replacing the block, an LM block mounting/removing jig that facilitates such installation is available. Contact THK for details.

[Lubrication]

- (1) Thoroughly wipe off anti-rust oil and feed lubricant before using the product.
- (2) Do not use a mix of lubricants with different physical properties. Mixing greases using the same type of thickening agent may still cause adverse interaction between the two greases if they use different additives, etc.
- (3) When using the product in locations exposed to constant vibrations or in special environments such as clean rooms, vacuum and low/high temperature, use the grease appropriate for the specification/environment.
- (4) To lubricate a product that has no grease nipple or oil hole, apply lubricant directly to the raceway surface and execute a few preliminary strokes to ensure that the interior is fully lubricated.
- (5) Lubricant viscosity can vary depending on the temperature. Take note that the slide resistance and torque of the LM Guide also changes as the consistency of grease changes.
- (6) After lubrication, the slide resistance and torque of the LM Guide may increase due to the agitation resistance of grease. Be sure to perform a break-in to let the grease spread fully, before operating the machine.
- (7) Excess lubricant may spatter immediately after lubrication. If necessary, wipe off any spattered grease.
- (8) The properties of grease deteriorate and its lubrication performance drops over time. Grease must be checked and added properly according to the use frequency of the machine.
- (9) Although the lubrication interval may vary according to use conditions and the service environment, lubrication should be performed approximately every 100 km in travel distance (three to six months). Set the final lubrication interval/amount based on the actual machine.
- (10) If the installation direction is other than horizontal use, the lubricant may not reach the raceway completely.
- (11) When adopting oil lubrication, the lubricant may not be distributed throughout the LM block depending on the installation direction of the block. Contact THK in advance for details.

[Storage]

When storing the LM Guide, enclose it in a package designated by THK and store it in a room in a horizontal orientation while avoiding high temperature, low temperature and high humidity.

After the product has been in storage for an extended period of time, lubricant inside may have deteriorated, so add new lubricant before use.

[Disposal]

Dispose of the product properly as industrial waste.

LIMITED WARRANTY

LIMITED WARRANTY AND LIMITATION OF LIABILITY: THK CO. LTD., FOR ITSELF AND ITS RELATED COMPANIES AND SUBSIDIARIES (HEREINAFTER DESCRIBED COLLECTIVELY AS “THK”) WARRANTS THAT ALL THK PRODUCTS SOLD WILL BE FREE OF DEFECTS IN MATERIALS AND WORKMANSHIP FOR A PERIOD OF TWELVE (12) MONTHS FROM DATE OF DELIVERY. THE FOREGOING TWELVE (12) MONTH WARRANTY SHALL NOT BE EXTENDED OR CHANGED BY THK FURNISHING ANY REPLACEMENTS, ADDITIONS, ATTACHMENTS, ACCESSORIES OR REPAIRS TO THE PRODUCT SUBSEQUENT TO THE DATE OF DELIVERY OR ACCEPTANCE. THE FOREGOING WARRANTY IS THE SOLE AND EXCLUSIVE WARRANTY OF THK REGARDING THE PRODUCT.

DISCLAIMER OF OTHER WARRANTIES: OTHER THAN THE FOREGOING WARRANTY, THERE ARE NO EXPRESS OR IMPLIED WARRANTIES OR ANY AFFIRMATIONS OF FACT OR PROMISES BY THK WITH RESPECT TO THE PRODUCT. THK DISCLAIMS ANY WARRANTIES, EXPRESS, IMPLIED OR STATUTORY, NOT SPECIFICALLY SET FORTH ABOVE. WITHOUT LIMITING THE GENERALITY OF THE FOREGOING, THK EXPRESSLY DISCLAIMS ANY IMPLIED WARRANTIES OF MERCHANTABILITY, FITNESS FOR ANY PARTICULAR PURPOSE, INFRINGEMENT OR ANY REPRESENTATIONS OF FACT OR QUALITY NOT EXPRESSLY SET FORTH HEREIN.

LIMITATION OF LIABILITY AND REMEDIES: THK'S SOLE RESPONSIBILITY AND LIABILITY INCURRED AS A RESULT OF THE SALE AND/OR USE OF THE PRODUCT, AND THE PURCHASER'S EXCLUSIVE REMEDY AGAINST THK UNDER ANY WARRANTY SHALL BE LIMITED TO THE REPAIR OR REPLACEMENT, AT THK'S OPTION, OF PRODUCT COMPONENTS NOT CONFORMING TO THE WARRANTY. THE TOTAL LIABILITY OF THK SHALL IN NO EVENT EXCEED THE AMOUNT ACTUALLY PAID TO THK BY PURCHASER WITH RESPECT TO THE PRODUCT. THIS LIMITATION OF REMEDY IS INTENDED BY THE PARTIES TO SURVIVE EVEN IF THE REMEDY IS CLAIMED TO HAVE FAILED OF ITS ESSENTIAL PURPOSE. PURCHASER'S FULL AND COMPLETE PERFORMANCE OF ALL OBLIGATIONS OF PURCHASER RECITED IN THIS AGREEMENT IS A CONDITION PRECEDENT TO THK'S WARRANTY OBLIGATIONS AND LIABILITIES HEREIN.

PURCHASER'S DAMAGES AND LIMITATIONS: IN NO EVENT SHALL THK BE LIABLE TO PURCHASER, ITS ASSIGNS OR AGENTS, FOR ECONOMIC LOSS, INCIDENTAL OR CONSEQUENTIAL DAMAGES, IN CONTRACT OR IN TORT, INCLUDING BUT NOT LIMITED TO, ANY DAMAGES FOR LOST PROFITS, DOWN-TIME, LOST PRODUCTION, FAILURE TO MEET PURCHASER'S SALES CONTRACTS, OR DEFECTS IN PURCHASER'S MATERIALS OR WORKMANSHIP ARISING DIRECTLY OR INDIRECTLY FROM THE USE OF THE PRODUCT.

DISCLAIMER

This Catalog provides basic information relating to THK linear motion and related products. The Catalog, including all information, charts, formulas, factors, accuracy standards, tolerances and application recommendations contained herein, is only a starting point for the customer's selection of appropriate products, and may not apply in all intended applications. The Catalog is not a substitute for a proper application analysis conducted by an experienced, knowledgeable design engineer. Product selection should be based upon your specific application needs and conditions, which will vary greatly depending on many factors. No specific product application should be based solely on the information contained in this Catalog. All purchases of THK Products are subject to the limited warranty offered by THK Co., Ltd, for itself and on behalf of its related companies and subsidiaries. Customers should confirm independently that a contemplated application is safe, appropriate and effective.

"All trademarks used in this Catalog are registered trademarks in the Country of Japan. If there is any question as to the validity of such trademarks outside of Japan, an inquiry should be made in that particular country."

Technical Support Site

The THK Technical Support Site lets you access product information and technical support online. You will also find a search feature for locating desired products and a calculation feature for calculating service life. 2D-CAD and 3D-CAD data are also downloadable.

<http://www.thk.com/> or

Top page of the Global site

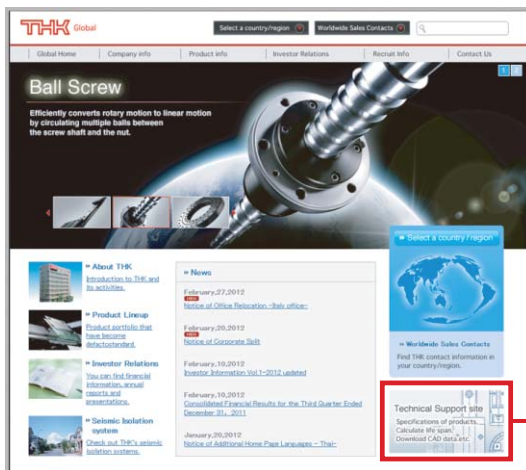

<http://www.thk.com/>

Technical Support Site

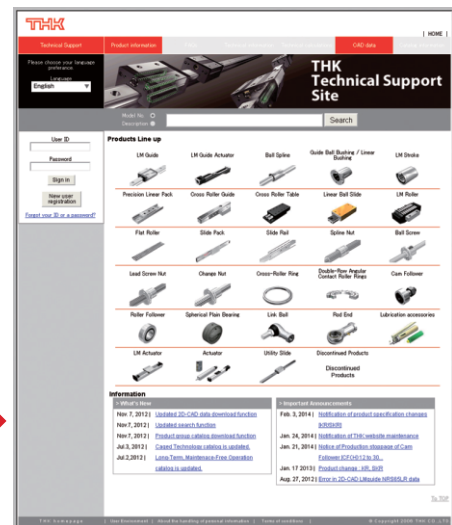

<https://tech.thk.com/>

Product Information

Search by model number or description. Also contains detailed product specifications according to model number.

Technical Information

Contains technical information, from application examples to research papers.
(* To use this service, you must log in first.)

Technical Calculation

Rated life (life time) can be calculated simply by entering model number, application criteria, etc.
(* To use this service, you must log in first.)

CAD Data

You can acquire 2D-CAD data (DXF files) on approximately 4,000 items, or 3D-CAD data according to specifications from rail lengths to installation of option items.
(* To use this service, you must log in first.)

Catalog Information

Order any of a variety of catalogs. You can also view in PDF format.
(* To use this service, you must log in first.)

FAQ

Contains frequently asked questions.

Linear Motion System DVD Catalog

Linear Motion System DVD Catalog is also available. Please contact THK, distributors or other purchasable contacts in your area for a request.



Please choose your preferred language.

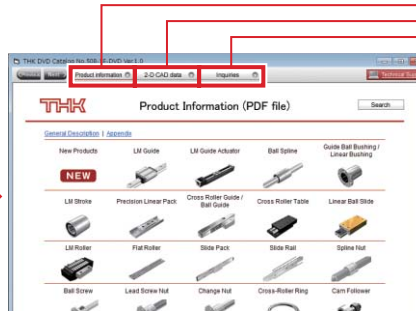

Displays product information.

Enables you to use 2-D CAD data (DXF files).

Enables you to use 3-D CAD data.

Product information (PDF file)

Contains catalog PDF data for new products and mechatronic products, in addition to the product information contained in the General Catalog.

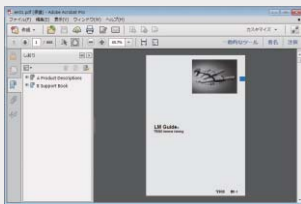

2-D CAD data (DXF file)

You can use 2-D CAD data (DXF files) for approximately 4,000 products.

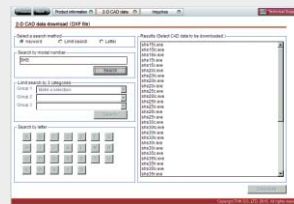

3-D CAD data generation program

This function enables you to use 3-D CAD data.

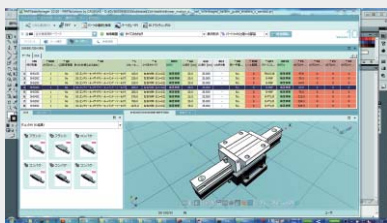

Selectable options and specifications

By combining product model numbers and options, you can generate 3-D CAD data tailored to your specifications.

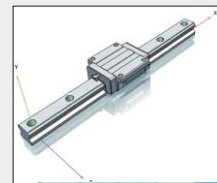

3-D CAD and 2-D CAD data

You can then quickly and easily import the generated 3-D CAD data into your 3-D CAD software. 2-D CAD data can also be generated with this program.

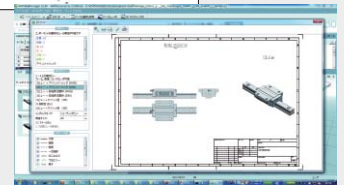

CAD type	Formats supported
3-D CAD	DXF 3D / IGES / SAT / STEP Solidworks 2013, 2014, 2015, Macro 3D
2-D CAD	DXF Version 2004-2015